



---

## CERTIFICATE OF APPROVAL

### No CF811

---

This is to certify that, in accordance with  
TS00 General Requirements for Certification of Fire Protection Products  
The undermentioned products of

# VETROTECH SAINT-GOBAIN INTERNATIONAL AG

Industriestr. 44, 3175, Flamatt, Switzerland  
Tel: +41 313368181 Fax: +41 313368119  
Website: [www.vetrotech.com](http://www.vetrotech.com)

Have been assessed against the requirements of the Technical Schedule(s)  
denoted below and are approved for use subject to the conditions  
appended hereto:

---

#### CERTIFIED PRODUCT

Contraflam Fire Resisting Glass

#### TECHNICAL SCHEDULE

TS 25 Fire Resistant Glass,  
Glazing Systems and Materials

Signed and sealed for and on behalf of Warringtonfire Testing and Certification Limited

Paul Duggan  
Certification Manager



Issued: 2<sup>nd</sup> July 2025  
Audit Test Frequency: Every 3 years  
Valid to: 1<sup>st</sup> July 2030





---

## CERTIFICATE No CF811

### Vetrotech Saint-Gobain International AG

---

1. This certification is provided to the client for their own purposes and we cannot opine on whether it will be accepted by Building Control authorities or any other third parties for any purpose.
2. This Certificate of Approval must be read in conjunction with CERTIFIRE Technical Schedule TS00-General Requirements for Certification of Fire Protection Products and TS25-Fire Resistant Glass, Glazing Systems and Materials.
3. This product is approved on the basis of:
  - i) Initial Type Testing.
  - ii) A design appraisal against TS25.
  - iii) Certification of Quality Management System to ISO 9001.
  - iv) Inspection and surveillance of factory production control.
  - v) Audit testing at a frequency defined in TS25.
4. This Certificate of Approval relates to the fire resistance of Contraflam glass when used in the following applications, as defined in BS 476: Part 22: 1987, and subject to the undermentioned conditions.

#### **General Requirements (applying to all applications):**

- All maximum height, width and area dimensions relate to the glass pane size.
- There is no restriction to the direction of exposure for the glass i.e. the glass is symmetrical. Orientation may, however, be restricted by the requirements of a non-symmetrical framing system or certain double glazed unit specifications.
- The edge cover to each pane of Contraflam Glass shall be minimum 15 mm, unless stated otherwise, as detailed for each specific application on the following pages.
- The Contraflam glass family is approved in a nominal thickness from 11 to 80 mm (depending on application).
- Adhesive/adherent polyester/polyethylene terephthalate (PET) or polyvinyl Chloride (PVC) films may be applied to the free vision area of a glazed element. They may have a thickness between 25 and 250 µm.
- Glazing bars, flashings, trims (timber, steel, alu) etc may be applied to the glass surface using 3M '4941' VHB double sided tape. The glazing bars must not be fixed to the perimeter beads.



---

## CERTIFICATE No CF811

### Vetrotech Saint-Gobain International AG

---

#### Glazed Screen Specific Requirements:

- Where the glass is installed in an aluminium, timber or steel framed screen, the orientation of the screen shall be no more than  $\pm 10^\circ$  from the vertical.
- For timber constructions; where beading is depicted (on the relevant page of this certificate) on both faces of the glass – this must be strictly adhered to. i.e. there shall be no substitution of one of the beads for a rebated timber profile. Where a rebated timber profile is shown, however, this may be substituted for a beaded profile. Furthermore; where square beading is depicted a chamfered bead may be used provided the minimum dimensions are still met (including height and edge cover requirements). Where pins are depicted, screws may be used instead. The opposite is not applicable.
- Timber screens may also include a faceted design where the glass to be used is fully insulating in nature (i.e. the insulation and integrity rating are the same). This angle will be incorporated within the dimensions of the main inter-glass timber section (the member into which the pins/screws, holding the beading, penetrate). The minimum timber dimensions, already stated on the relevant page, shall be observed in order to accomplish the faceted design i.e. any individual dimension of the timber may be increased, to incorporate the angle, but none shall be decreased. All other requirements of the framing system, on the relevant page concerned, shall be met. The resultant angle shall not be less than  $150^\circ$  (i.e. an internal angle of  $30^\circ$  from the plain of the surface).
- As indicated steel profiled screen framing systems shall have suitable test evidence (applicable systems from Jansen or Forster for example), or be CERTIFIRE approved for the inclusion of apertures of the proposed dimensions. Aluminium systems are limited to the tested framing system (as referenced on the relevant page of this certificate).
- Where insulation performance is required for steel or aluminium screen applications, care must be taken to ensure the steel or aluminium frame has test data proving its insulation performance for the required duration using insulating glasses.
- Glazing pocket (aperture) liner, Mann McGowan Pyrostrip 300 SA can be substituted for one of the following liners:
  - Kuhn Flexpan 200
  - Odice Flexilodice

Glazing pocket (aperture) liner tape shall be  $\geq$  the thickness of the glass.

- Mann McGowan Pyrotape CF tape can be substituted for one of the following ceramic fibre tapes:
  - Kuhn Kerafix 2000
  - Hodgson Sealants Firetape Ceramic
  - Fiberfrax Ceramic Tape
  - Ceramic fibre glazing tape may be replaced with any CERTIFIRE approved glazing gasket system.

## CERTIFICATE No CF811

### Vetrotech Saint-Gobain International AG

- For glazed screen applications, the following glass types may incorporate a minimum 9 mm STADIP 44.2 laminated glass layer in substitution for the 5 mm SECURIT glass layer, used on one face of the composition of the Contraflam glass. Furthermore; the outer face of this laminated glass may, optionally, be a patterned glass. The above is subject to restrictions as defined on the applicable page of this certificate, details are given on the applicable pages:

Contraflam Door Lite	Contraflam Lite 30	Contraflam Lite 60
Contraflam Lite 90	Contraflam Lite 120	Contraflam 30
Contraflam 30-2	Contraflam 60-3	Contraflam 90-4
Contraflam 120-5	Contraflam 120-6	

- It is also acceptable to include the Contraflam glasses in shaped apertures, i.e. circles, ovals, arches, quadrants, etc (examples detailed below) within timber, steel and aluminium screens (subject to limitations in the framing systems). For rectilinear apertures angles between adjoining perimeter beads should not be less than 45°. Where shaped apertures are included in timber framed screens, only finger jointed glazing beads are acceptable. Maximum linear dimensions or areas as approved should not be exceeded.

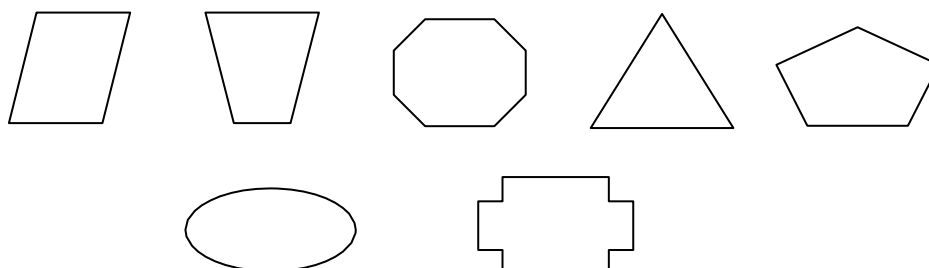

- Where Insulating Glass Units (Climaplus) are approved the non-fire, counter, pane may be a float glass, a toughened glass, patterned glass or a laminated glass (including laminated patterned glass) unless stated otherwise on the relevant page.

The fire resistant pane of an IGU construction can be used as a single glazed pane in any previously fire tested or CERTIFIRE approved system.

Subject to product availability, any single pane, fire resistant, glass listed in this certificate may be used as the fire resistant pane of a fire rated IGU. The IGU may be glazed in to any previously fire tested or CERTIFIRE approved system but is limited in size to those of the listed fire rated glass.

Contraflam Climaplus units may incorporate internal blind systems or Georgian bars where required.

The screens shall be no greater than 4000 mm high unless suitable tie backs and/or fire protected structural supports are provided, unless glass height is  $\geq 4000$  mm, or unless there is suitable test evidence proving otherwise.



# CERTIFICATE No CF811

## Vetrotech Saint-Gobain International AG

### Structure (Butt Jointed) Specific Requirements:

- The orientation of the screen shall be no more than  $\pm 10^\circ$  from the vertical.
- For Structure (Butt Jointed) applications, the following glass types may incorporate a minimum 9 mm STADIP 44.2 laminated glass layer in substitution for the 5 mm SECURIT glass layer, used on one face of the composition of the Contraflam glass. Furthermore; the outer face of this laminated glass may, optionally, be a patterned glass. The above is subject to restrictions as defined on the applicable page of this certificate, details are given on the applicable pages:

Contraflam Structure Lite 30	Contraflam Structure 30	Contraflam Structure 60
Contraflam Structure 90	Contraflam Structure 120	Contraflam Structure 30 Corner
Contraflam Structure 60 Corner		

### Doorset Specific Requirements:

- As indicated steel profiled screen framing systems shall have suitable test evidence (applicable systems from Jansen or Forster for example), or be CERTIFIRE approved for the inclusion of apertures of the proposed dimensions. Aluminium systems are limited to the tested framing system (as referenced on the relevant page of this certificate).
- Where insulation performance is required for steel or aluminium door applications, care must be taken to ensure the steel or aluminium frame has test data proving its insulation performance for the required duration using insulating glasses.
- Glazing pocket (aperture) liner, Mann McGowan Pyrostrip 300 SA can be substituted for one of the following liners:
  - Kuhn Flexpan 200
  - Odice Flexilodice
- Mann McGowan Pyrotape CF tape can be substituted for one of the following ceramic fibre tapes:
  - Kuhn Kerafix 2000
  - Hodgson Sealants Firetape Ceramic
- For door applications, the following glass types may incorporate a minimum 9 mm STADIP 44.2 laminated glass layer in substitution for the 5 mm SECURIT glass layer, used on one face of the composition of the Contraflam glass. Furthermore; the outer face of this laminated glass may, optionally, be a patterned glass. The above is subject to restrictions as defined on the applicable page of this certificate, details are given on the applicable pages:

Contraflam Lite 30	Contraflam Lite 60	Contraflam Lite 90
Contraflam Lite 120	Contraflam 30	Contraflam 30-2
Contraflam 60-3	Contraflam 90-4	Contraflam 120-6

- It is also acceptable to include the Contraflam glasses in shaped apertures, i.e. circles, ovals, arches, quadrants, etc (examples detailed below) within timber and steel doorsets (subject to limitations

Page 5 of 194 Signed  
E014243-3,E014243-4

Issued: 2<sup>nd</sup> July 2025  
Valid to: 1<sup>st</sup> July 2030

EWC-QU-FT-733 (Issue 2)

---

## CERTIFICATE No CF811

### Vetrotech Saint-Gobain International AG

---

in the glazing system). For rectilinear apertures angles between adjoining perimeter beads should not be less than 45°. Where shaped apertures are included in timber doorsets, only finger jointed glazing beads are acceptable. Maximum linear dimensions or areas as approved should not be exceeded.

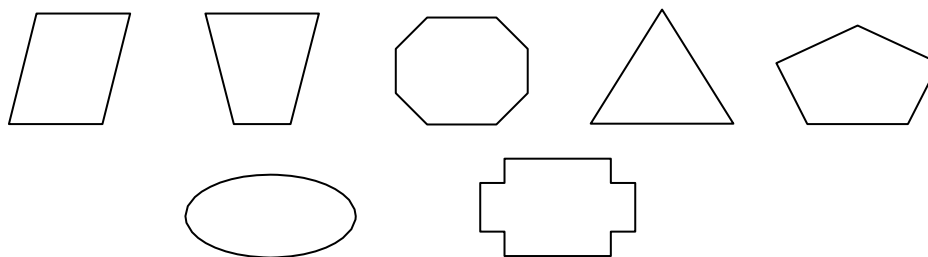

- Where Insulating Glass Units (Climaplus) are approved; the non-fire, counter pane may be a float glass, a toughened glass, patterned glass or a laminated glass (including laminated patterned glass) unless stated otherwise on the relevant page.

The fire resistant pane of an IGU construction can be used as a single glazed pane in any previously fire tested or CERTIFIRE approved system.

Subject to product availability, any single pane, fire resistant, glass listed in this certificate may be used as the fire resistant pane of a fire rated IGU. The IGU may be glazed in to any previously fire tested or CERTIFIRE approved system but is limited in size to those of the listed fire rated glass.

Contraflam Climaplus units may incorporate internal blind systems or Georgian bars where required.



**CERTIFICATE No CF811**  
**Vetrotech Saint-Gobain International AG**

Glass	Application	Integrity – (mins)	Insulation – (mins)	Page No.
Contraflam Door Lite	Steel Screens	120	15	13
	Timber Screens	30	0	14
Contraflam Door Lite Climaplust	Steel Screens	30	0	15
	Steel Screens	60	15	16
	Steel Screens	90	15	17
	Steel Screens	120	15	18
	Steel Screens (Climalit)	120	15	19
	Timber Screens	30	0	20
	Contraflam Lite 30	Steel Screens	30	0
Timber Screens		30	0	22
Aluminium Screens		30	0	23
Aluminium Screens		30	0	24
Aluminium Screens		30	0	25
Contraflam Lite 30 Climaplust	Steel Screens	30	0	26
	Timber Screens	30	0	27
	Timber Screens	30	15	28
	Aluminium Screens	30	0	29
	Aluminium Screens	30	15	30
Contraflam Lite 60	Steel Screens	60	0	31
	Steel Screens	60	15	32
	Timber Screens	60	15	33
Contraflam Lite 60 Climaplust	Steel Screens	60	0	34
	Steel Screens	60	15	35
	Timber Screens	60	0	36
	Timber Screens	60	15	37
	Aluminium Screens	60	15	38
Contraflam Lite 90	Steel Screens	90	0	39
	Timber Screens	90	0	40
Contraflam Lite 90 Climaplust	Steel Screens	90	0	41
	Steel Screens	90	15	42
	Timber Screens	90	0	43
Contraflam Lite 120	Steel Screens	120	0	44

Page 7 of 194 Signed  
E014243-3,E014243-4

Issued: 2<sup>nd</sup> July 2025  
Valid to: 1<sup>st</sup> July 2030

EWC-QU-FT-733 (Issue 2)



**CERTIFICATE No CF811**  
**Vetrotech Saint-Gobain International AG**

Contraflam Lite 120 Climaplus	Steel Screens	120	0	45
	Steel Screens (Climalit)	120	0	46
Contraflam 30	Steel Screens	30	30	47
	Steel Screens	60	30	48
	Steel Screens	90	30	49
	Steel Screens	120	30	50
	Timber Screens	30	30	51-52
	Timber Screens	30	30	53
	Aluminium Screens	30	30	54
	Aluminium Screens	30	30	55
	Aluminium Screens	30	30	56
	Aluminium Screens	30	30	57
	Aluminium Screens	30	30	58
	Aluminium Screens	30	30	59
Contraflam 30 Climaplus	Steel Screens	30	30	60
	Steel Screens	60	30	61
	Timber Screens	30	30	62-63
	Timber Screens	30	30	64
	Aluminium Screens	30	30	65
	Aluminium Screens	30	30	66
	Aluminium Screens	30	30	67
	Aluminium Screens	30	30	68
Contraflam 30 Contour	Steel Screens	120	30	69
	Timber Screens	30	30	70
Contraflam 30-2	Steel Screens	30	30	71
Contraflam 30-2 Climaplus	Steel Screens	30	30	72
Contraflam 30-2 Climatop	Steel Screens	30	30	73
Contraflam 60-3	Steel Screens	60	60	74
	Timber Screens	60	60	75
	Aluminium Screens	60	60	76
	Aluminium Screens	60	60	77
	Aluminium Screens	60	60	78
	Aluminium Screens	60	60	79
	Aluminium Screens	60	60	80
	Aluminium Screens	60	60	81



**CERTIFICATE No CF811**  
**Vetrotech Saint-Gobain International AG**

Contraflam 60-3 Climaplus	Steel Screens	60	60	82
	Timber Screens	60	60	83
	Aluminium Screens	60	60	84
	Aluminium Screens	60	60	85
	Aluminium Screens	60	60	86
	Aluminium Screens	60	60	87
	Aluminium Screens	60	60	88
	Aluminium Screens	60	60	89
Contraflam 90-4	Steel Screens	90	90	90
Contraflam 90-4 Climaplus	Steel Screens	90	90	91
Contraflam 120-5	Steel Screens	120	120	92
Contraflam 120-5 Climaplus	Steel Screens	120	120	93
Contraflam 120-6	Steel Screens	120	120	94
Contraflam 120-6 Climaplus	Steel Screens	120	120	95
Contraflam Structure Lite30 (20 mm)	Steel Screens	30	0	96
	Timber Screens	30	0	97
Contraflam Structure Lite 30	Installation Instructions	-	-	98
Contraflam Structure Lite 60 (20 mm)	Steel Screens	60	0	99
	Timber Screens	60	0	100
Contraflam Structure Lite 60	Installation Instructions	-	-	101
Contraflam Structure 30 (23 mm)	Steel Screens	30	30	102
	Timber Screens	30	30	103
	Aluminium Screens	30	30	104
Contraflam Structure 30 (25 mm)	Steel Screens	60	30	105
	Timber Screens	60	30	106
Contraflam Structure 30 (28 mm)	Steel Screens	30	30	107
	Timber Screens	30	30	108
	Aluminium Screens	30	30	109
Contraflam Structure 30 (30 mm)	Steel Screens	30	30	110
	Timber Screens	30	30	111
	Aluminium Screens	30	30	112
Contraflam Structure 30	Installation Instructions	-	-	113-114
Contraflam Structure 30 (23 mm) Corner	Steel Screens	30	30	115
	Timber Screens	30	30	116
	Aluminium Screens	30	30	117



## CERTIFICATE No CF811

### Vetrotech Saint-Gobain International AG

Contraflam Structure 30 (28 mm) Corner	Steel Screens	30	30	118
	Timber Screens	30	30	119
	Aluminium Screens	30	30	120
Contraflam Structure 30 Corner	Installation Instructions	-	-	121-122
Contraflam Structure 30 IGU	Steel Screens	30	30	123
	Timber Screens	30	30	124
	Aluminium Screens	30	30	125
Contraflam Structure 30 IGU	Installation Instructions	-	-	126-127
Contraflam Structure 30 Corner IGU	Steel Screens	30	30	128
Contraflam Structure 30 Corner IGU	Installation Instructions	-	-	129
Contraflam Structure 30 Point (23 mm)	Point Wise mounting	60	30	130-132
Contraflam Structure 60 (31 mm)	Steel Screens	60	60	133
	Timber Screens	60	60	134
	Aluminium Screens	60	60	135
Contraflam Structure 60 (33 mm)	Steel Screens	60	60	136
	Timber Screens	60	60	137
	Aluminium Screens	60	60	138
Contraflam Structure 60 (41 mm)	Steel Screens	60	60	139
	Timber Screens	60	60	140
	Aluminium Screens	60	60	141
Contraflam Structure 60	Installation Instructions	-	-	142
Contraflam Structure 60 (31 mm) Corner	Steel Screens	60	60	143
Contraflam Structure 60 (33 mm) Corner	Steel Screens	60	60	144
Contraflam Structure 60	Installation Instructions	-	-	145
Contraflam Structure 60 IGU	Steel Screens	60	60	146
	Timber Screens	60	60	147
	Aluminium Screens	60	60	148
Contraflam Structure 60 IGU	Installation Instructions	-	-	149-150
Contraflam Structure 90	Steel Screens	90	90	151-152
Contraflam Structure 90	Installation Instructions	-	-	153
Contraflam Structure 120	Steel Screens	120	120	154
Contraflam Structure 120	Installation Instructions	-	-	155



## CERTIFICATE No CF811

### Vetrotech Saint-Gobain International AG

Contraflam Structure 120-5	Steel Screens	120	120	156
Contraflam Structure 120-5	Installation Instructions	-	-	157
Contraflam Door Lite (11 mm thick)	Steel Doors	90	15	158
	Steel Doors	120	15	159
	Steel Doors	180	0	160
	Timber Doors	30	15	161
	Timber Doors	90	15	162
	Timber Doors	90	15	163
Contraflam Lite 30 (13 mm minimum)	Steel Doors	30	0	164
	Timber Doors	30	15	165
	Aluminium Doors	30	0	166
Contraflam Lite 30 Climaplus (13 mm minimum)	Steel Doors	30	15	167
	Timber Doors	30	15	168
Contraflam Lite 60 (14 mm minimum)	Steel Doors	60	0	169
	Timber Doors	60	0	170
Contraflam Lite 90 (14 mm)	Steel Doors	90	0	171
Contraflam Lite 120 (14 mm)	Steel Doors	120	0	172
Contraflam 30 (16 mm minimum)	Steel Doors	30	30	173
	Steel Doors	60	30	174
	Steel Doors	90	30	175
	Steel Doors	120	30	176
	Timber Doors	30	30	177
	Aluminium Doors	30	30	178
	Aluminium Doors	30	30	179
	Aluminium Doors	30	30	180
Contraflam 30 Climaplus (16 mm minimum)	Steel Doors	30	30	181
	Steel Doors	90	30	182
	Steel Doors	120	30	183
Contraflam 30-2 (20 mm minimum)	Steel Doors	30	30	184
	Timber Doors	30	30	185
	Aluminium Doors	30	30	186
Contraflam 60-3 (27 mm minimum)	Steel Doors	60	60	187
	Timber Doors	60	60	188
	Aluminium Doors	60	60	189



**CERTIFICATE No CF811**  
**Vetrotech Saint-Gobain International AG**

Contraflam 60-3 Climaplast (27 mm minimum)	Steel Doors	60	60	190
Contraflam 90-4 (40 mm minimum)	Steel Doors	90	90	191
	Aluminium Doors	90	90	192
	Aluminium Doors	90	90	193
Contraflam 120-6 (62 mm)	Steel Doors	120	120	194

## CERTIFICATE No CF811

### Vetrotech Saint-Gobain International AG

#### Contraflam Door Lite Glass in steel screens for periods of 120 minutes integrity and 15 minutes insulation

The glass shall be installed into a previously tested or CERTIFIRE approved framing system (which is covered appropriately by test or assessment evidence) using pressure plate glazing, screw-fixed or clip-on retaining beads, see examples below. The glass shall be glazed into the screen as described in the table below and set on non-combustible setting blocks to determine the correct edge cover.

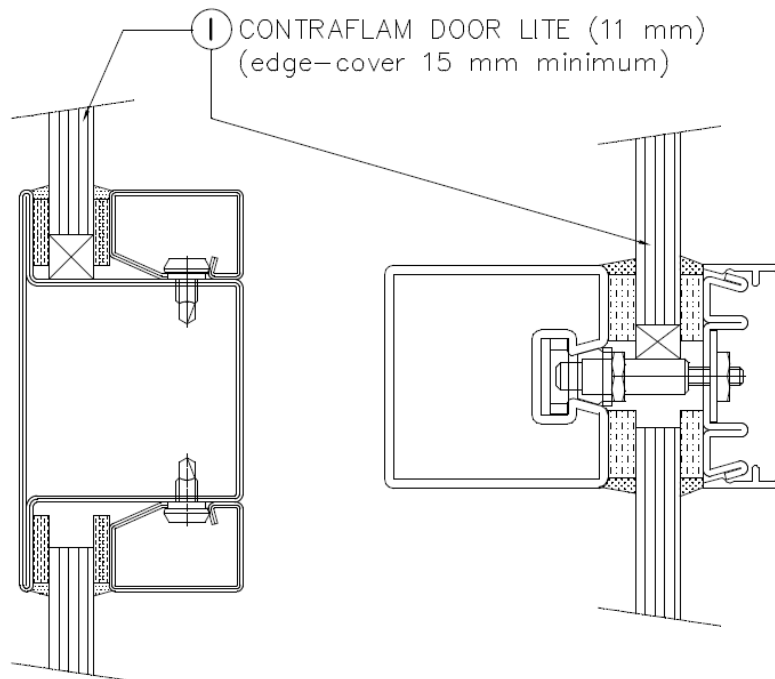

Max. Width (mm)	Max. Width (mm)	Max. Area (m <sup>2</sup> )
1100 (at 2200 high)	1100 (at 2200 high)	2.42

## CERTIFICATE No CF811

### Vetrotech Saint-Gobain International AG

#### Contraflam Door Lite Glass in timber framed screens for periods of 30 minutes integrity

The glass shall be glazed utilising the following basic specification:

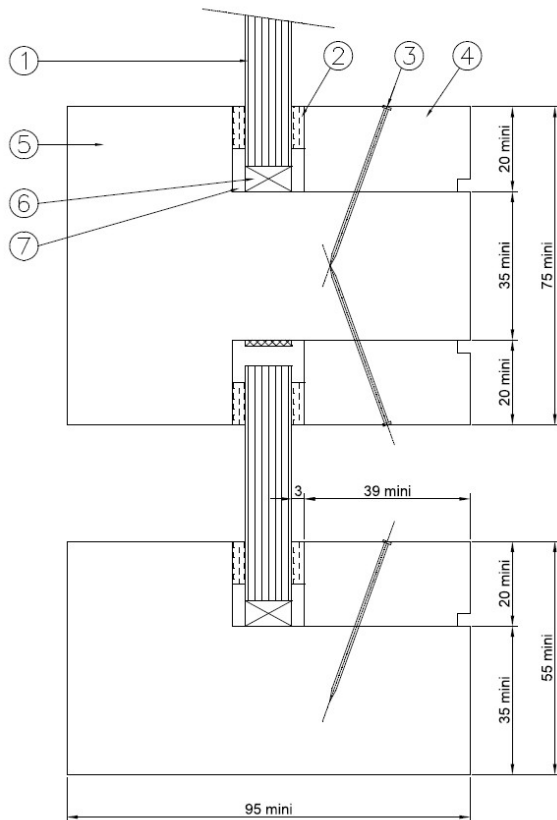

- ① CONTRAFLAM DOOR LITE (11 mm thick) (edge-cover 15 mm)
- ② Mann McGowan Pyroglaze 30 glazing seal 3 x 10 mm
- ③ Ø 1.8 x 40 mm long steel pins at 150 mm centres
- ④ Minimum 20 x 39 mm (h x w) timber glazing beads minimum density 510 kg/m<sup>3</sup>
- ⑤ Minimum 95 x 55 mm outer timber framing section & 95 x 75 mm intermediate timber framing section. Minimum density 510 kg/m<sup>3</sup>
- ⑥ Non-combustible / hardwood setting blocks glass thickness x 5 x 80 mm (w x h x d) (2 pieces per glass, on the bottom only)
- ⑦ Glazing pocket liner, Mann McGowan Pyroglaze 300 SA, section 2 mm x glass thickness (mm)

Max. Width (mm)	Max. Height (mm)	Max. Area (m <sup>2</sup> )
1100 (at 2200 high)	2200 (at 1100 wide)	2.42

## CERTIFICATE No CF811

### Vetrotech Saint-Gobain International AG

#### Contraflam Door Lite Climaplus Glass in steel screens for periods of 30 minutes integrity

The glass shall be installed into a previously tested or CERTIFIRE approved framing system (which is covered appropriately by test or assessment evidence) using pressure plate glazing, screw-fixed or clip-on retaining beads, see examples below. The glass shall be glazed into the screen as described in the table below and set on non-combustible setting blocks to determine the correct edge cover.

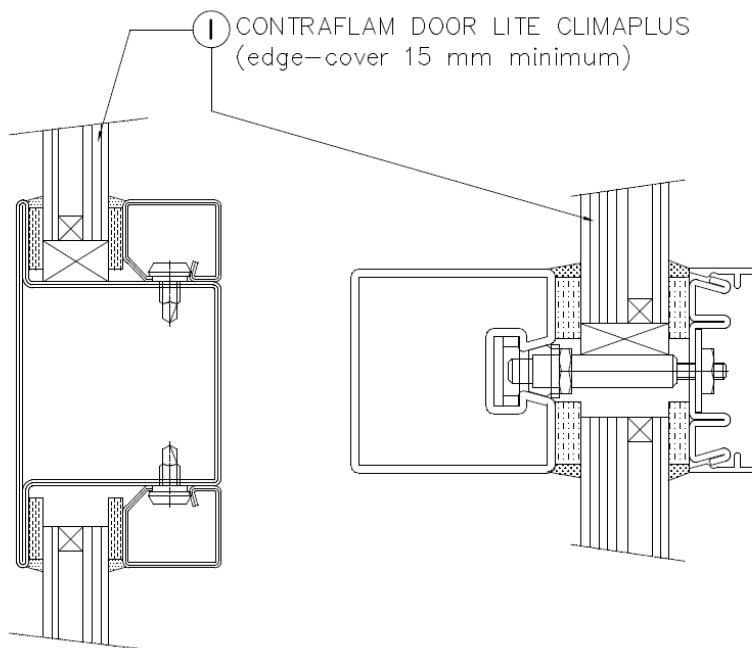

Max. Width (mm)	Max. Height (mm)	Max. Area (m <sup>2</sup> )
1000 (at 2000 high)	2000 (at 1000 wide)	2.0

## CERTIFICATE No CF811

### Vetrotech Saint-Gobain International AG

#### Contraflam Door Lite Climaplus Glass in steel screens for periods of 60 minutes integrity and 15 minutes insulation

The glass shall be installed into a previously tested or CERTIFIRE approved framing system (which is covered appropriately by test or assessment evidence) using pressure plate glazing, screw-fixed or clip-on retaining beads, see examples below. The glass shall be glazed into the screen as described in the table below and set on non-combustible setting blocks to determine the correct edge cover.

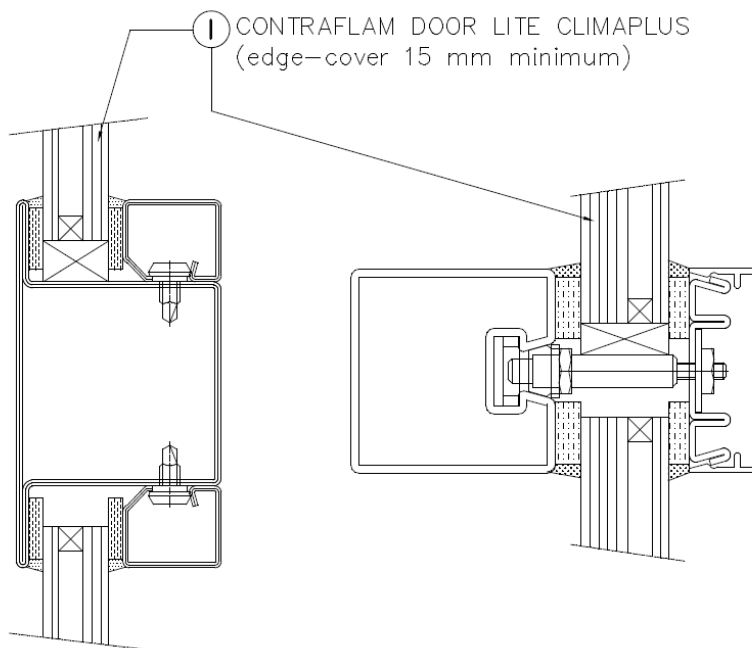

Max. Width (mm)	Max. Height (mm)	Max. Area (m <sup>2</sup> )
1000 (at 2000 high)	2000 (at 1000 wide)	2.0

## CERTIFICATE No CF811

### Vetrotech Saint-Gobain International AG

#### Contraflam Door Lite Climaplus Glass in steel screens for periods of 90 minutes integrity and 15 minutes insulation

The glass shall be installed into a previously tested or CERTIFIRE approved framing system (which is covered appropriately by test or assessment evidence) using pressure plate glazing, screw-fixed or clip-on retaining beads, see examples below. The glass shall be glazed into the screen as described in the table below and set on non-combustible setting blocks to determine the correct edge cover.

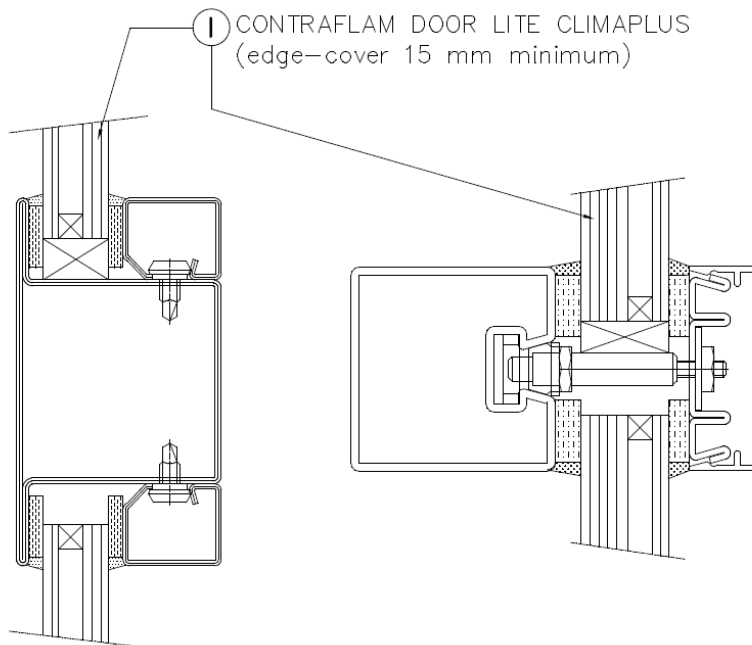

Max. Width (mm)	Max. Height (mm)	Max. Area (m <sup>2</sup> )
1000 (at 2000 high)	2000 (at 1000 wide)	2.0

**Note: If applicable, a STADIP laminated counterpane or STADIP laminated glass used in the composition of the Contraflam unit is allowable, but on the fire side only.**

## CERTIFICATE No CF811

### Vetrotech Saint-Gobain International AG

#### Contraflam Door Lite Climaplus (low-e or solar controlled coating) Glass in steel screens for periods of 120 minutes integrity and 15 minutes insulation

The glass shall be installed into a previously tested or CERTIFIRE approved framing system (which is covered appropriately by test or assessment evidence) using pressure plate glazing, screw-fixed or clip-on retaining beads, see examples below. The glass shall be glazed into the screen as described in the table below and set on non-combustible setting blocks to determine the correct edge cover.

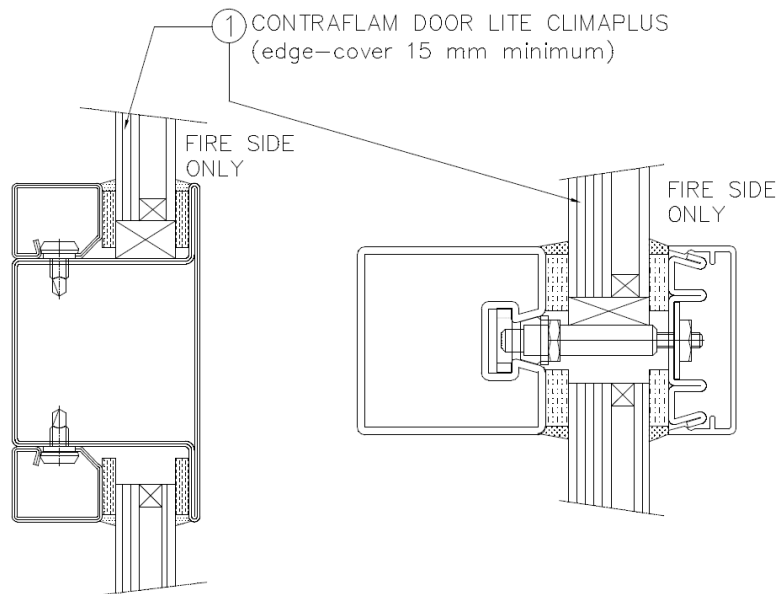

Max. Width (mm)	Max. Height (mm)	Max. Area (m <sup>2</sup> )
1000 (at 2000 high)	2000 (at 1000 wide)	2.0

**Note:** Where the counterpane of the IGU has a low-e or solar controlled coating, it shall be limited to use on the exposed face only. i.e. fire side to counter pane side only.

**Note:** If applicable, a STADIP laminated counterpane or STADIP laminated glass used in the composition of the Contraflam unit is allowable, but on the fire side only.

## CERTIFICATE No CF811

### Vetrotech Saint-Gobain International AG

#### Contraflam Door Lite Climalit (no low-e or solar controlled coating) Glass in steel screens for periods of 120 minutes integrity and 15 minutes insulation

The glass shall be installed into a previously tested or CERTIFIRE approved framing system (which is covered appropriately by test or assessment evidence) using pressure plate glazing, screw-fixed or clip-on retaining beads, see examples below. The glass shall be glazed into the screen as described in the table below and set on non-combustible setting blocks to determine the correct edge cover.

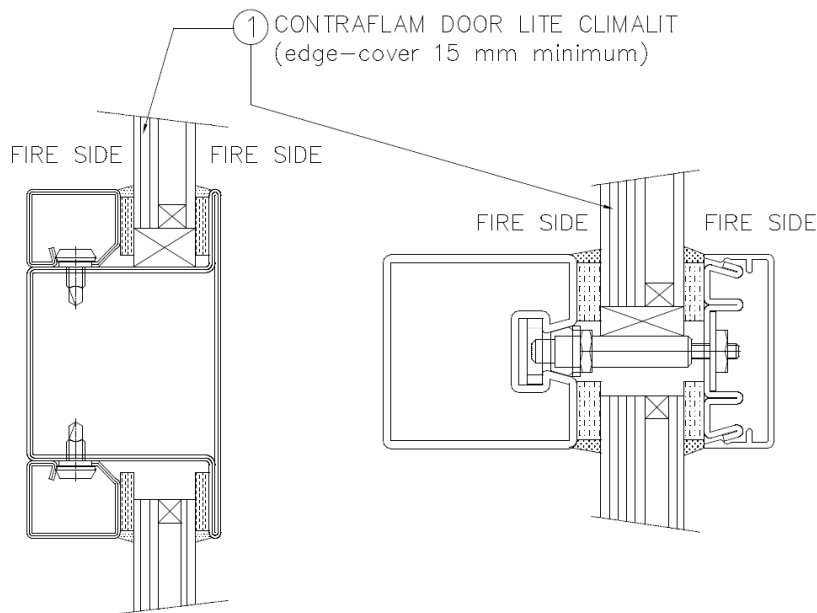

Max. Width (mm)	Max. Height (mm)	Max. Area (m <sup>2</sup> )
1000 (at 2000 high)	2000 (at 1000 wide)	2.0

**Note:** Where the counterpane of the IGU does not incorporate a low-e or solar controlled coating, it shall be limited to internal (building) use only.

**Note:** This construction may be oriented in either direction. i.e. fire side to both sides.

**Note:** If applicable, a STADIP laminated counterpane or STADIP laminated glass used in the composition of the Contraflam unit is allowable, but on the fire side only.

## CERTIFICATE No CF811

### Vetrotech Saint-Gobain International AG

#### Contraflam Door Lite Climaplus Glass in timber framed screens for periods of 30 minutes integrity

The glass shall be glazed utilising the following basic specification:

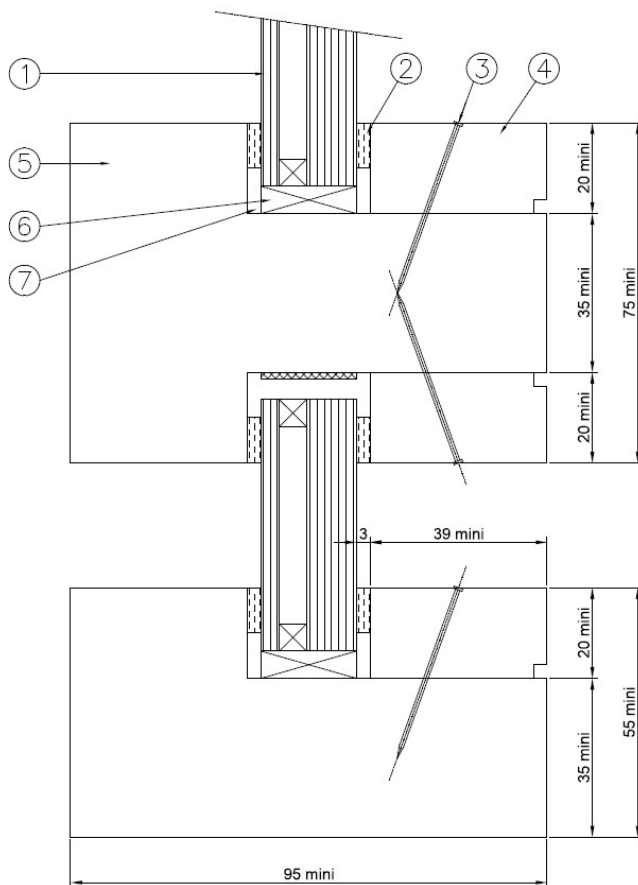

- ① CONTRAFLAM DOOR LITE CLIMAPLUS (edge-cover 15 mm)
- ② Mann McGowan Pyroglaze 30 glazing seal 3 x 10 mm
- ③ Ø 1.8 x 40 mm long steel pins at 150 mm centres
- ④ Minimum 20 x 39 mm (h x w) timber glazing beads minimum density 510 kg/m<sup>3</sup>
- ⑤ Minimum 95 x 55 mm outer timber framing section & 95 x 75 mm intermediate timber framing section. Minimum density 510 kg/m<sup>3</sup>
- ⑥ Non-combustible / hardwood setting blocks glass thickness x 5 x 80 mm (w x h x d) (2 pieces per glass, on the bottom only)
- ⑦ Glazing pocket liner, Mann McGowan Pyroglaze 300 SA, section 2 mm x glass thickness (mm)

**Table 8 – Maximum Permitted Glass Dimensions**

Max. Width (mm)	Max. Height (mm)	Max. Area (m <sup>2</sup> )
1000 (at 2000 high)	2000 (at 1000 wide)	2.0

## CERTIFICATE No CF811

### Vetrotech Saint-Gobain International AG

#### Contraflam Lite 30 Glass in steel framed screens for periods of 30 minutes integrity

The glass shall be installed into a previously tested or CERTIFIRE approved framing system (which is covered appropriately by test or assessment evidence) using pressure plate glazing, screw-fixed or clip-on retaining beads, see examples below. The glass shall be glazed into the screen as described in the table below and set on non-combustible setting blocks to determine the correct edge cover.

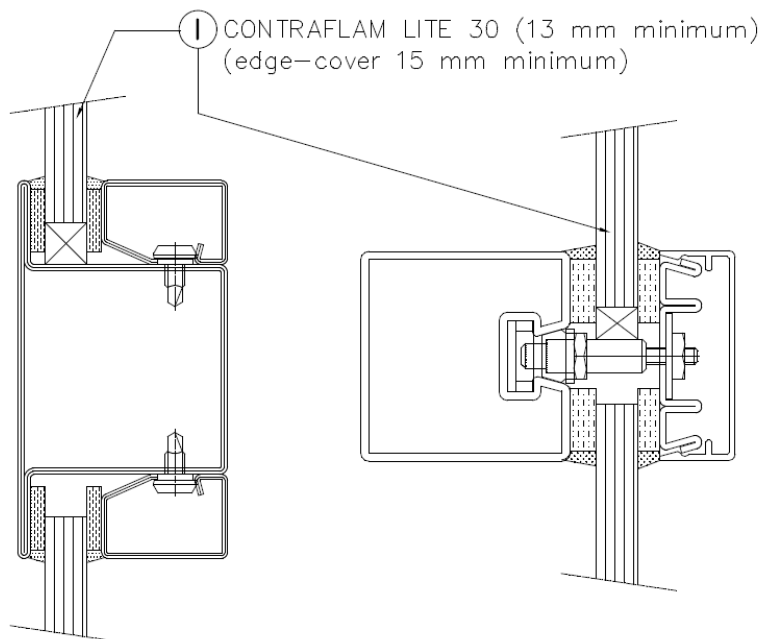

Max. Width (mm)	Max. Height (mm)	Max. Area (m <sup>2</sup> )
2300 (at 3800 high)	3800 (at 2300 wide)	8.74

## CERTIFICATE No CF811

### Vetrotech Saint-Gobain International AG

#### Contraflam Lite 30 Glass in timber framed screens for periods of 30 minutes integrity

The glass shall be glazed utilising the following basic specification:

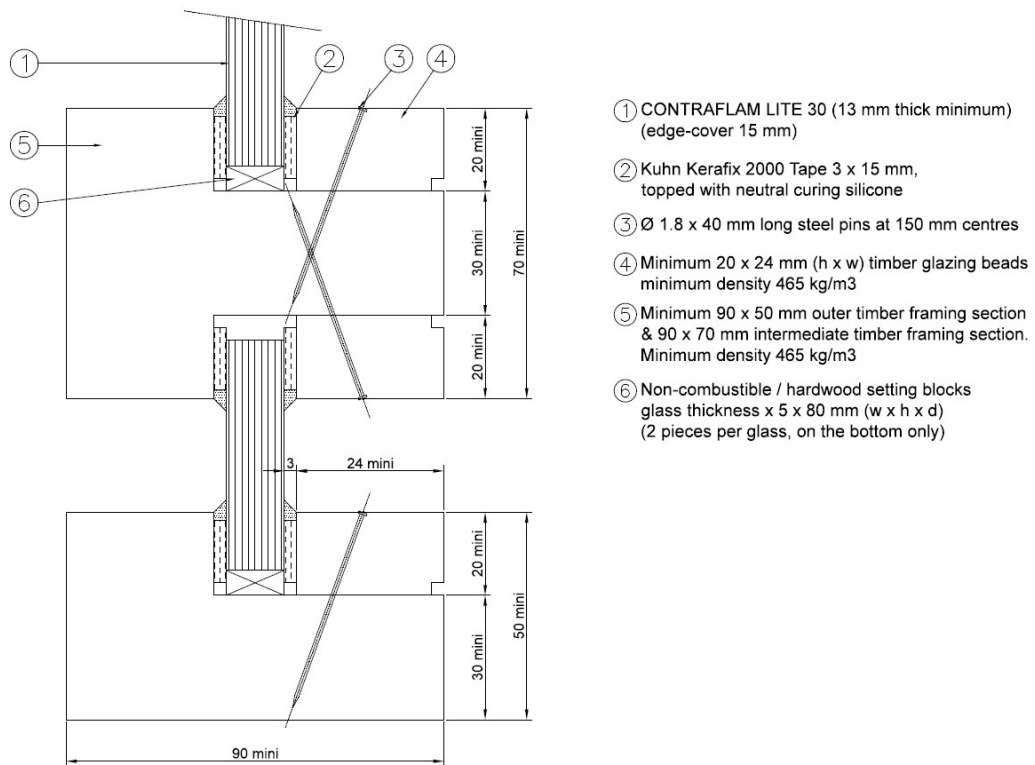

- ① CONTRAFLAM LITE 30 (13 mm thick minimum) (edge-cover 15 mm)
- ② Kuhn Kerafix 2000 Tape 3 x 15 mm, topped with neutral curing silicone
- ③ Ø 1.8 x 40 mm long steel pins at 150 mm centres
- ④ Minimum 20 x 24 mm (h x w) timber glazing beads minimum density 465 kg/m<sup>3</sup>
- ⑤ Minimum 90 x 50 mm outer timber framing section & 90 x 70 mm intermediate timber framing section. Minimum density 465 kg/m<sup>3</sup>
- ⑥ Non-combustible / hardwood setting blocks glass thickness x 5 x 80 mm (w x h x d) (2 pieces per glass, on the bottom only)

Max. Width (mm)	Max. Height (mm)	Max. Area (m <sup>2</sup> )
1392 (at 2992 high)	2992 (at 1392 wide)	4.17
1680 (at 2500 high)	3000 (at 1400 wide)	4.23
2400 (at 1400 high)	1680 (at 2000 wide)	3.38

## CERTIFICATE No CF811

### Vetrotech Saint-Gobain International AG

#### Contraflam Lite 30 Glass in Aluprof MB-78EI aluminium framed screens for periods of 30 minutes integrity

The glass shall be installed into the Aluprof MB-78EI aluminium framing system (which is covered appropriately by test or assessment evidence).

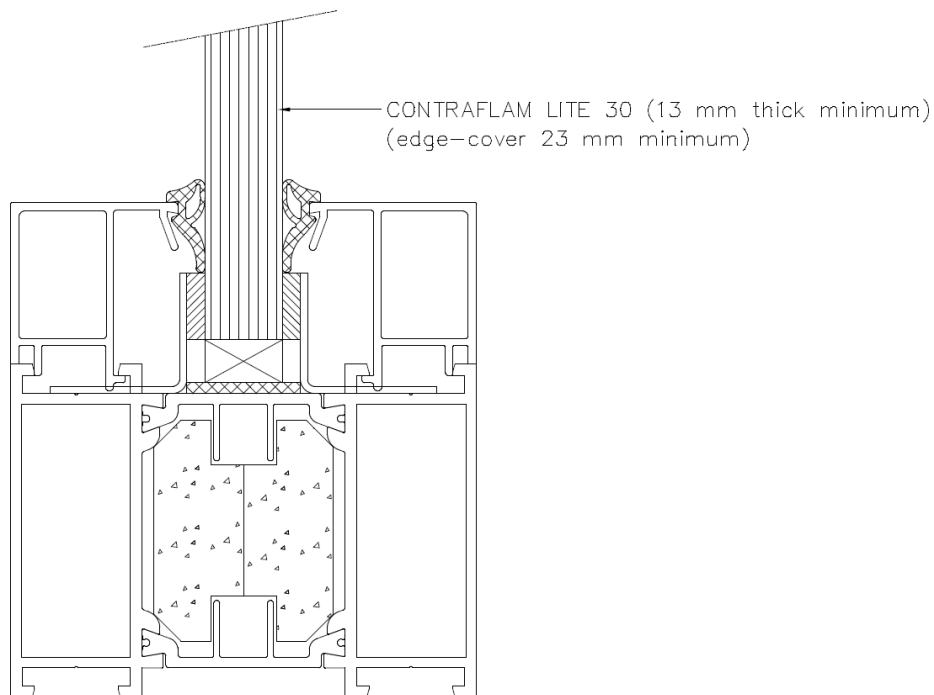

Table 11 – Maximum Permitted Glass Dimensions		
Max. Width (mm)	Max. Height (mm)	Max. Area (m2)
1749 (at 2008 high)	2329 (at 1508 wide)	3.51
1345 (at 2249 high)	2608 (at 1160 wide)	3.02

## CERTIFICATE No CF811

### Vetrotech Saint-Gobain International AG

#### Contraflam Lite 30 Glass in Reynaers CS77-FP aluminium framed screens for periods of 30 minutes integrity

The glass shall be installed into the Reynaers CS77-FP aluminium framing system (which is covered appropriately by test or assessment evidence).

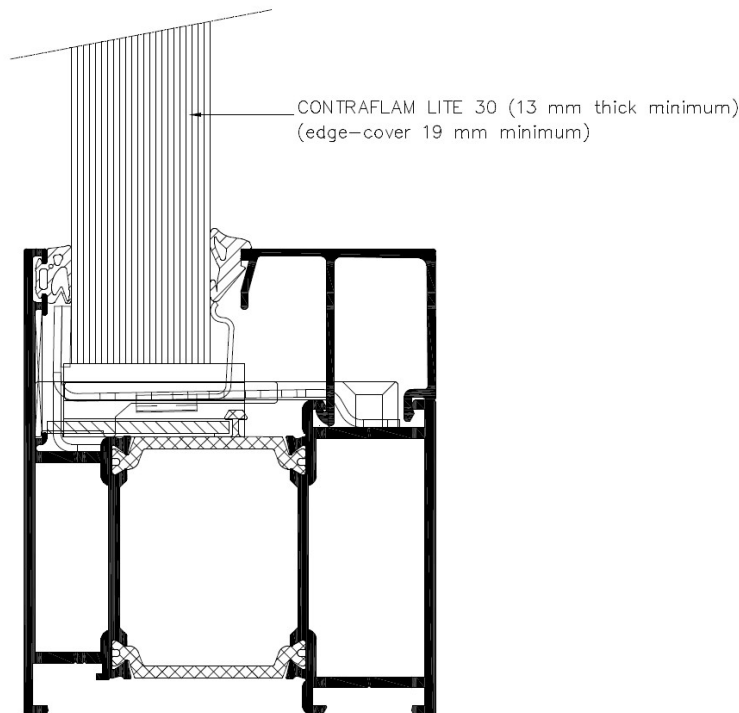

Table 12 – Maximum Permitted Glass Dimensions		
Max. Width (mm)	Max. Height (mm)	Max. Area (m2)
1740 (at 3000 high)	3480 (at 1500 wide)	5.22

## CERTIFICATE No CF811

### Vetrotech Saint-Gobain International AG

#### Contraflam Lite 30 Glass in Schuco ADS65 Ni FR 30 aluminium framed screens for periods of 30 minutes integrity

The glass shall be installed into the Schuco ADS65 Ni FR30 aluminium framing system (which is covered appropriately by test or assessment evidence).

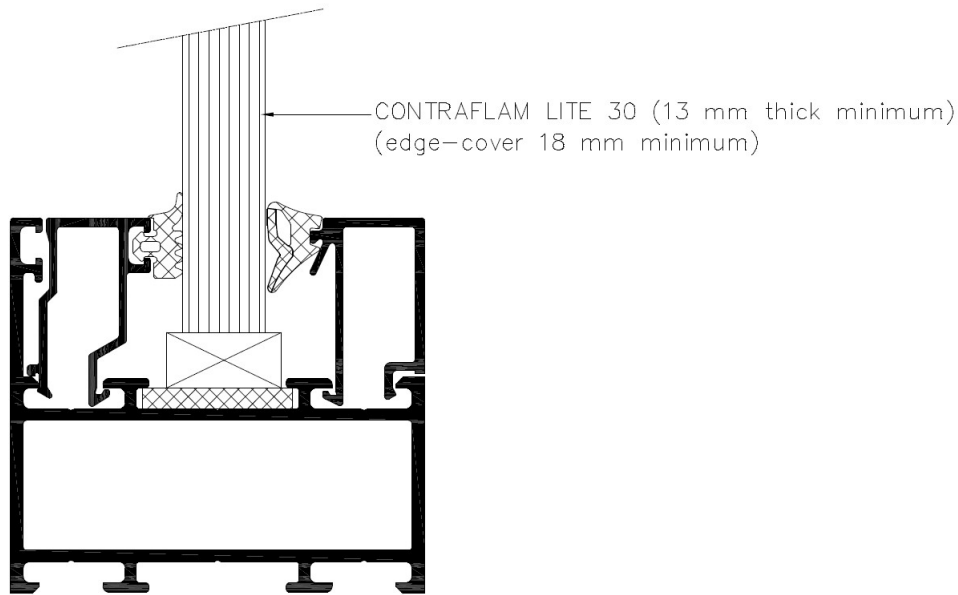

Max. Width (mm)	Max. Height (mm)	Max. Area (m2)
2400 (at 1400 high)	1680 (at 2000 wide)	3.36
1730 (at 2898 high)	3622 (at 1384 wide)	5.01

## CERTIFICATE No CF811

### Vetrotech Saint-Gobain International AG

#### Contraflam Lite 30 Climaplus Glass in steel framed screens for periods of 30 minutes integrity

The glass shall be installed into a previously tested or CERTIFIRE approved framing system (which is covered appropriately by test or assessment evidence) using pressure plate glazing, screw-fixed or clip-on retaining beads, see examples below. The glass shall be glazed into the screen as described in the table below and set on non-combustible setting blocks to determine the correct edge cover.

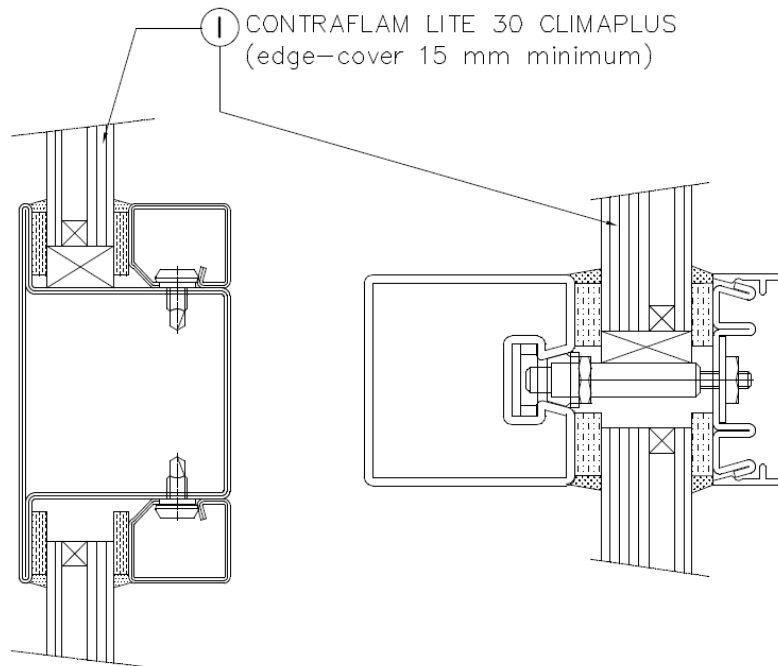

Max. Width (mm)	Max. Height (mm)	Max. Area (m <sup>2</sup> )
2300 (at 3800 high)	3800 (at 2300 wide)	8.74

## CERTIFICATE No CF811

### Vetrotech Saint-Gobain International AG

#### Contraflam Lite 30 Climaplus Glass in timber framed screens for periods of 30 minutes integrity

The glass shall be glazed utilising the following basic specification:

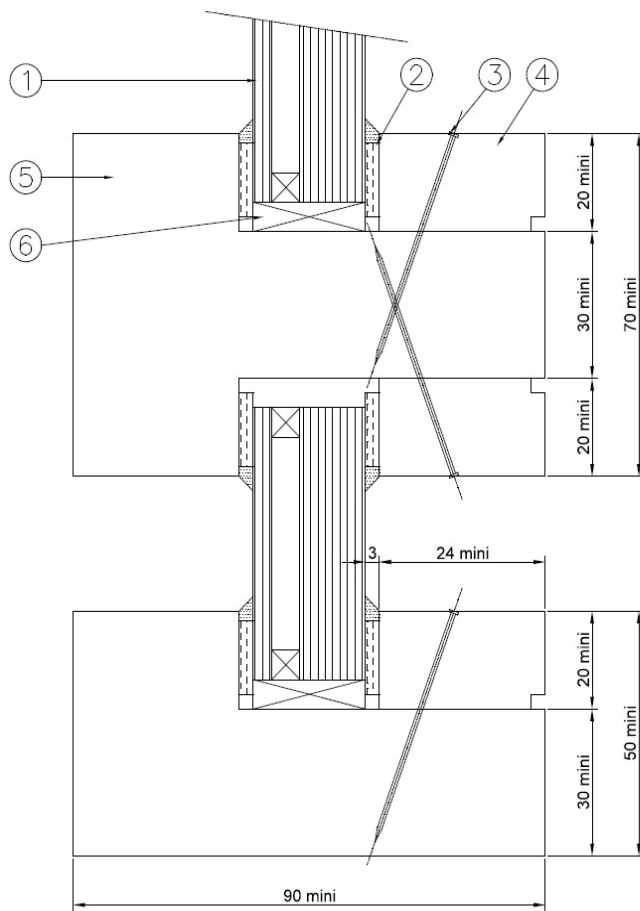

- ① CONTRAFLAM LITE 30 CLIMAPLUS (edge-cover 15 mm)
- ② Kuhn Kerafix 2000 Tape 3 x 15 mm, topped with neutral curing silicone
- ③ Ø 1.8 x 40 mm long steel pins at 150 mm centres
- ④ Minimum 20 x 24 mm (h x w) timber glazing beads minimum density 465 kg/m<sup>3</sup>
- ⑤ Minimum 90 x 50 mm outer timber framing section & 90 x 70 mm intermediate timber framing section. Minimum density 465 kg/m<sup>3</sup>
- ⑥ Non-combustible / hardwood setting blocks glass thickness x 5 x 80 mm (w x h x d) (2 pieces per glass, on the bottom only)

Table 15 – Maximum Permitted Glass Dimensions		
Max. Width (mm)	Max. Height (mm)	Max. Area (m <sup>2</sup> )
1875 (at 3000 high)	3750 (at 1500 wide)	5.62

## CERTIFICATE No CF811

### Vetrotech Saint-Gobain International AG

**Contraflam Lite 30 Climaplus in timber framed screens for periods of 30 minutes integrity and 15 minutes insulation**

The glass shall be glazed utilising the following basic specification:

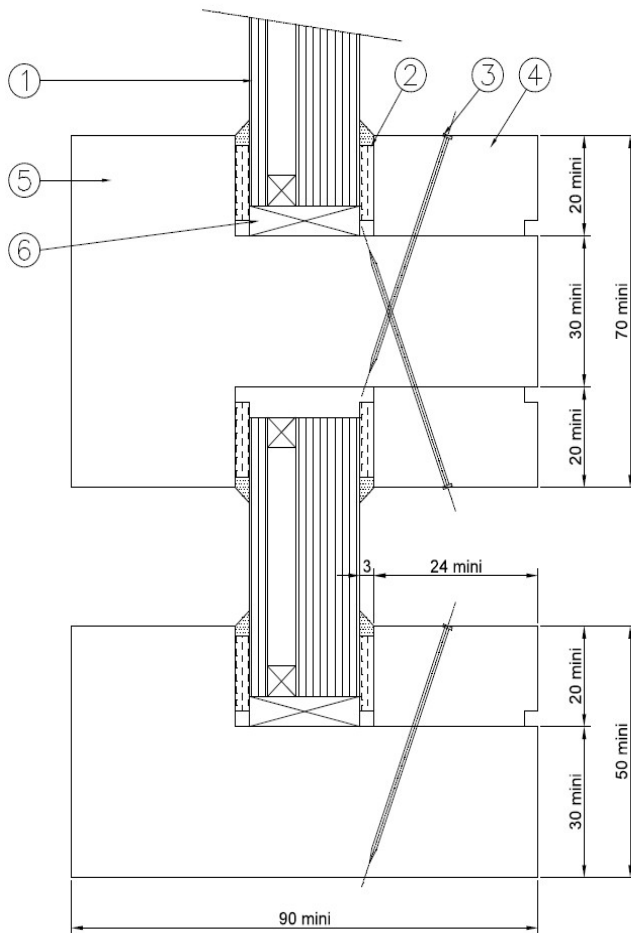

- ① CONTRAFLAM LITE 30 CLIMAPLUS (edge-cover 15 mm)
- ② Kuhn Kerafix 2000 Tape 3 x 15 mm, topped with neutral curing silicone
- ③ Ø 1.8 x 40 mm long steel pins at 150 mm centres
- ④ Minimum 20 x 24 mm (h x w) timber glazing beads minimum density 465 kg/m<sup>3</sup>
- ⑤ Minimum 90 x 50 mm outer timber framing section & 90 x 70 mm intermediate timber framing section. Minimum density 465 kg/m<sup>3</sup>
- ⑥ Non-combustible / hardwood setting blocks glass thickness x 5 x 80 mm (w x h x d) (2 pieces per glass, on the bottom only)

**Table 16 – Maximum Permitted Glass Dimensions**

Max. Width (mm)	Max. Height (mm)	Max. Area (m <sup>2</sup> )
3800 (at 2300 high)	2300 (at 3800 wide)	8.74

## CERTIFICATE No CF811

### Vetrotech Saint-Gobain International AG

**Contraflam Lite 30 Horizontal Climaplus Glass in Schuco FW 50+ BF aluminium framed screens, in a horizontal orientation, for periods of 30 minutes integrity**

The glass shall be installed into the Schuco FW 50+ BF aluminium framing system (which is covered appropriately by test or assessment evidence).

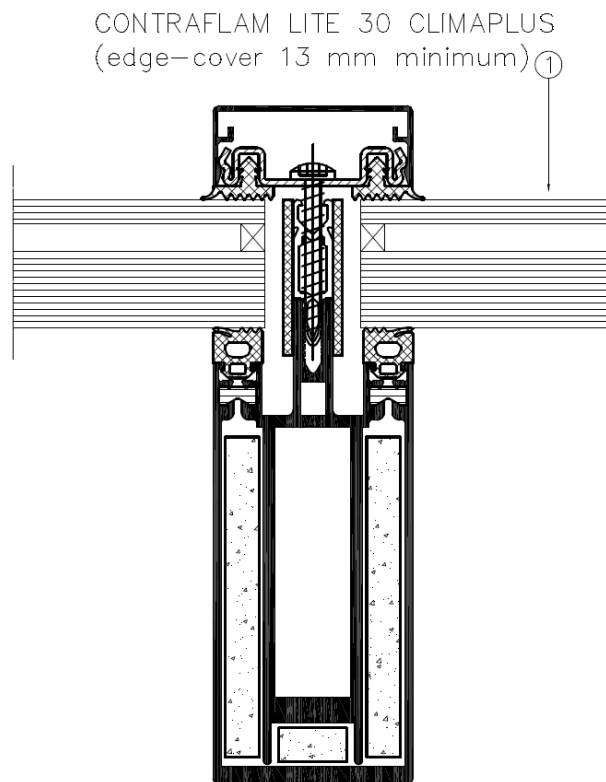

The construction may be installed between 0° and 80° (from the horizontal).

Table 17 – Maximum Permitted Glass Dimensions		
Max. Width (mm)	Max. Height (mm)	Max. Area (m2)
1236 (at 2400 high)	2472 (at 1200 wide)	2.97
2266 (at 1100 high)	1133 (at 2200 wide)	2.49

## CERTIFICATE No CF811

### Vetrotech Saint-Gobain International AG

**Contraflam Lite 30 Climaplus Glass in Schüco FW 50+ BF aluminium framed screens for periods of 30 minutes integrity and 15 minutes insulation**

The glass shall be installed into the Schuco FW 50+ BF aluminium framing system (which is covered appropriately by test or assessment evidence).

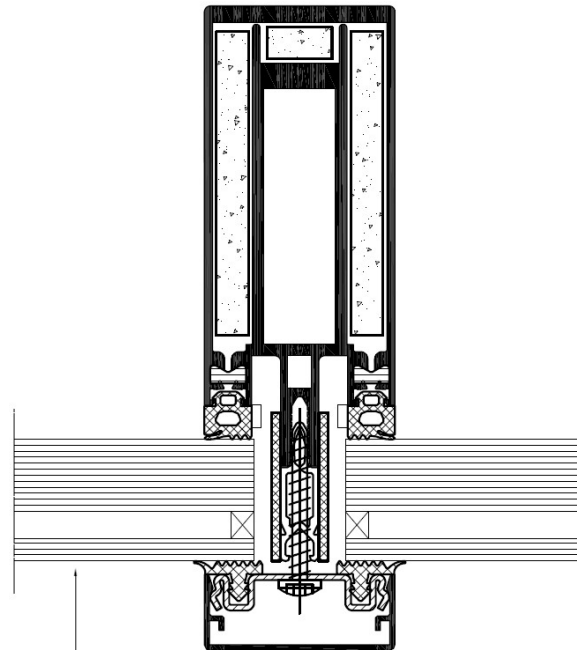

① CONTRAFLAM LITE 30 CLIMAPLUS  
(edge-cover 13 mm minimum)

Table 18 – Maximum Permitted Glass Dimensions		
Max. Width (mm)	Max. Height (mm)	Max. Area (m <sup>2</sup> )
2300 (at 3800 high)	3800 (at 2300 wide)	8.74

## CERTIFICATE No CF811

### Vetrotech Saint-Gobain International AG

#### Contraflam Lite 60 Glass in steel framed screens for periods of 60 minutes integrity

The glass shall be installed into a previously tested or CERTIFIRE approved framing system (which is covered appropriately by test or assessment evidence) using pressure plate glazing, screw-fixed or clip-on retaining beads, see examples below. The glass shall be glazed into the screen as described in the table below and set on non-combustible setting blocks to determine the correct edge cover.

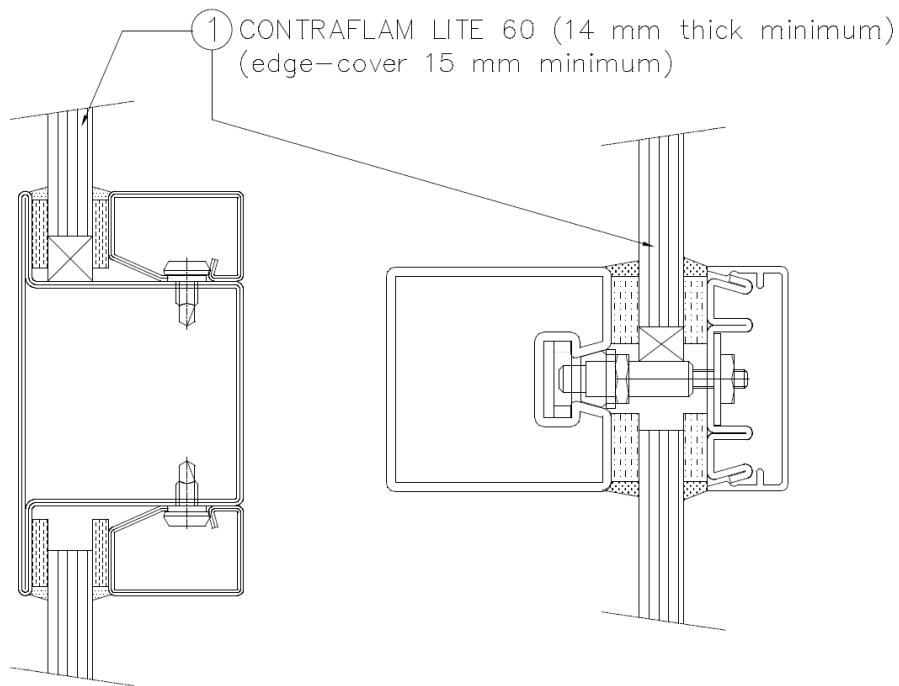

Table 19 – Maximum Permitted Glass Dimensions		
Max. Width (mm)	Max. Height (mm)	Max. Area (m <sup>2</sup> )
2300 (at 3260 high)	3750 (at 2000 wide)	7.5

## CERTIFICATE No CF811

### Vetrotech Saint-Gobain International AG

#### Contraflam Lite 60 Glass in steel framed screens for periods of 60 minutes integrity and 15 minutes insulation

The glass shall be installed into a previously tested or CERTIFIRE approved framing system (which is covered appropriately by test or assessment evidence) using pressure plate glazing, screw-fixed or clip-on retaining beads, see examples below. The glass shall be glazed into the screen as described in the table below and set on non-combustible setting blocks to determine the correct edge cover.

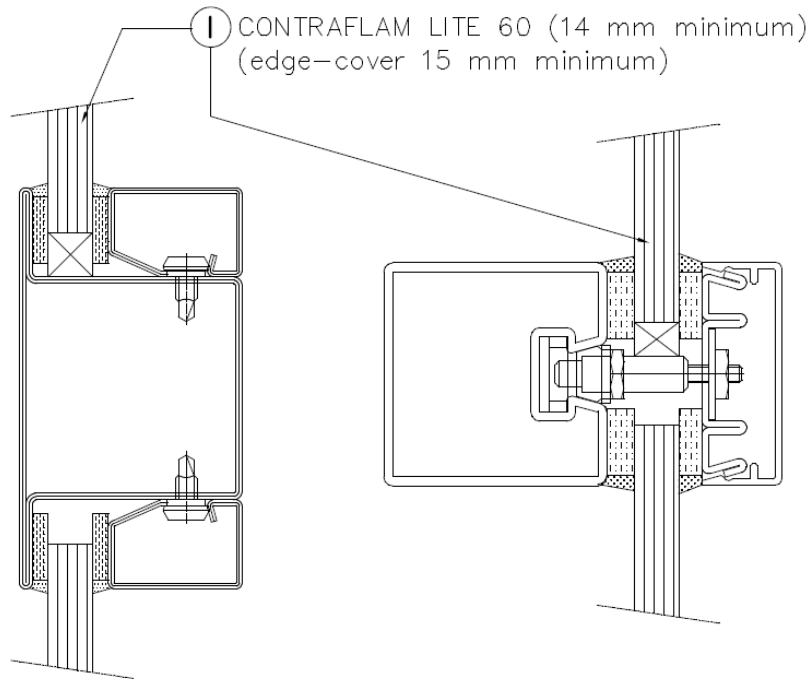

Max. Width (mm)	Max. Height (mm)	Max. Area (m <sup>2</sup> )
2037 (at 2940 high)	3675 (at 1630 wide)	5.99
2825 (at 1500 high)	1695 (at 2500 wide)	4.23

## CERTIFICATE No CF811

### Vetrotech Saint-Gobain International AG

**Contraflam Lite 60 Glass in timber framed screens for periods of 60 minutes integrity and 15 minutes insulation**

The glass shall be glazed utilising the following basic specification:

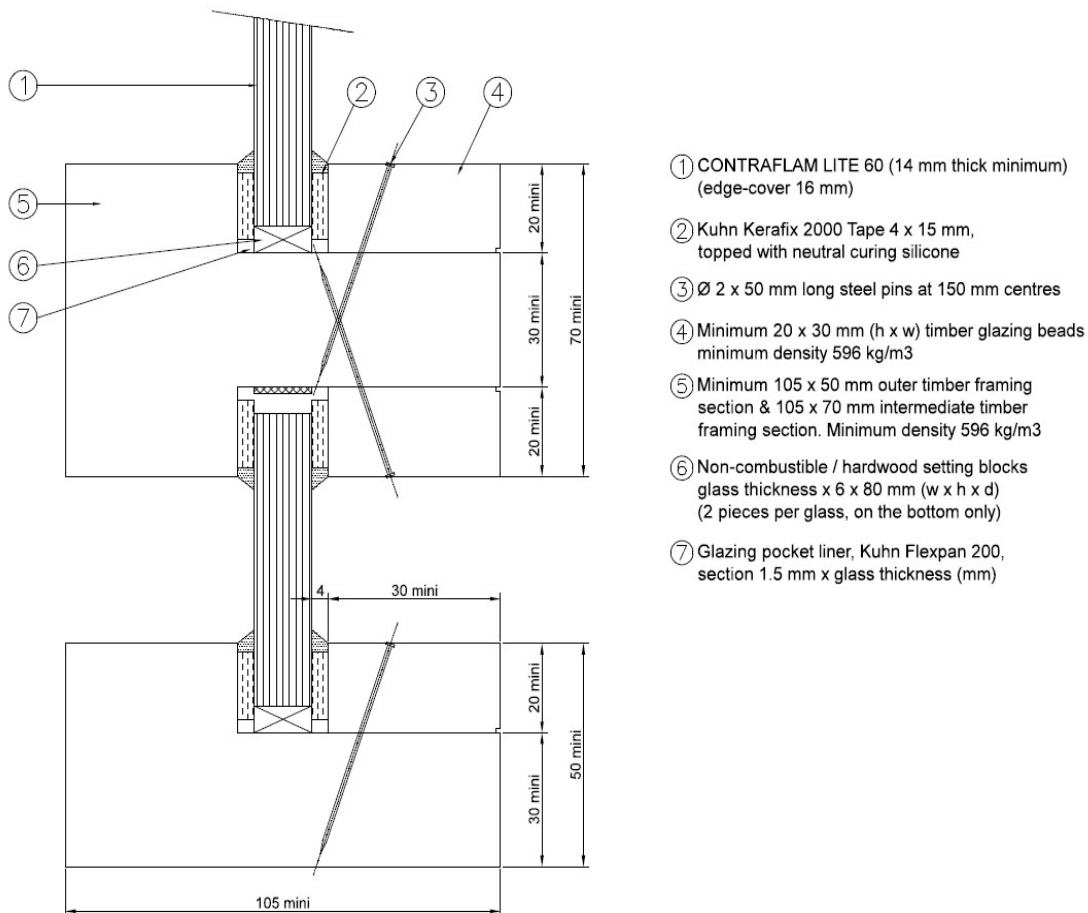

**Table 21 – Maximum Permitted Glass Dimensions**

Max. Width (mm)	Max. Height (mm)	Max. Area (m <sup>2</sup> )
3800 (at 2300 high)	2300 (at 3800 wide)	8.74

## CERTIFICATE No CF811

### Vetrotech Saint-Gobain International AG

#### Contraflam Lite 60 Climaplus Glass in steel framed screens for periods of 60 minutes integrity

The glass shall be installed into a previously tested or CERTIFIRE approved framing system (which is covered appropriately by test or assessment evidence) using pressure plate glazing, screw-fixed or clip-on retaining beads, see examples below. The glass shall be glazed into the screen as described in the table below and set on non-combustible setting blocks to determine the correct edge cover.

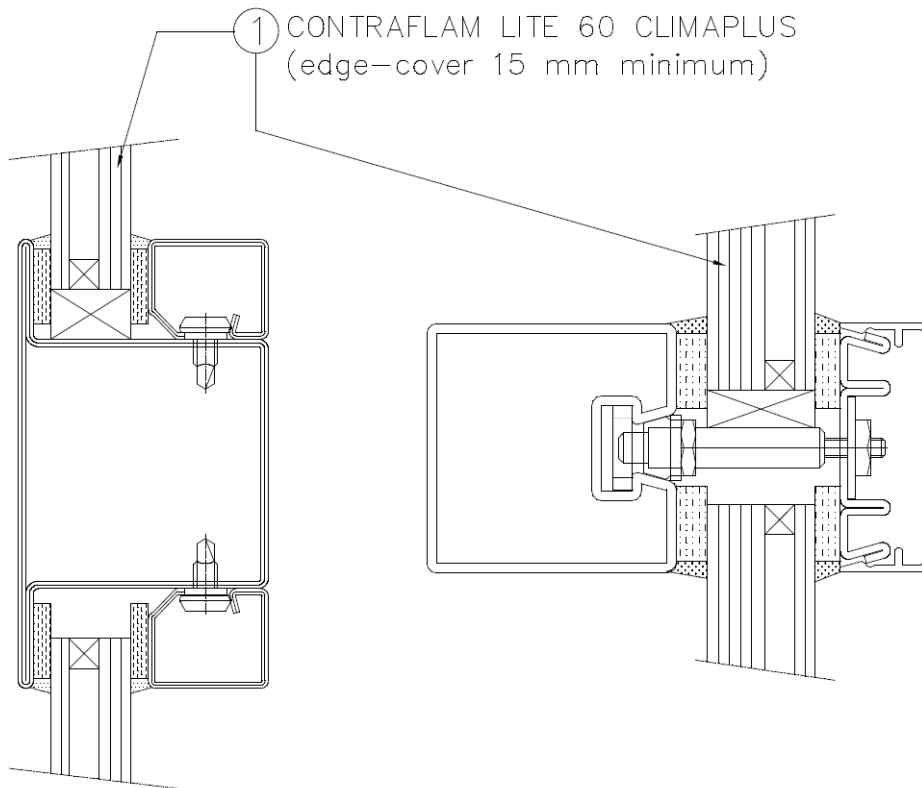

Max. Width (mm)	Max. Height (mm)	Max. Area (m <sup>2</sup> )
1875 (at 3000 high)	3750 (at 1500 wide)	5.62

## CERTIFICATE No CF811

### Vetrotech Saint-Gobain International AG

#### Contraflam Lite 60 Climaplus Glass in steel framed screens for periods of 60 minutes integrity and 15 minutes insulation

The glass shall be installed into a previously tested or CERTIFIRE approved framing system (which is covered appropriately by test or assessment evidence) using pressure plate glazing, screw-fixed or clip-on retaining beads, see examples below. The glass shall be glazed into the screen as described in the table below and set on non-combustible setting blocks to determine the correct edge cover.

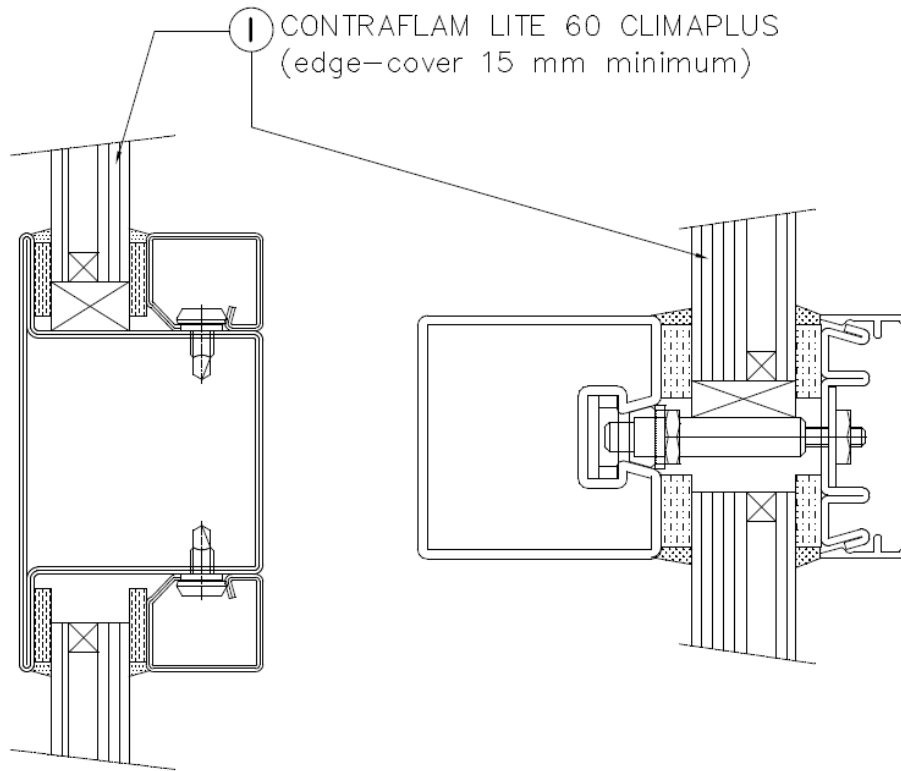

Table 23 – Maximum Permitted Glass Dimensions		
Max. Width (mm)	Max. Height (mm)	Max. Area (m <sup>2</sup> )
2037 (at 2940 high)	3675 (at 1630 wide)	5.99

## CERTIFICATE No CF811

### Vetrotech Saint-Gobain International AG

**Contraflam Lite 60 Climaplus Glass in timber framed screens for periods of 60 minutes integrity**

The glass shall be glazed utilising the following basic specification:

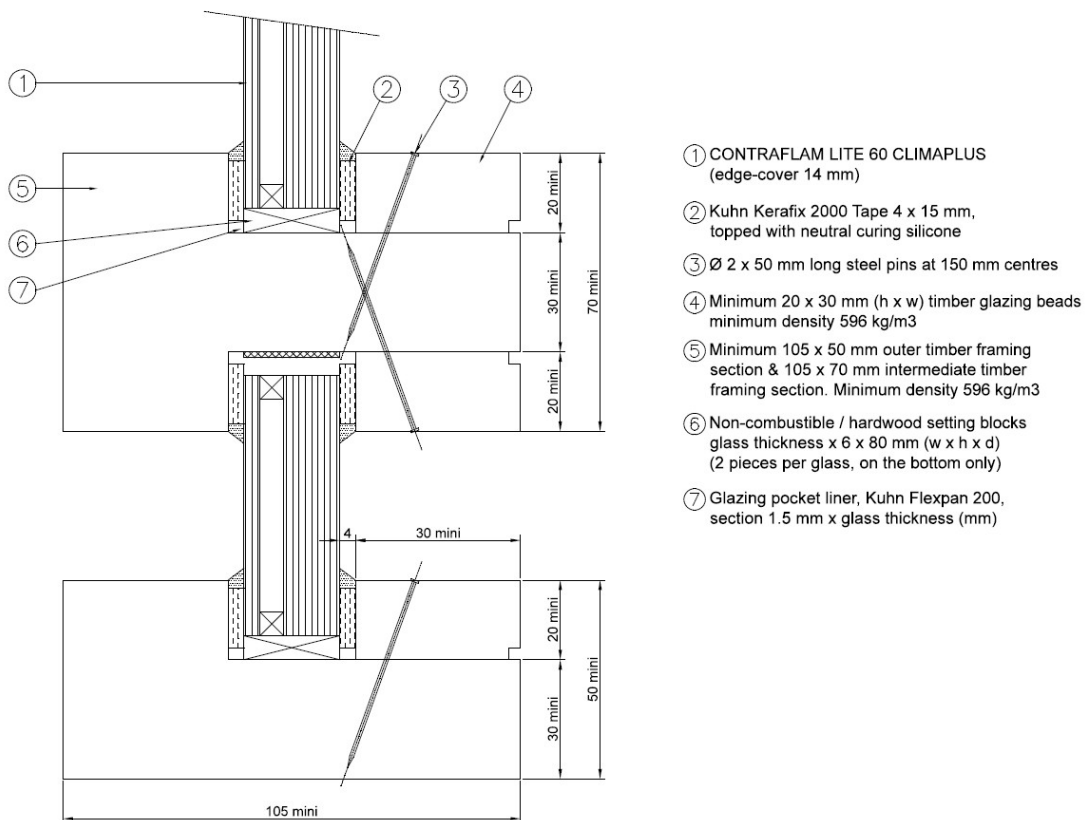

- ① CONTRAFLAM LITE 60 CLIMAPLUS (edge-cover 14 mm)
- ② Kuhn Kerafix 2000 Tape 4 x 15 mm, topped with neutral curing silicone
- ③ Ø 2 x 50 mm long steel pins at 150 mm centres
- ④ Minimum 20 x 30 mm (h x w) timber glazing beads minimum density 596 kg/m<sup>3</sup>
- ⑤ Minimum 105 x 50 mm outer timber framing section & 105 x 70 mm intermediate timber framing section. Minimum density 596 kg/m<sup>3</sup>
- ⑥ Non-combustible / hardwood setting blocks glass thickness x 6 x 80 mm (w x h x d) (2 pieces per glass, on the bottom only)
- ⑦ Glazing pocket liner, Kuhn Flexpan 200, section 1.5 mm x glass thickness (mm)

Max. Width (mm)	Max. Height (mm)	Max. Area (m <sup>2</sup> )
1875 (at 3000 high)	3750 (at 1500 wide)	5.62
3800 (at 2300 high)	2300 (at 3800 wide)	8.74

## CERTIFICATE No CF811

### Vetrotech Saint-Gobain International AG

**Contraflam Lite 60 Climaplus Glass in timber framed screens for periods of 60 minutes integrity and 15 minutes insulation**

The glass shall be glazed utilising the following basic specification:

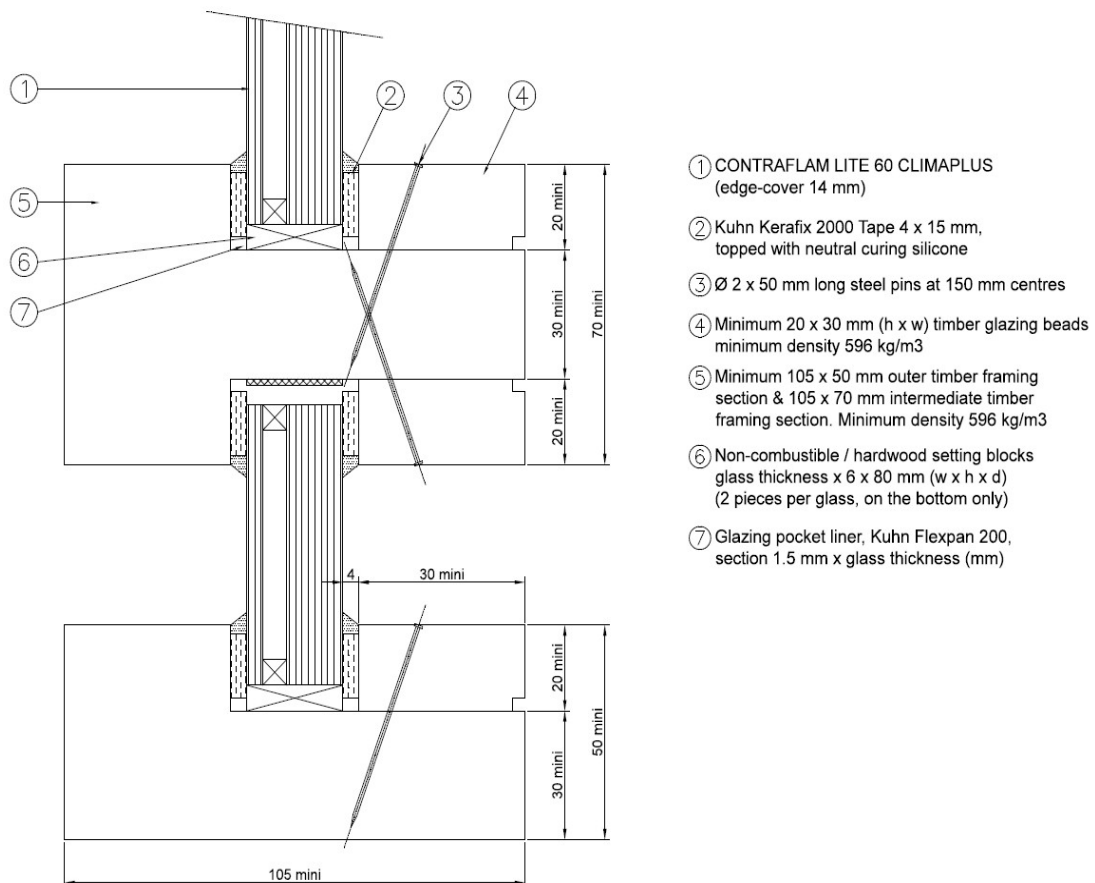

- ① CONTRAFLAM LITE 60 CLIMAPLUS (edge-cover 14 mm)
- ② Kuhn Kerafix 2000 Tape 4 x 15 mm, topped with neutral curing silicone
- ③ Ø 2 x 50 mm long steel pins at 150 mm centres
- ④ Minimum 20 x 30 mm (h x w) timber glazing beads minimum density 596 kg/m<sup>3</sup>
- ⑤ Minimum 105 x 50 mm outer timber framing section & 105 x 70 mm intermediate timber framing section. Minimum density 596 kg/m<sup>3</sup>
- ⑥ Non-combustible / hardwood setting blocks glass thickness x 6 x 80 mm (w x h x d) (2 pieces per glass, on the bottom only)
- ⑦ Glazing pocket liner, Kuhn Flexpan 200, section 1.5 mm x glass thickness (mm)

Max. Width (mm)	Max. Height (mm)	Max. Area (m <sup>2</sup> )
2037 (at 2940 high)	3675 (at 1630 wide)	5.99

## CERTIFICATE No CF811

### Vetrotech Saint-Gobain International AG

**Contraflam Lite 60 Climaplus Glass in Kawneer AA110 FR aluminium framed screens for periods of 60 minutes integrity and 15 minutes insulation**

The glass shall be installed into the Kawneer AA110 FR aluminium framing system (which is covered appropriately by test or assessment evidence).

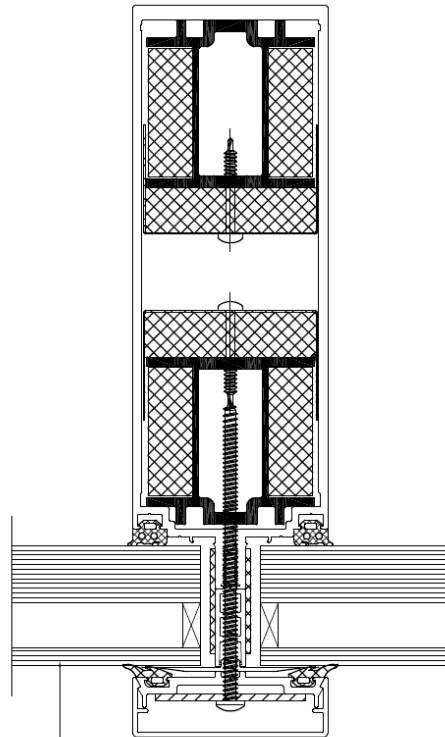

① CONTRAFLAM LITE 60 CLIMAPLUS  
(edge-cover 22 mm minimum)

Table 26 – Maximum Permitted Glass Dimensions		
Max. Width (mm)	Max. Height (mm)	Max. Area (m <sup>2</sup> )
2300 (at 3000 high)	3630 (at 1902 wide)	6.90

## CERTIFICATE No CF811

### Vetrotech Saint-Gobain International AG

#### Contraflam Lite 90 Glass in steel framed screens for periods of 90 minutes integrity

The glass shall be installed into a previously tested or CERTIFIRE approved framing system (which is covered appropriately by test or assessment evidence) using pressure plate glazing, screw-fixed or clip-on retaining beads, see examples below. The glass shall be glazed into the screen as described in the table below and set on non-combustible setting blocks to determine the correct edge cover.

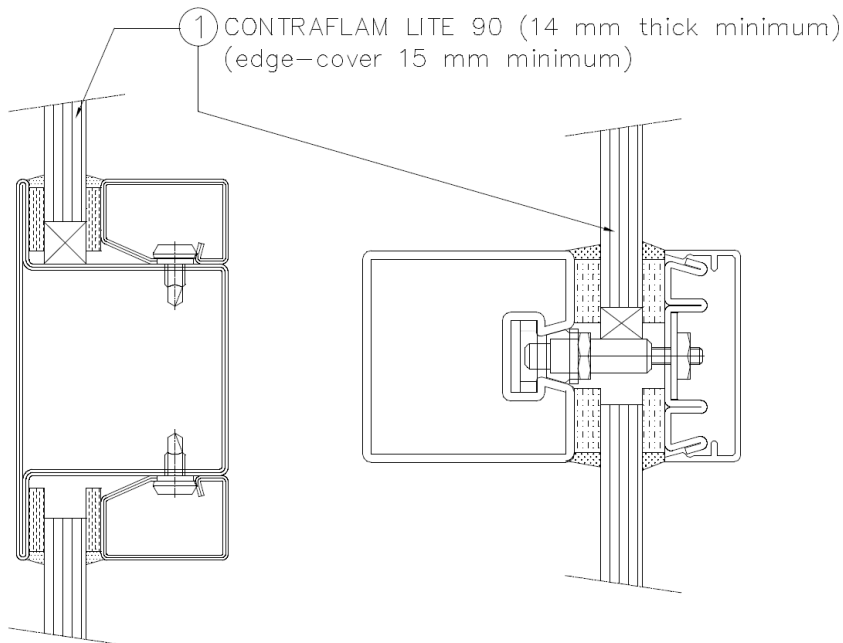

Table 27 – Maximum Permitted Glass Dimensions		
Max. Width (mm)	Max. Height (mm)	Max. Area (m <sup>2</sup> )
1800 (at 3500 high)	3500 (at 1800 wide)	6.3
2000 (at 3000 high)	3000 (at 2000 wide)	6.0

**Note: If applicable, a STADIP laminated glass used in the composition of the Contraflam unit is allowable, but on the fire side only.**

## CERTIFICATE No CF811

### Vetrotech Saint-Gobain International AG

#### Contraflam Lite 90 Glass in timber framed screens for periods of 90 minutes integrity

The glass shall be glazed utilising the following basic specification:

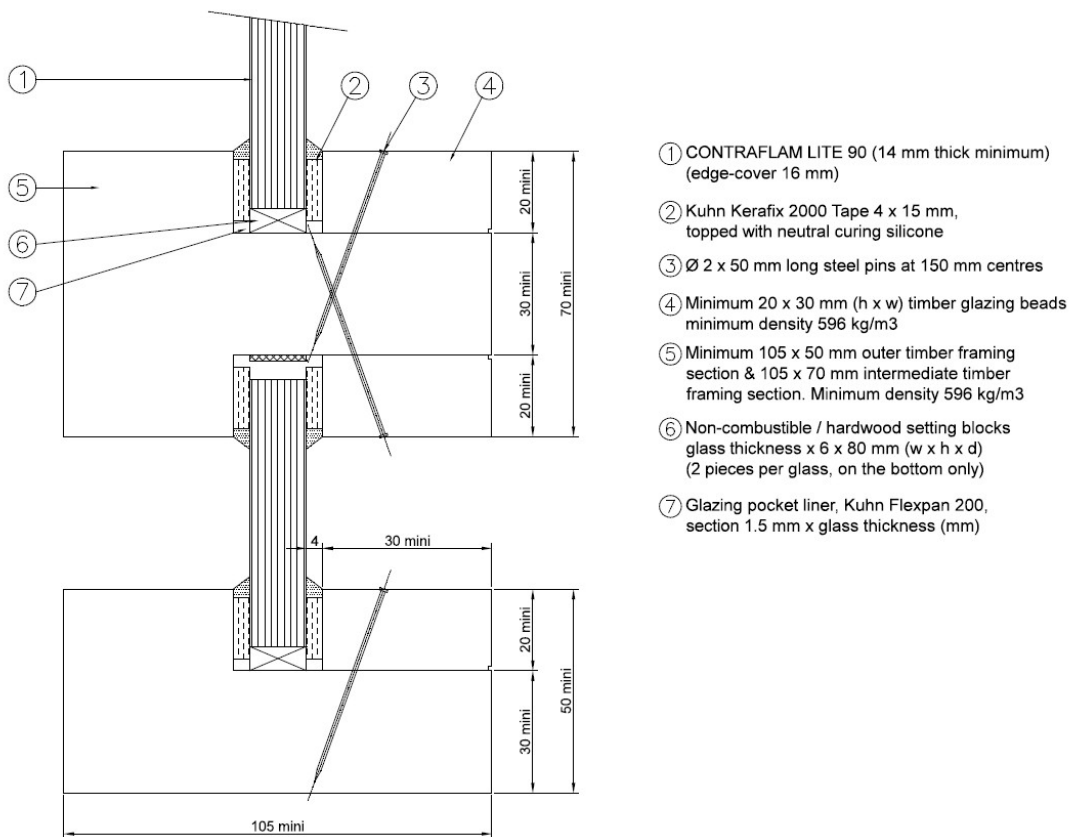

- ① CONTRAFLAM LITE 90 (14 mm thick minimum) (edge-cover 16 mm)
- ② Kuhn Kerafix 2000 Tape 4 x 15 mm, topped with neutral curing silicone
- ③ Ø 2 x 50 mm long steel pins at 150 mm centres
- ④ Minimum 20 x 30 mm (h x w) timber glazing beads minimum density 596 kg/m<sup>3</sup>
- ⑤ Minimum 105 x 50 mm outer timber framing section & 105 x 70 mm intermediate timber framing section. Minimum density 596 kg/m<sup>3</sup>
- ⑥ Non-combustible / hardwood setting blocks glass thickness x 6 x 80 mm (w x h x d) (2 pieces per glass, on the bottom only)
- ⑦ Glazing pocket liner, Kuhn Flexpan 200, section 1.5 mm x glass thickness (mm)

Max. Width (mm)	Max. Height (mm)	Max. Area (m <sup>2</sup> )
1400 (at 2230 high)	2230 (at 1400 wide)	3.12

**Note: If applicable, a STADIP laminated glass used in the composition of the Contraflam unit is allowable, but on the fire side only.**

## CERTIFICATE No CF811

### Vetrotech Saint-Gobain International AG

#### Contraflam Lite 90 Climaplus Glass in steel framed screens for periods of 90 minutes integrity

The glass shall be installed into a previously tested or CERTIFIRE approved framing system (which is covered appropriately by test or assessment evidence) using pressure plate glazing, screw-fixed or clip-on retaining beads, see examples below. The glass shall be glazed into the screen as described in the table below and set on non-combustible setting blocks to determine the correct edge cover.

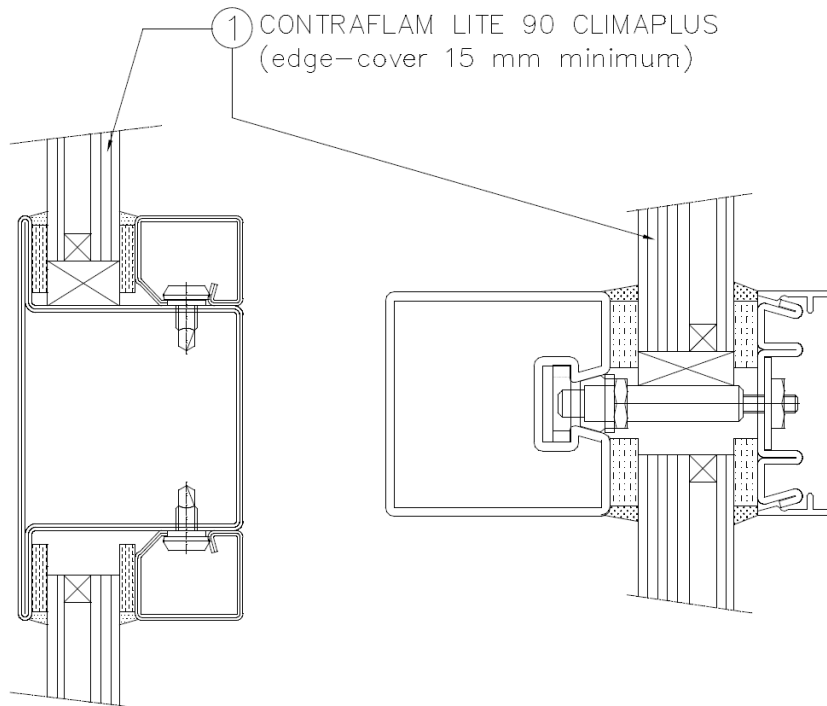

Table 29 – Maximum Permitted Glass Dimensions		
Max. Width (mm)	Max. Height (mm)	Max. Area (m <sup>2</sup> )
1800 (at 3260 high)	3800 (at 1500 wide)	5.70

**Note:** If applicable, a STADIP laminated counterpane or STADIP laminated glass used in the composition of the Contraflam unit is allowable, but on the fire side only.

## CERTIFICATE No CF811

### Vetrotech Saint-Gobain International AG

#### Contraflam Lite 90 Climaplus Glass in steel framed screens for periods of 90 minutes integrity and 15 minutes insulation

The glass shall be installed into a previously tested or CERTIFIRE approved framing system (which is covered appropriately by test or assessment evidence) using pressure plate glazing, screw-fixed or clip-on retaining beads, see examples below. The glass shall be glazed into the screen as described in the table below and set on non-combustible setting blocks to determine the correct edge cover.

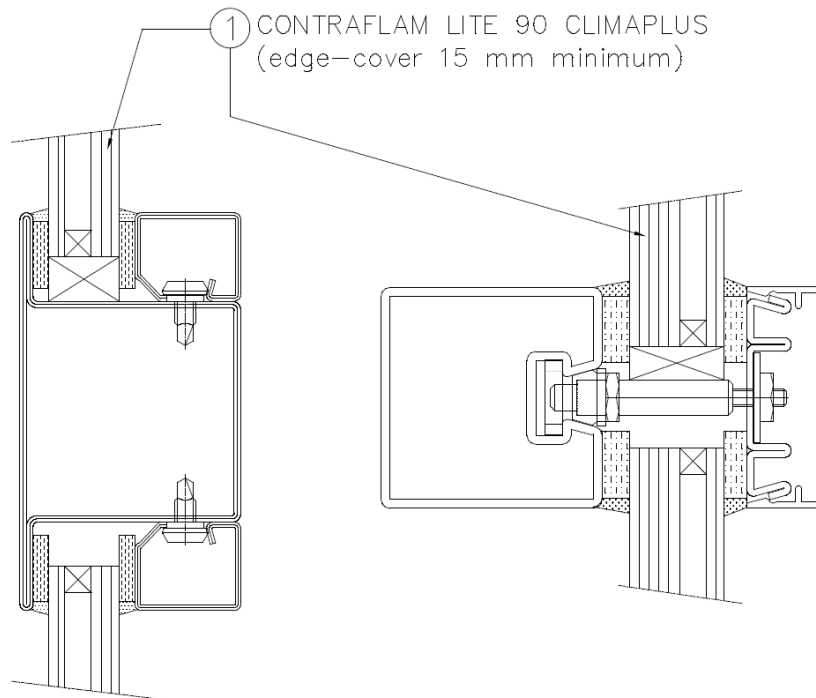

Table 30 – Maximum Permitted Glass Dimensions		
Max. Width (mm)	Max. Height (mm)	Max. Area (m <sup>2</sup> )
1000 (at 2000 high)	2000 (at 1000 wide)	2.0

**Note:** If applicable, a STADIP laminated counterpane or STADIP laminated glass used in the composition of the Contraflam unit is allowable, but on the fire side only.

## CERTIFICATE No CF811

### Vetrotech Saint-Gobain International AG

**Contraflam Lite 90 Climaplus Glass in timber framed screens for periods of 90 minutes integrity**

The glass shall be glazed utilising the following basic specification:

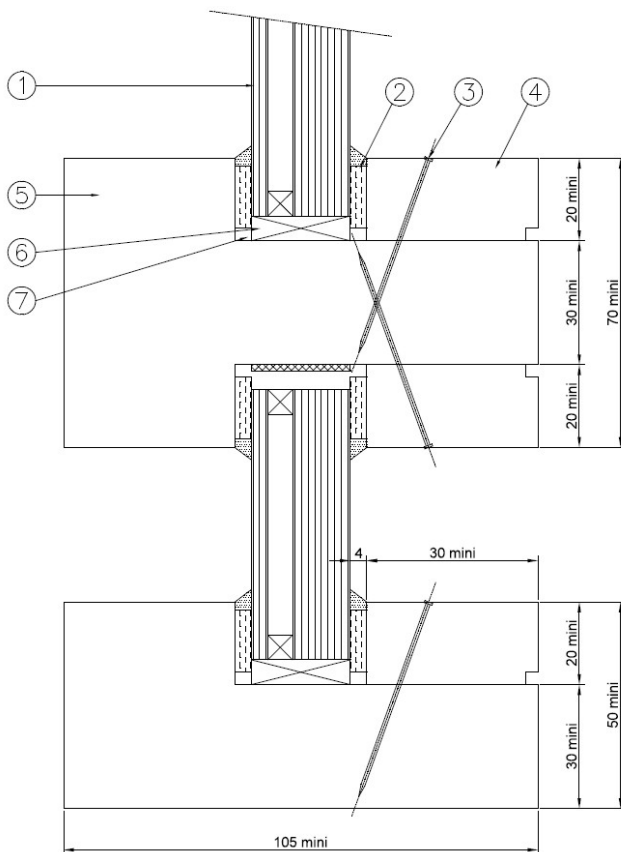

- ① CONTRAFLAM LITE 90 CLIMAPLUS (edge-cover 14 mm)
- ② Kuhn Kerafix 2000 Tape 4 x 15 mm, topped with neutral curing silicone
- ③ Ø 2 x 50 mm long steel pins at 150 mm centres
- ④ Minimum 20 x 30 mm (h x w) timber glazing beads minimum density 596 kg/m<sup>3</sup>
- ⑤ Minimum 105 x 50 mm outer timber framing section & 105 x 70 mm intermediate timber framing section. Minimum density 596 kg/m<sup>3</sup>
- ⑥ Non-combustible / hardwood setting blocks glass thickness x 6 x 80 mm (w x h x d) (2 pieces per glass, on the bottom only)
- ⑦ Glazing pocket liner, Kuhn Flexpan 200, section 1.5 mm x glass thickness (mm)

**Table 31 – Maximum Permitted Glass Dimensions**

Max. Width (mm)	Max. Height (mm)	Max. Area (m <sup>2</sup> )
1430 (at 1730 high)	1730 (at 1430 wide)	2.47

**Note: If applicable, a STADIP laminated counterpane or STADIP laminated glass used in the composition of the Contraflam unit is allowable, but on the fire side only.**

## CERTIFICATE No CF811

### Vetrotech Saint-Gobain International AG

#### Contraflam Lite 120 Glass in steel framed screens for periods of 120 minutes integrity

The glass shall be installed into a previously tested or CERTIFIRE approved framing system (which is covered appropriately by test or assessment evidence) using pressure plate glazing, screw-fixed or clip-on retaining beads, see examples below. The glass shall be glazed into the screen as described in the table below and set on non-combustible setting blocks to determine the correct edge cover.

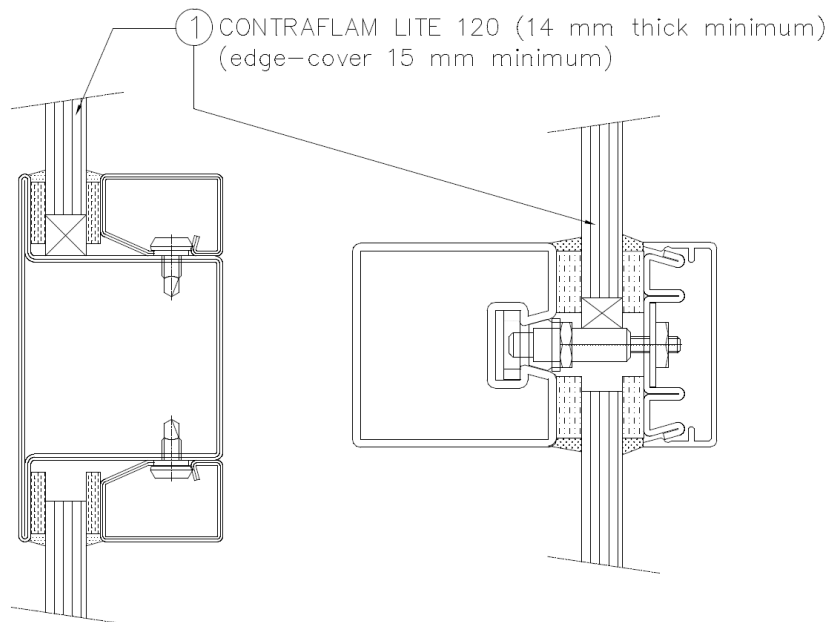

Max. Width (mm)	Max. Height (mm)	Max. Area (m <sup>2</sup> )
2000 (at 3000 high)	3000 (at 2000 wide)	6.0

**Note:** If applicable, a STADIP laminated glass used in the composition of the Contraflam unit is allowable, but on the fire side only.

## CERTIFICATE No CF811

### Vetrotech Saint-Gobain International AG

#### Contraflam Lite 120 Climaplus (low-e or solar controlled coating) Glass in steel framed screens for periods of 120 minutes integrity

The glass shall be installed into a previously tested or CERTIFIRE approved framing system (which is covered appropriately by test or assessment evidence) using pressure plate glazing, screw-fixed or clip-on retaining beads, see examples below. The glass shall be glazed into the screen as described in the table below and set on non-combustible setting blocks to determine the correct edge cover.

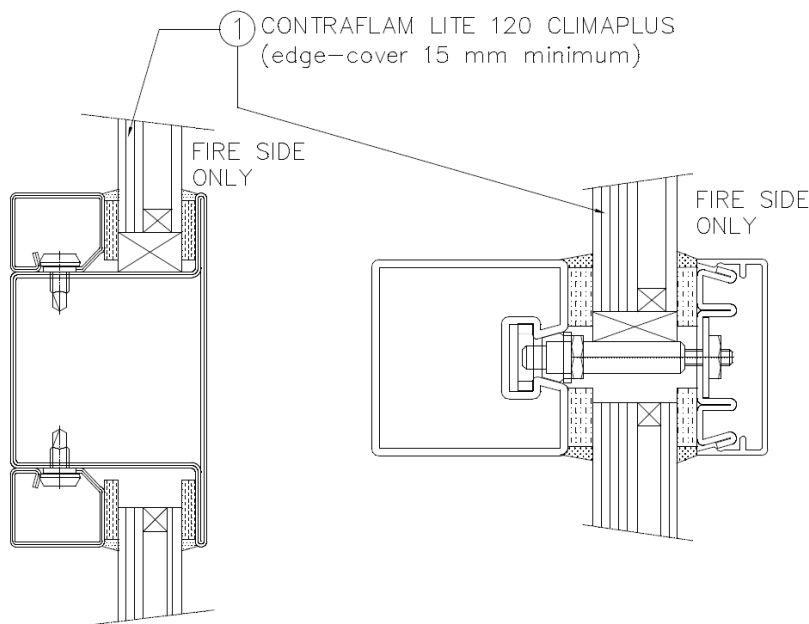

Max. Width (mm)	Max. Height (mm)	Max. Area (m2)
1480 (at 2880 high)	2880 (at 1480 wide)	4.26

**Note:** If applicable, a STADIP laminated counterpane or STADIP laminated glass used in the composition of the Contraflam unit is allowable, but on the fire side only.

**Note:** Where the counterpane of the IGU has a low-e or solar controlled coating, it shall be limited to use on the exposed face only. i.e. fire side to counter pane side only.

## CERTIFICATE No CF811

### Vetrotech Saint-Gobain International AG

#### Contraflam Lite 120 Climalit (no low-e or solar controlled coating) Glass in steel framed screens for periods of 120 minutes integrity

The glass shall be installed into a previously tested or CERTIFIRE approved framing system (which is covered appropriately by test or assessment evidence) using pressure plate glazing, screw-fixed or clip-on retaining beads, see examples below. The glass shall be glazed into the screen as described in the table below and set on non-combustible setting blocks to determine the correct edge cover.

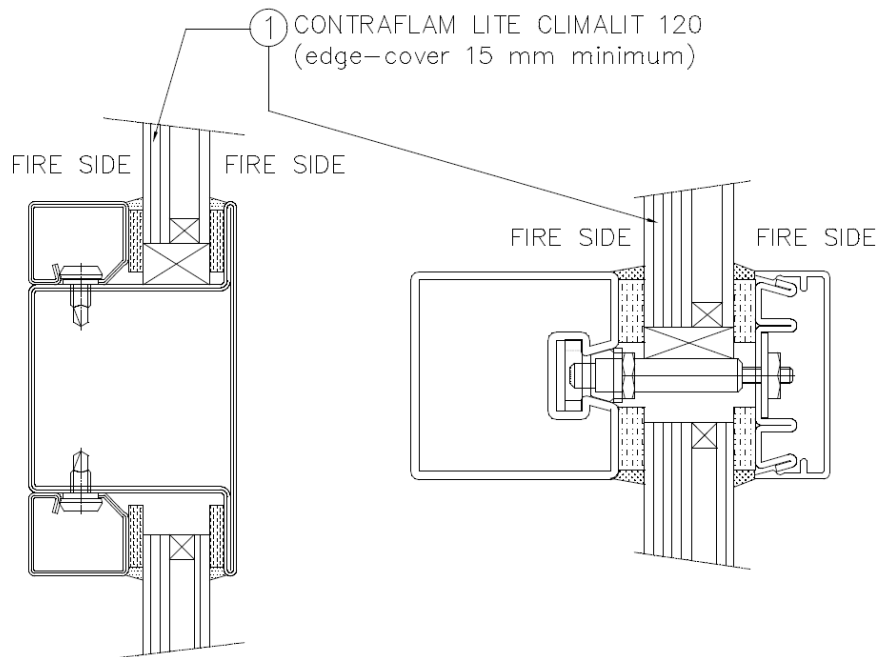

Max. Width (mm)	Max. Height (mm)	Max. Area (m <sup>2</sup> )
1480 (at 2880 high)	2880 (at 1480 wide)	4.26

**Note:** If applicable, a STADIP laminated counterpane or STADIP laminated glass used in the composition of the Contraflam unit is allowable, but on the fire side only.

**Note:** This construction may be oriented in either direction. i.e. fire side to both sides.

## CERTIFICATE No CF811

### Vetrotech Saint-Gobain International AG

#### Contraflam 30 Glass in steel framed screens for periods of 30 minutes integrity and 30 minutes insulation

The glass shall be installed into a previously tested or CERTIFIRE approved framing system (which is covered appropriately by test or assessment evidence) using pressure plate glazing, screw-fixed or clip-on retaining beads, see examples below. The glass shall be glazed into the screen as described in the table below and set on non-combustible setting blocks to determine the correct edge cover.

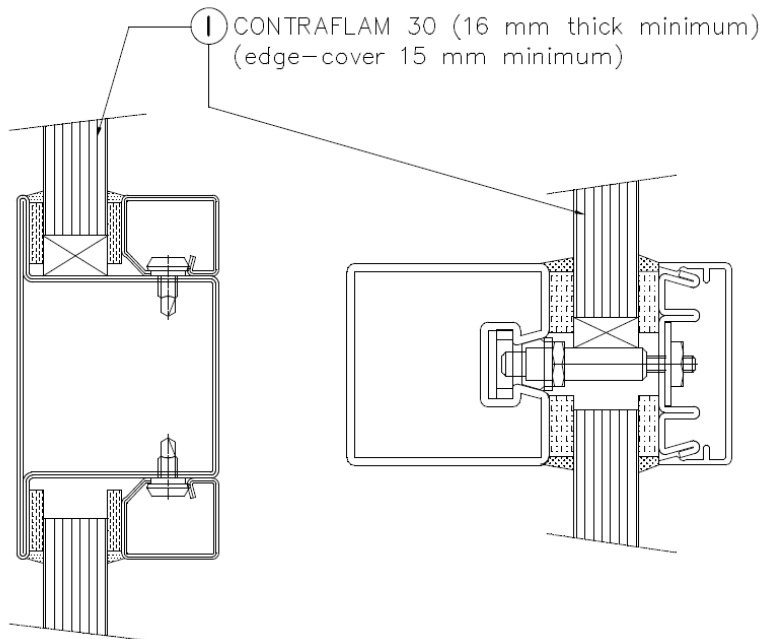

Max. Width (mm)	Max. Height (mm)	Max. Area (m <sup>2</sup> )
3350 (at 1500 high)	3350 (at 1500 wide)	5.03
2300 (at 3800 high)	3800 (at 2300 wide)	8.74

## CERTIFICATE No CF811

### Vetrotech Saint-Gobain International AG

#### Contraflam 30 Glass in steel framed screens for periods of 60 minutes integrity and 30 minutes insulation

The glass shall be installed into a previously tested or CERTIFIRE approved framing system (which is covered appropriately by test or assessment evidence) using pressure plate glazing, screw-fixed or clip-on retaining beads, see examples below. The glass shall be glazed into the screen as described in the table below and set on non-combustible setting blocks to determine the correct edge cover.

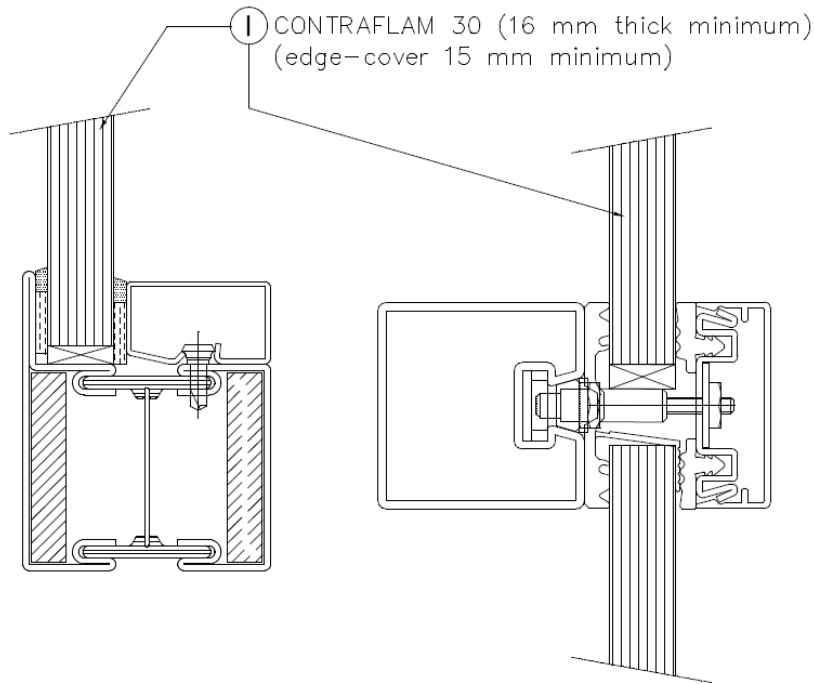

Table 36 – Maximum Permitted Glass Dimensions		
Max. Width (mm)	Max. Height (mm)	Max. Area (m <sup>2</sup> )
1500 (at 3000 high)	3000 (at 1500 wide)	4.50

## CERTIFICATE No CF811

### Vetrotech Saint-Gobain International AG

#### Contraflam 30 Glass in steel framed screens for periods of 90 minutes integrity and 30 minutes insulation

The glass shall be installed into a previously tested or CERTIFIRE approved framing system (which is covered appropriately by test or assessment evidence) using pressure plate glazing, screw-fixed or clip-on retaining beads, see examples below. The glass shall be glazed into the screen as described in the table below and set on non-combustible setting blocks to determine the correct edge cover.

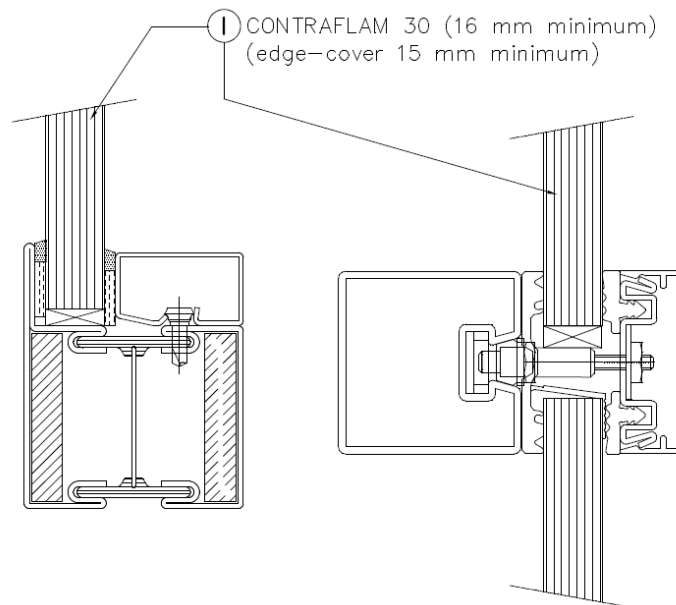

Max. Width (mm)	Max. Height (mm)	Max. Area (m <sup>2</sup> )
1500 (at 3000 high)	3000 (at 1500 wide)	4.5

**Note:** If applicable, a STADIP laminated glass used in the composition of the Contraflam unit is allowable, but on the fire side only.

## CERTIFICATE No CF811

### Vetrotech Saint-Gobain International AG

#### Contraflam 30 Glass in steel framed screens for periods of 120 minutes integrity and 30 minutes insulation

The glass shall be installed into a previously tested or CERTIFIRE approved framing system (which is covered appropriately by test or assessment evidence) using pressure plate glazing, screw-fixed or clip-on retaining beads, see examples below. The glass shall be glazed into the screen as described in the table below and set on non-combustible setting blocks to determine the correct edge cover.

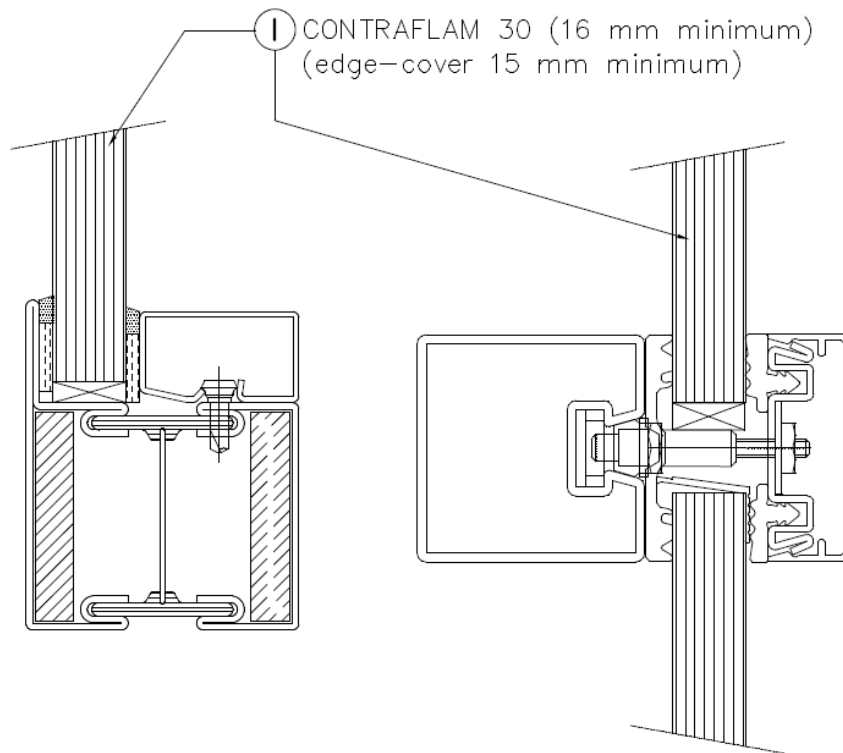

Max. Width (mm)	Max. Height (mm)	Max. Area (m <sup>2</sup> )
1500 (at 3000 high)	3000 (at 1500 wide)	4.5

**Note:** If applicable, a STADIP laminated glass used in the composition of the Contraflam unit is allowable, but on the fire side only.

## CERTIFICATE No CF811

### Vetrotech Saint-Gobain International AG

**Contraflam 30 Glass in timber framed screens for a period of 30 minutes integrity and 30 minutes insulation**

The glass shall be glazed utilising the following basic specification:

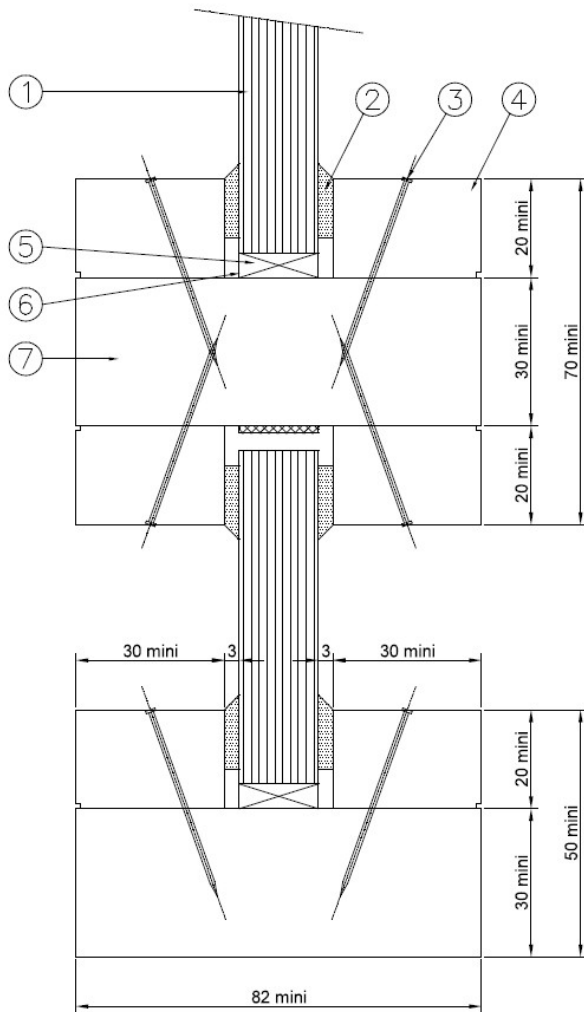

- ① CONTRAFLAM 30 (16 mm thick minimum)  
(edge-cover 15 mm)
- ② Odice Flexilodice SA Gasket 2 x 15 mm
- ③ Ø 1.8 x 40 mm long steel pins at 150 mm centres
- ④ Minimum 20 x 30 mm (h x w) timber glazing beads  
minimum density 424 kg/m<sup>3</sup>
- ⑤ Non-combustible / hardwood setting blocks  
glass thickness x 5 x 80 mm (w x h x d)  
(2 pieces per glass, on the bottom only)
- ⑥ Glazing pocket liner, Odice Flexilodice  
SA, section 2 mm x glass thickness (mm)
- ⑦ Minimum 82 x 50 mm outer timber framing section  
& 82 x 70 mm intermediate timber framing section.  
Minimum density 424 kg/m<sup>3</sup>

**Allowable glass sizes on next page.**

## CERTIFICATE No CF811

### Vetrotech Saint-Gobain International AG

**Contraflam 30 Glass in timber framed screens for a period of 30 minutes integrity and 30 minutes insulation**

The glass shall be glazed utilising the following basic specification:

Table 39 – Maximum Permitted Glass Dimensions		
Max. Width (mm)	Max. Height (mm)	Max. Area (m2)
1500 (at 3000 high)	3000 (at 1500 wide)	4.5

**Note: In the above table the Contraflam pane is limited to the 16mm thick product only.**

Table 40 – Maximum Permitted Glass Dimensions		
Max. Width (mm)	Max. Height (mm)	Max. Area (m2)
2750 (at 1500 high)	2750 (at 1500 wide)	4.125
2300 (at 3800 high)	3800 (at 2300 wide)	8.74

**Note: In the above table the Contraflam pane may be the 16mm, 18mm or 22mm thick product but may only be floor mounted. i.e. it may not be supported, from below, by a transom profile due to weight concerns.**

**Frame drawing on previous page.**

## CERTIFICATE No CF811

### Vetrotech Saint-Gobain International AG

**Contraflam 30 Glass in timber framed screens for periods of 30 minutes integrity and 30 minutes insulation**

The glass shall be glazed utilising the following basic specification:

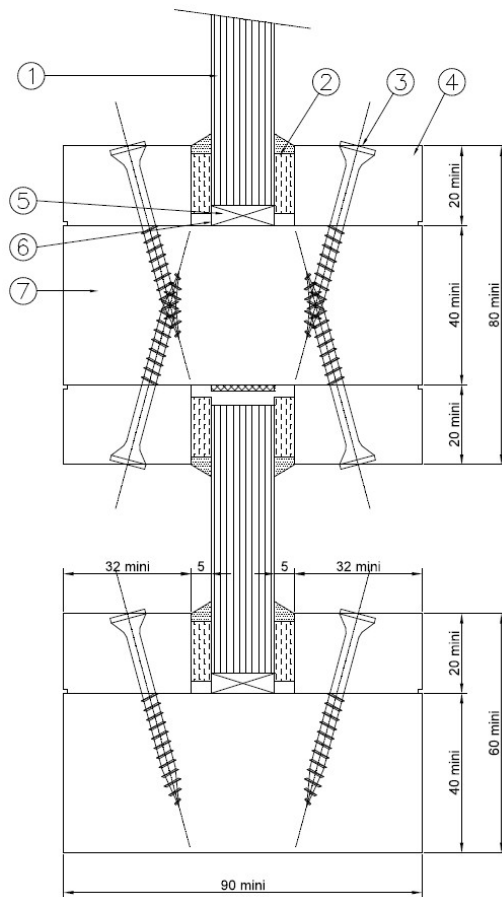

- ① CONTRAFLAM 30 (16 mm thick minimum) (edge-cover 15 mm)
- ② Fiberfrax Ceramic Tape 15 x 6 mm, topped with neutral curing silicone
- ③ 38 mm long steel screws at 300 mm centres (30° to glass)
- ④ Minimum 20 x 32 mm (h x w) timber glazing beads minimum density 680 kg/m<sup>3</sup>
- ⑤ Non-combustible / hardwood setting blocks glass thickness x 5 x 80 mm (w x h x d) (2 pieces per glass, on the bottom only)
- ⑥ Glazing pocket liner, Kuhn Flexpan 200, section 2 mm x glass thickness (mm)
- ⑦ Minimum 90 x 60 mm outer timber framing section & 90 x 80 mm intermediate timber framing section. Minimum density 680 kg/m<sup>3</sup>

**Table 41 – Maximum Permitted Glass Dimensions**

Max. Width (mm)	Max. Height (mm)	Max. Area (m <sup>2</sup> )
2750 (at 1500 high)	2750 (at 1500 wide)	4.125
2300 (at 3800 high)	3800 (at 2300 wide)	8.74

## CERTIFICATE No CF811

### Vetrotech Saint-Gobain International AG

**Contraflam 30 Glass in Aluprof MB-78EI aluminium framed screens for a period of 30 minutes integrity and 30 minutes insulation**

The glass shall be installed into the Aluprof MB-78EI aluminium framing system (which is covered appropriately by test or assessment evidence).

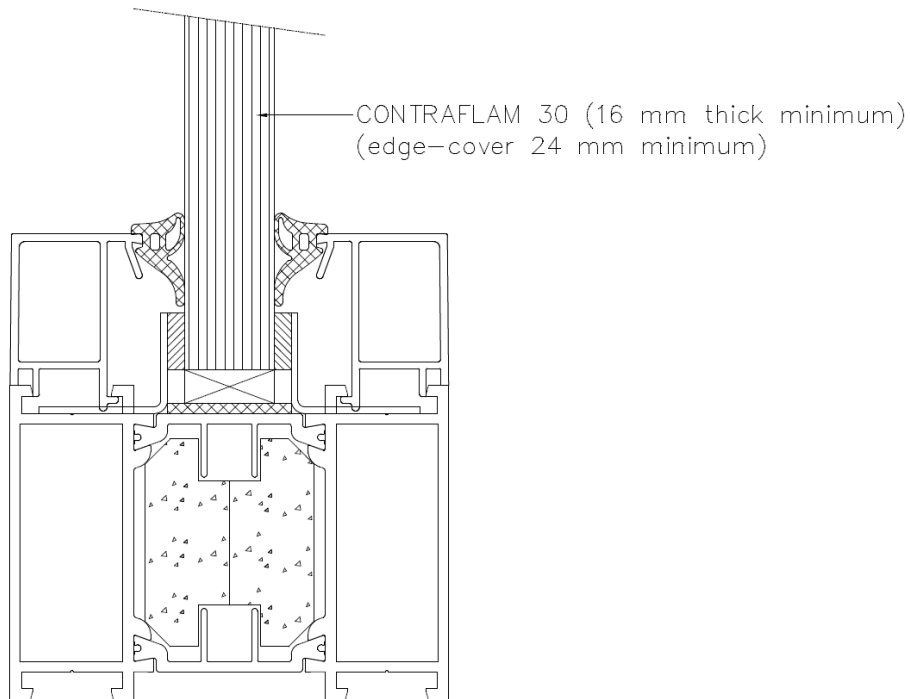

Max. Width (mm)	Max. Height (mm)	Max. Area (m2)
1875 (at 3000 high)	3750 (at 1500 wide)	5.62
3125 (at 1500 high)	1875 (at 2500 wide)	4.69

## CERTIFICATE No CF811

### Vetrotech Saint-Gobain International AG

**Contraflam 30 Glass in Reynaers CS77-FP aluminium framed screens for periods of 30 minutes integrity and 30 minutes insulation**

The glass shall be installed into the Reynaers CS77-FP aluminium framing system (which is covered appropriately by test or assessment evidence).

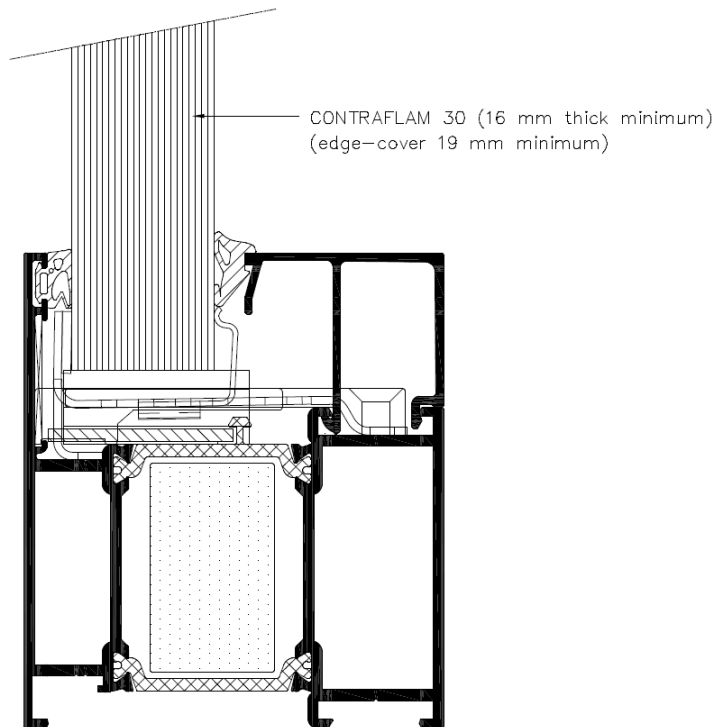

Table 43 – Maximum Permitted Glass Dimensions		
Max. Width (mm)	Max. Height (mm)	Max. Area (m2)
2203 (at 3200 high)	3616 (at 1950 wide)	7.05

## CERTIFICATE No CF811

### Vetrotech Saint-Gobain International AG

**Contraflam 30 Glass in Reynaers CW50-FP aluminium framed screens for periods of 30 minutes integrity and 30 minutes insulation**

The glass shall be installed into the Reynaers CW50-FP aluminium framing system (which is covered appropriately by test or assessment evidence).

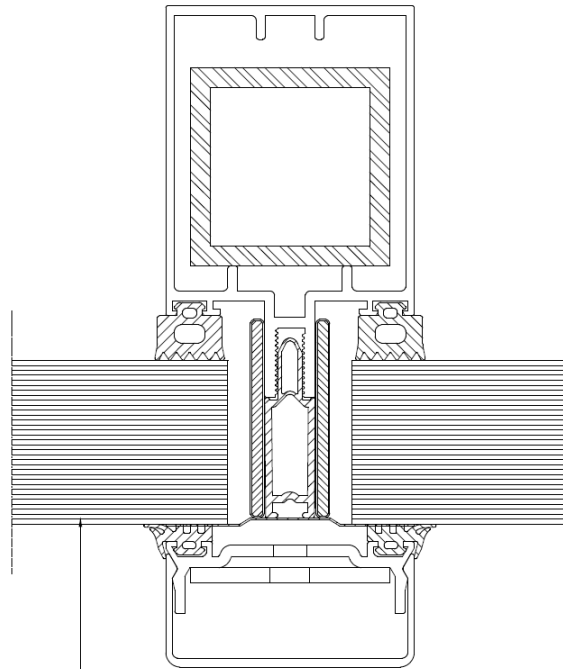

① CONTRAFLAM 30 (16 mm thick minimum)  
(edge-cover 14 mm minimum)

Table 44 – Maximum Permitted Glass Dimensions		
Max. Width (mm)	Max. Height (mm)	Max. Area (m2)
2300 (at 3339 high)	3800 (at 2021 wide)	7.68

## CERTIFICATE No CF811

### Vetrotech Saint-Gobain International AG

**Contraflam 30 Glass in Schuco ADS80 FR30 aluminium framed screens for periods of 30 minutes integrity and 30 minutes insulation**

The glass shall be installed into the Schuco ADS80 FR30 aluminium framing system (which is covered appropriately by test or assessment evidence).

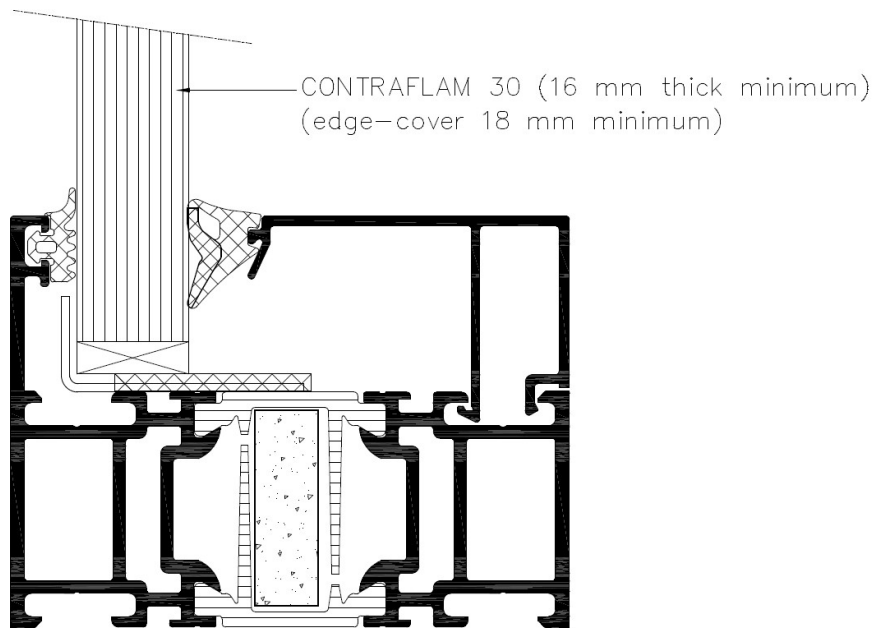

Table 45 – Maximum Permitted Glass Dimensions		
Max. Width (mm)	Max. Height (mm)	Max. Area (m2)
2502 (at 1400 high)	1442 (at 2430 wide)	3.50
1442 (at 3000 high)	3090 (at 1400 wide)	4.32

## CERTIFICATE No CF811

### Vetrotech Saint-Gobain International AG

**Contraflam 30 Glass in Schuco FW 50+ BF aluminium framed screens for periods of 30 minutes integrity and 30 minutes insulation**

The glass shall be installed into the Schuco FW 50+ BF aluminium framing system (which is covered appropriately by test or assessment evidence).

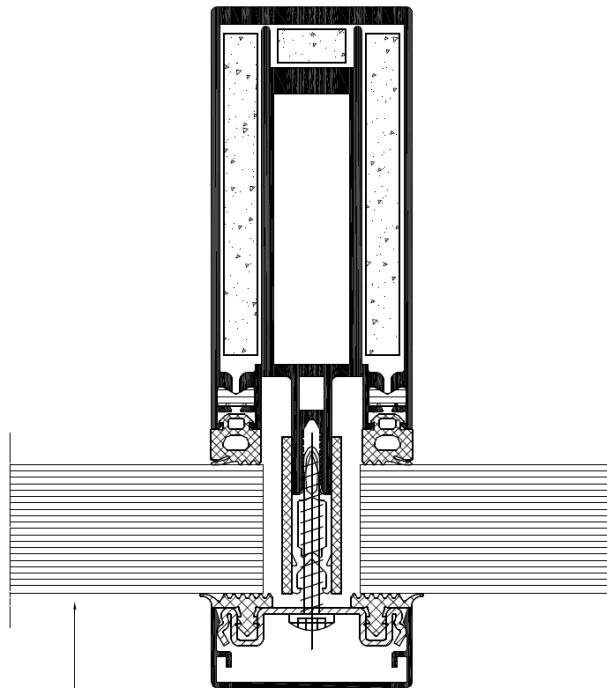

① CONTRAFLAM 30 (16 mm thick minimum)  
(edge-cover 13 mm minimum)

Table 46 – Maximum Permitted Glass Dimensions		
Max. Width (mm)	Max. Height (mm)	Max. Area (m <sup>2</sup> )
2300 (at 3800 high)	3800 (at 2300 wide)	8.74
2875 (at 2300 high)	2300 (at 2875 wide)	6.61

## CERTIFICATE No CF811

### Vetrotech Saint-Gobain International AG

**Contraflam 30 Glass in Wicona Wicstyle 77FP aluminium framed screens for periods of 30 minutes integrity and 30 minutes insulation**

The glass shall be installed into the Wicona Wicstyle 77FP aluminium framing system (which is covered appropriately by test or assessment evidence).

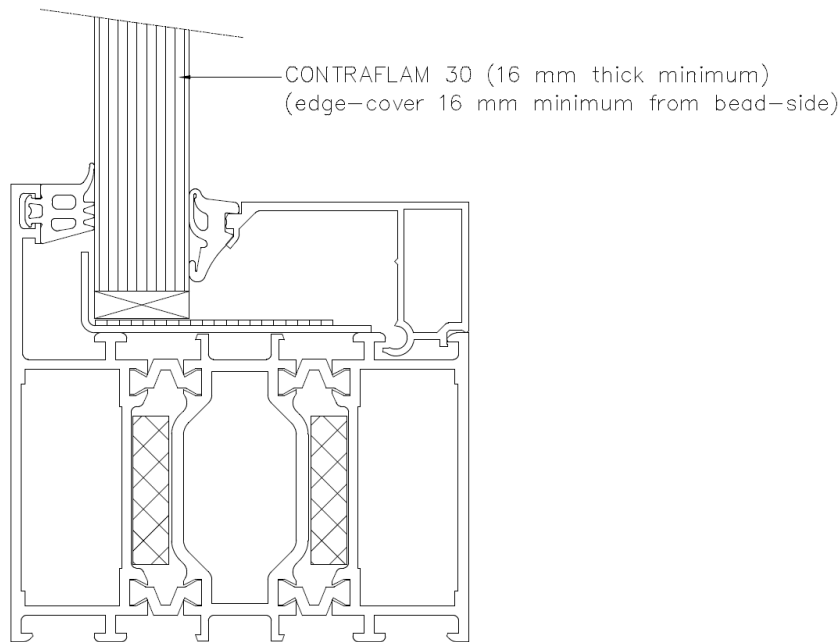

Table 47 – Maximum Permitted Glass Dimensions		
Max. Width (mm)	Max. Height (mm)	Max. Area (m2)
1802 (at 3000 high)	3600 (at 1502 wide)	5.40
2715 (at 1500 high)	1800 (at 2263 wide)	4.07

## CERTIFICATE No CF811

### Vetrotech Saint-Gobain International AG

#### Contraflam 30 Climaplus Glass in steel framed screens for periods of 30 minutes integrity and 30 minutes insulation

The glass shall be installed into a previously tested or CERTIFIRE approved framing system (which is covered appropriately by test or assessment evidence) using pressure plate glazing, screw-fixed or clip-on retaining beads, see examples below. The glass shall be glazed into the screen as described in the table below and set on non-combustible setting blocks to determine the correct edge cover.

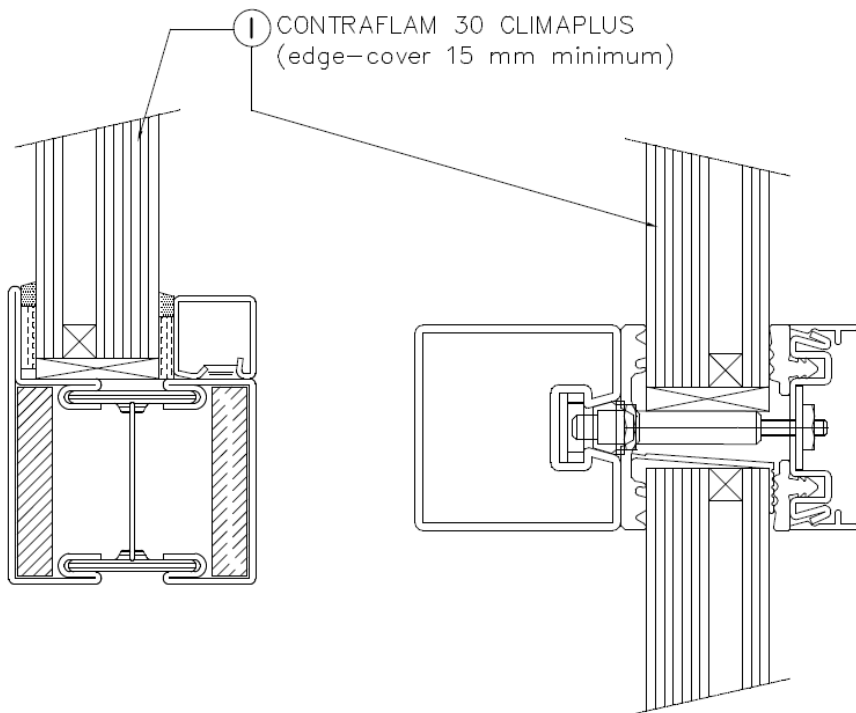

Max. Width (mm)	Max. Height (mm)	Max. Area (m <sup>2</sup> )
2300 (at 3800 high)	3800 (at 2300 wide)	8.74
3350 (at 1500 high)	3350 (at 1500 wide)	5.03

## CERTIFICATE No CF811

### Vetrotech Saint-Gobain International AG

#### Contraflam 30 Climaplus Glass in steel framed screens for periods of 60 minutes integrity and 30 minutes insulation

The glass shall be installed into a previously tested or CERTIFIRE approved framing system (which is covered appropriately by test or assessment evidence) using pressure plate glazing, screw-fixed or clip-on retaining beads, see examples below. The glass shall be glazed into the screen as described in the table below and set on non-combustible setting blocks to determine the correct edge cover.

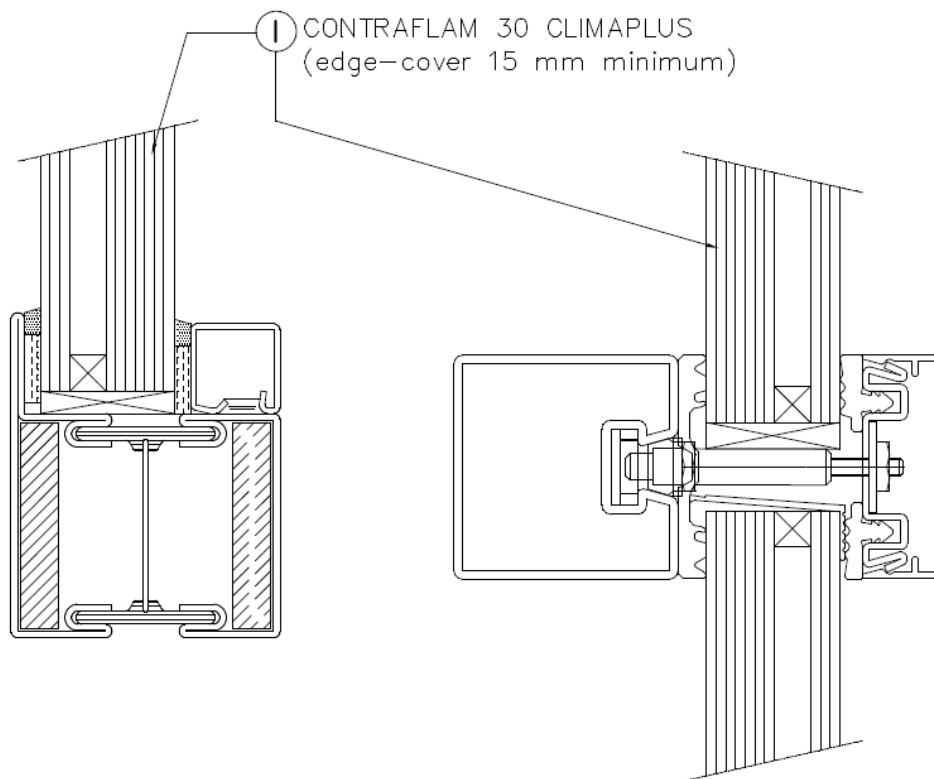

Max. Width (mm)	Max. Height (mm)	Max. Area (m <sup>2</sup> )
1300 (at 2300 high)	2300 (at 1300 wide)	2.99

## CERTIFICATE No CF811

### Vetrotech Saint-Gobain International AG

**Contraflam 30 Climaplus Glass in timber framed screens for a period of 30 minutes integrity and 30 minutes insulation**

The glass shall be glazed utilising the following basic specification:

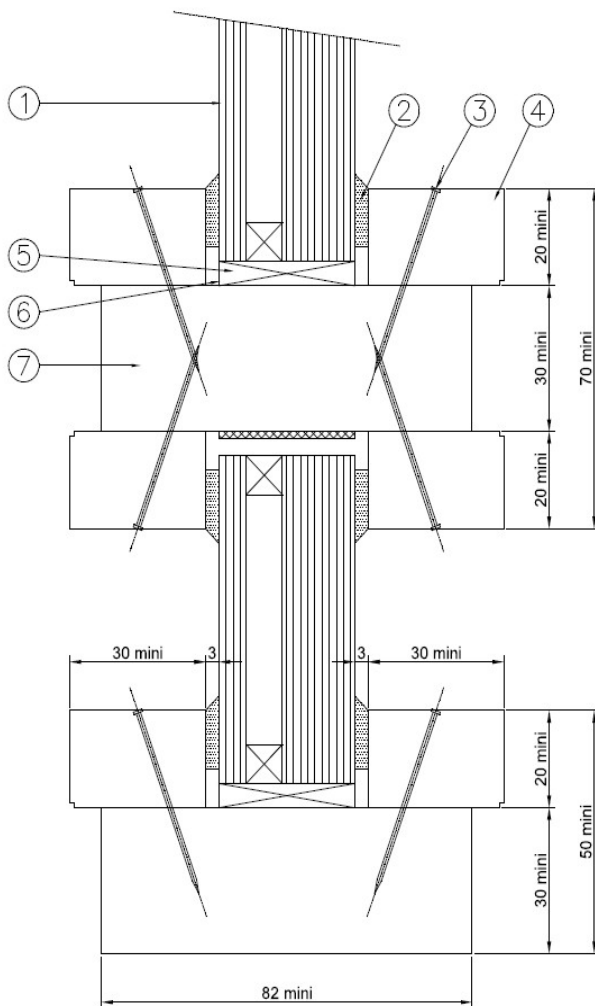

- ① CONTRAFLAM 30 CLIMAPLUS (edge-cover 15 mm)
- ② Odice Flexilodice SA Gasket 2 x 15 mm
- ③ Ø 1.8 x 40 mm long steel pins at 150 mm centres
- ④ Minimum 20 x 30 mm (h x w) timber glazing beads minimum density 424 kg/m<sup>3</sup>
- ⑤ Non-combustible / hardwood setting blocks glass thickness x 5 x 80 mm (w x h x d) (2 pieces per glass, on the bottom only)
- ⑥ Glazing pocket liner, Odice Flexilodice SA, section 2 mm x glass thickness (mm)
- ⑦ Minimum 82 x 50 mm outer timber framing section & 82 x 70 mm intermediate timber framing section. Minimum density 424 kg/m<sup>3</sup>

**Allowable glass sizes on next page.**

## CERTIFICATE No CF811 Vetrotech Saint-Gobain International AG

**Contraflam 30 Climaplus Glass in timber framed screens for a period of 30 minutes integrity and 30 minutes insulation**

The glass shall be glazed utilising the following basic specification:

Table 50 – Maximum Permitted Glass Dimensions		
Max. Width (mm)	Max. Height (mm)	Max. Area (m2)
1500 (at 3000 high)	3000 (at 1500 wide)	4.5

**Note:** In the above table the Contraflam pane is limited to the 16mm thick product only.

Table 51 – Maximum Permitted Glass Dimensions		
Max. Width (mm)	Max. Height (mm)	Max. Area (m2)
2300 (at 3800 high)	3800 (at 2300 wide)	8.74
2750 (at 1500 high)	2750 (at 1500 wide)	4.125

**Note:** In the above table the Contraflam pane may be the 16mm, 18mm or 22mm thick product but may only be floor mounted. i.e. it may not be supported, from below, by a transom profile due to weight concerns.

Frame drawing on previous page.

## CERTIFICATE No CF811

### Vetrotech Saint-Gobain International AG

**Contraflam 30 Climaplus Glass in timber framed screens for periods of 30 minutes integrity and 30 minutes insulation**

The glass shall be glazed utilising the following basic specification:

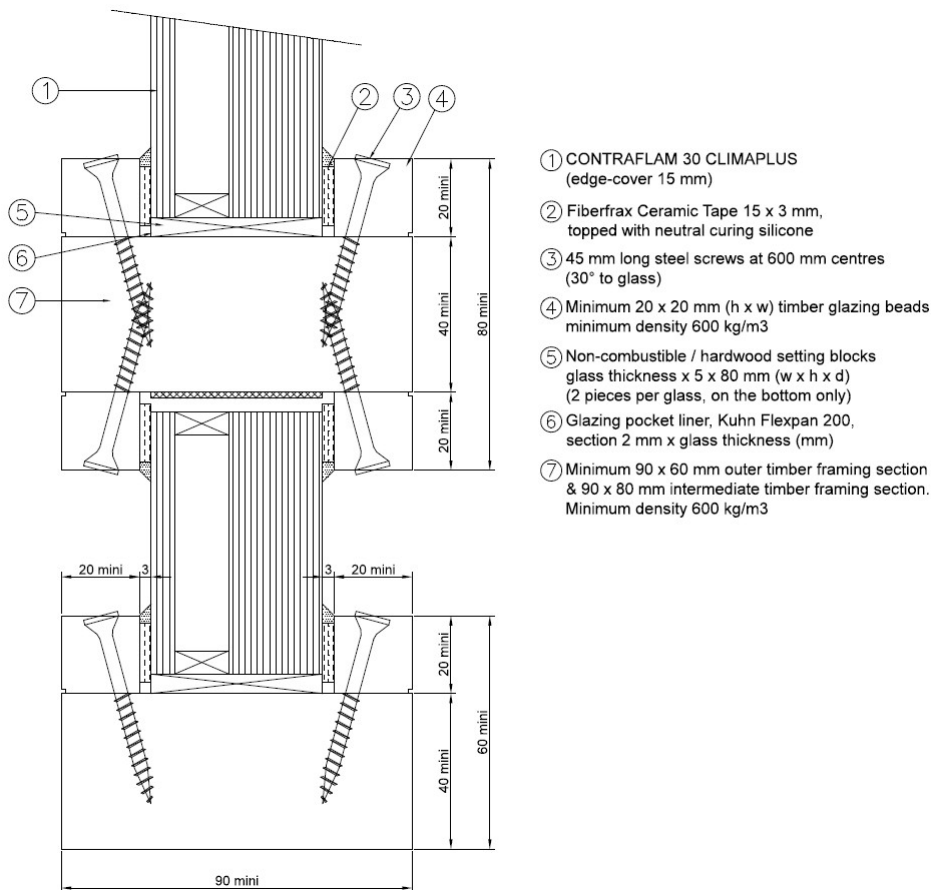

**Table 52 – Maximum Permitted Glass Dimensions**

Max. Width (mm)	Max. Height (mm)	Max. Area (m <sup>2</sup> )
2300 (at 3800 high)	3800 (at 2300 wide)	8.74
2750 (at 1500 high)	2750 (at 1500 wide)	4.125

## CERTIFICATE No CF811

### Vetrotech Saint-Gobain International AG

**Contraflam 30 Climaplust Glass in Kawneer AA100 FR aluminium framed screens for a period of 30 minutes integrity and 30 minutes insulation**

The glass shall be glazed utilising the following basic specification:

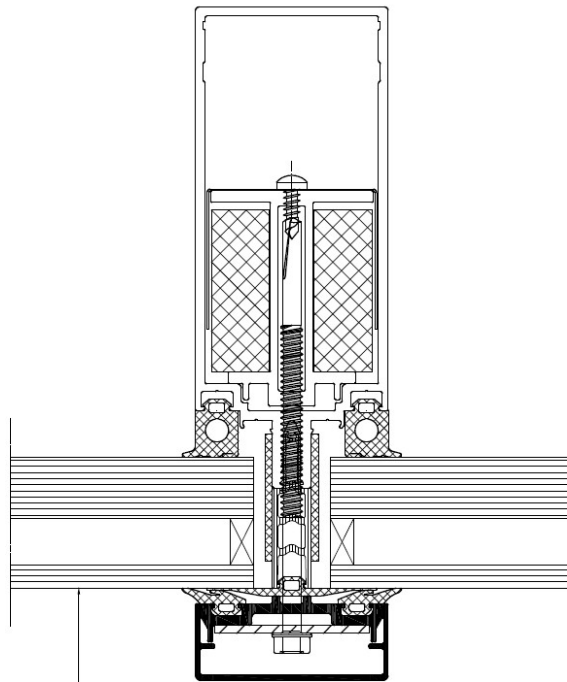

① CONTRAFLAM 30 CLIMAPLUS  
(minimum edge cover =  
15 mm vertical edges  
15 mm top edge  
13 mm bottom edge)

Table 53 – Maximum Permitted Glass Dimensions		
Max. Width (mm)	Max. Height (mm)	Max. Area (m2)
2787 (at 1403 high)	1753 (at 2230 wide)	3.91
1787 (at 2503 high)	3128 (at 1430 wide)	4.47

## CERTIFICATE No CF811

### Vetrotech Saint-Gobain International AG

**Contraflam 30 Climaplus Glass in Reynaers CS77-FP aluminium framed screens for periods of 30 minutes integrity and 30 minutes insulation**

The glass shall be installed into the Reynaers CS77-FP aluminium framing system (which is covered appropriately by test or assessment evidence).

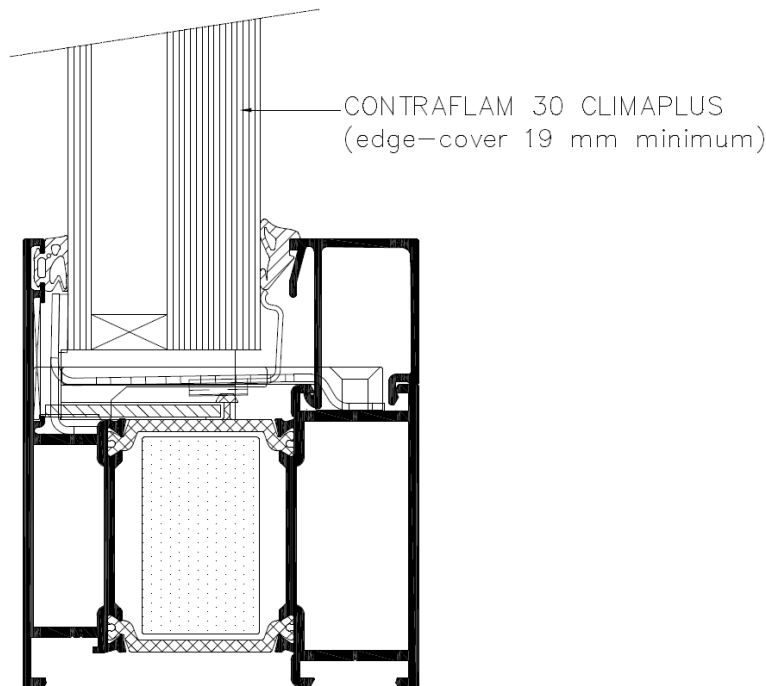

Table 54 – Maximum Permitted Glass Dimensions		
Max. Width (mm)	Max. Height (mm)	Max. Area (m2)
1017 (at 2500 high)	2825 (at 900 wide)	2.54

## CERTIFICATE No CF811

### Vetrotech Saint-Gobain International AG

**Contraflam 30 Climaplus Glass in Reynaers CW50-FP aluminium framed screens for periods of 30 minutes integrity and 30 minutes insulation**

The glass shall be installed into the Reynaers CW50-FP aluminium framing system (which is covered appropriately by test or assessment evidence).

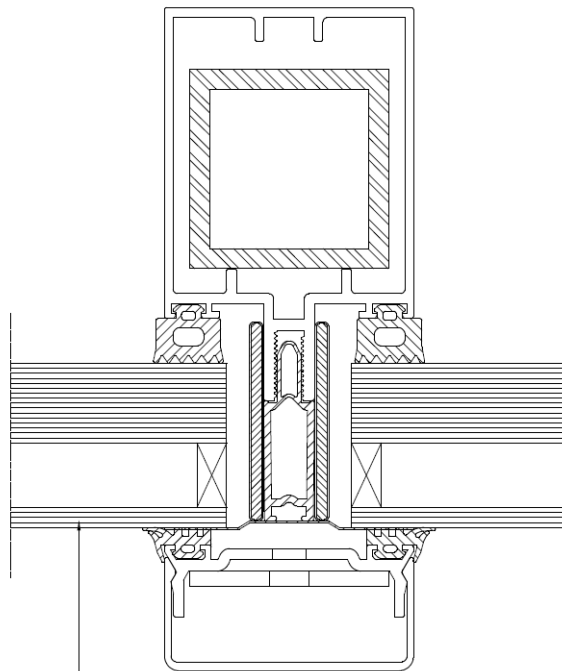

① CONTRAFLAM 30 CLIMAPLUS  
(edge-cover 14 mm minimum)

Table 55 – Maximum Permitted Glass Dimensions		
Max. Width (mm)	Max. Height (mm)	Max. Area (m <sup>2</sup> )
2300 (at 3339 high)	3800 (at 2021 wide)	7.68

## CERTIFICATE No CF811

### Vetrotech Saint-Gobain International AG

**Contraflam 30 Horizontal Climaplus Glass in Schuco FW 50+ BF aluminium framed screens, in a horizontal orientation, for periods of 30 minutes integrity and 30 minutes insulation**

The glass shall be installed into the Schüco FW 50+ BF aluminium framing system (which is covered appropriately by test or assessment evidence).

CONTRAFLAM 30 CLIMAPLUS  
(edge-cover 13 mm minimum) ①

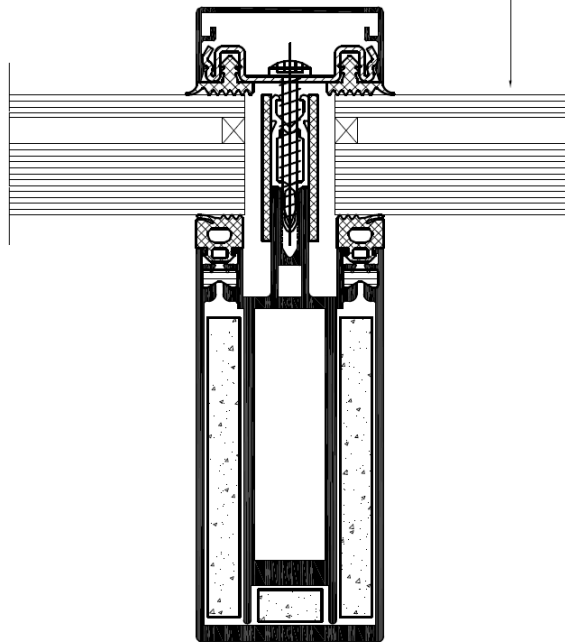

The construction may be installed between 0° and 80° (from the horizontal).

Table 56 – Maximum Permitted Glass Dimensions		
Max. Width (mm)	Max. Height (mm)	Max. Area (m2)
1500 (at 2400 high)	3000 (at 1200 wide)	3.60
2750 (at 1100 high)	1375 (at 2200 wide)	3.02

## CERTIFICATE No CF811

### Vetrotech Saint-Gobain International AG

#### Contraflam 30 Contour Glass in steel framed screens for periods of 120 minutes integrity and 30 minutes insulation

The glass shall be installed into a previously tested or CERTIFIRE approved framing system (which is covered appropriately by test or assessment evidence) using pressure plate glazing, screw-fixed or clip-on retaining beads, see examples below. The glass shall be glazed into the screen as described in the table below and set on non-combustible setting blocks to determine the correct edge cover.

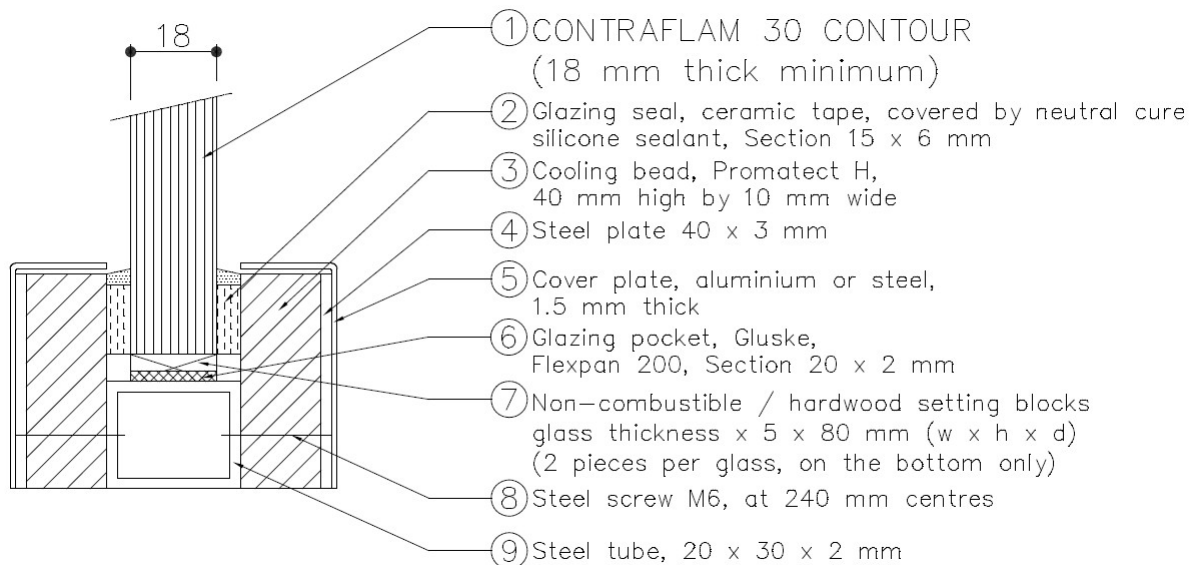

Table 57 – Maximum Permitted Glass Dimensions		
Max. Width (mm)	Max. Height (mm)	Max. Area (m <sup>2</sup> )
922 (at 1890 high)	1890 (at 922 wide)	1.74

**Note: If applicable, a STADIP laminated glass used in the composition of the Contraflam unit is allowable, but on the fire side only.**

## CERTIFICATE No CF811

### Vetrotech Saint-Gobain International AG

**Contraflam 30 Contour Glass in timber framed screens for periods of 30 minutes integrity and 30 minutes insulation**

The glass shall be glazed utilising the following basic specification:

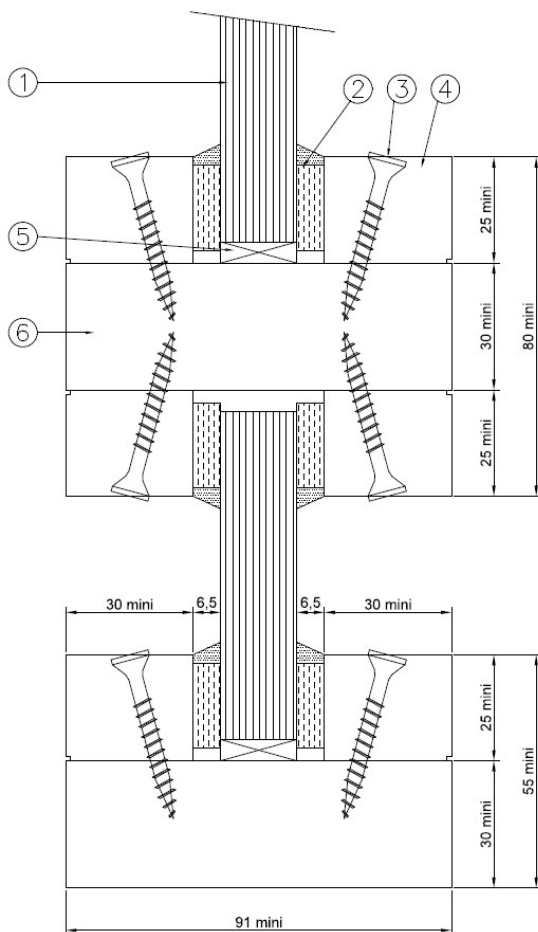

- ① CONTRAFLAM 30 CONTOUR (18 mm thick minimum)  
(minimum edge-cover =  
15 mm vertical edges  
20 mm top edge  
20 mm bottom edge)
- ② Fiberfrax Ceramic Tape 20 x 8 mm,  
topped with neutral curing silicone
- ③ 40 mm long steel screws at 200 mm centres  
(30° to glass)
- ④ Minimum 25 x 30 mm (h x w) timber glazing beads  
minimum density 600 kg/m<sup>3</sup>
- ⑤ Non-combustible / hardwood setting blocks  
glass thickness x 5 x 80 mm (w x h x d)  
(2 pieces per glass, on the bottom only)
- ⑥ Minimum 91 x 55 mm outer timber framing section  
& 91 x 55 mm intermediate timber framing section.  
Minimum density 600 kg/m<sup>3</sup>

**Table 58 – Maximum Permitted Glass Dimensions**

Max. Width (mm)	Max. Height (mm)	Max. Area (m <sup>2</sup> )
992 (at 1830 high)	1830 (at 992 wide)	1.81

## CERTIFICATE No CF811

### Vetrotech Saint-Gobain International AG

#### Contraflam 30-2 Glass in steel framed screens for periods of 30 minutes integrity and 30 minutes insulation

The glass shall be installed into a previously tested or CERTIFIRE approved framing system (which is covered appropriately by test or assessment evidence) using pressure plate glazing, screw-fixed or clip-on retaining beads, see examples below. The glass shall be glazed into the screen as described in the table below and set on non-combustible setting blocks to determine the correct edge cover.

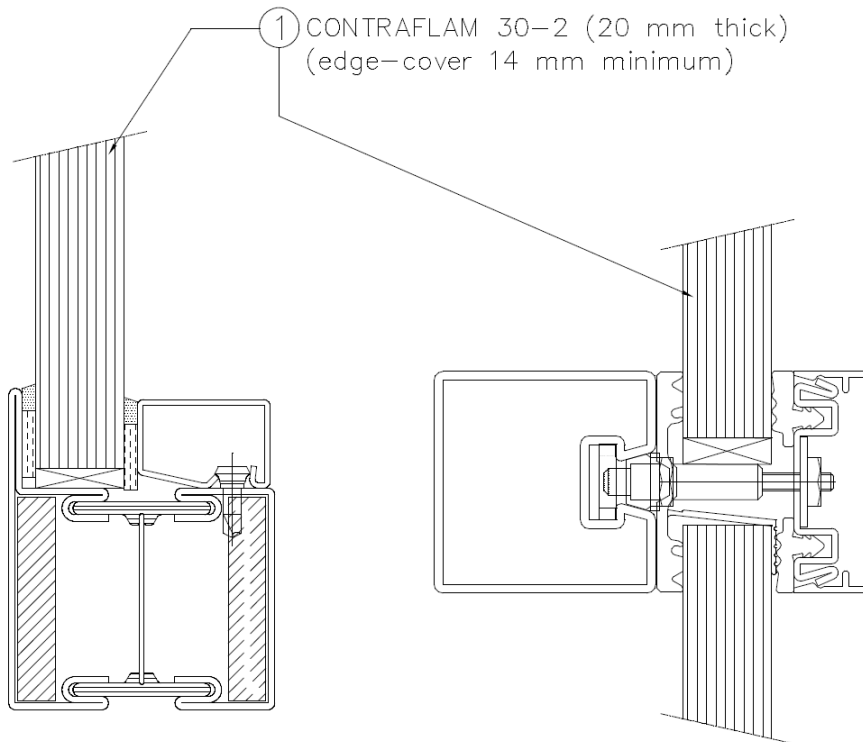

Max. Width (mm)	Max. Height (mm)	Max. Area (m <sup>2</sup> )
2300 (at 4600 high)	4600 (at 2300 wide)	10.58
2438 (at 2300 high)	2300 (at 2438 wide)	5.6

## CERTIFICATE No CF811

### Vetrotech Saint-Gobain International AG

#### Contraflam 30-2 Climaplus Glass (DGU) in steel framed screens for periods of 30 minutes integrity and 30 minutes insulation

The glass shall be installed into a previously tested or CERTIFIRE approved framing system (which is covered appropriately by test or assessment evidence) using pressure plate glazing, screw-fixed or clip-on retaining beads, see examples below. The glass shall be glazed into the screen as described in the table below and set on non-combustible setting blocks to determine the correct edge cover.

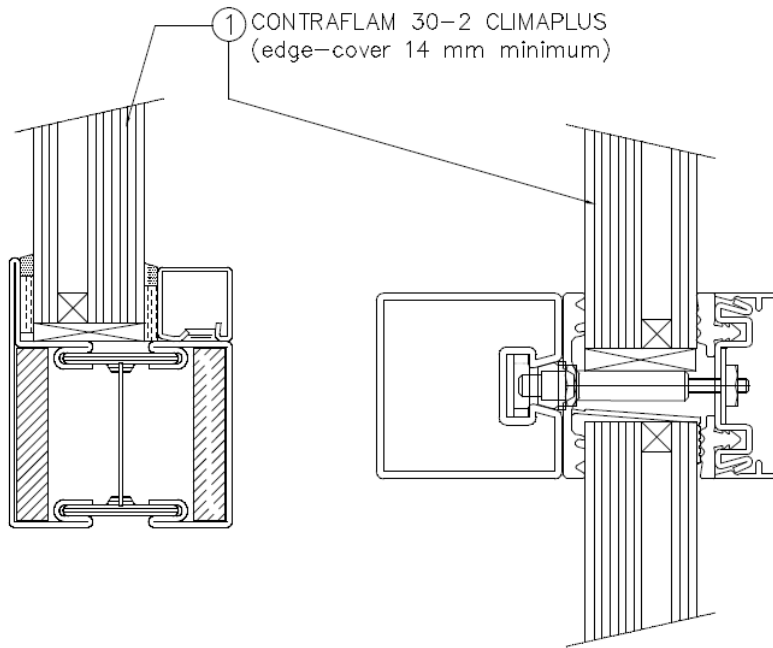

Max. Width (mm)	Max. Height (mm)	Max. Area (m <sup>2</sup> )
2300 (at 4600 high)	4600 (at 2300 wide)	10.58
2668 (at 2300 high)	2300 (at 2668 wide)	6.14

## CERTIFICATE No CF811

### Vetrotech Saint-Gobain International AG

#### Contraflam 30-2 Climatop Glass (TGU) in steel framed screens for periods of 30 minutes integrity and 30 minutes insulation

The glass shall be installed into a previously tested or CERTIFIRE approved framing system (which is covered appropriately by test or assessment evidence) using pressure plate glazing, screw-fixed or clip-on retaining beads, see examples below. The glass shall be glazed into the screen as described in the table below and set on non-combustible setting blocks to determine the correct edge cover.

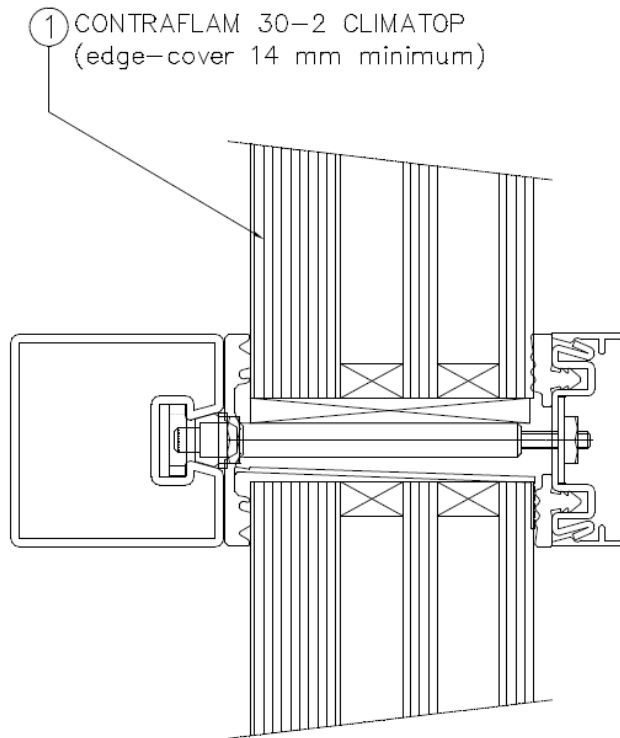

Max. Width (mm)	Max. Height (mm)	Max. Area (m <sup>2</sup> )
2300 (at 4600 high)	4600 (at 2300 wide)	10.58
2668 (at 2300 high)	2300 (at 2668 wide)	6.14

## CERTIFICATE No CF811

### Vetrotech Saint-Gobain International AG

#### Contraflam 60-3 Glass in steel framed screens for periods of 60 minutes integrity and 60 minutes insulation

The glass shall be installed into a previously tested or CERTIFIRE approved framing system (which is covered appropriately by test or assessment evidence) using pressure plate glazing, screw-fixed or clip-on retaining beads, see examples below. The glass shall be glazed into the screen as described in the table below and set on non-combustible setting blocks to determine the correct edge cover.

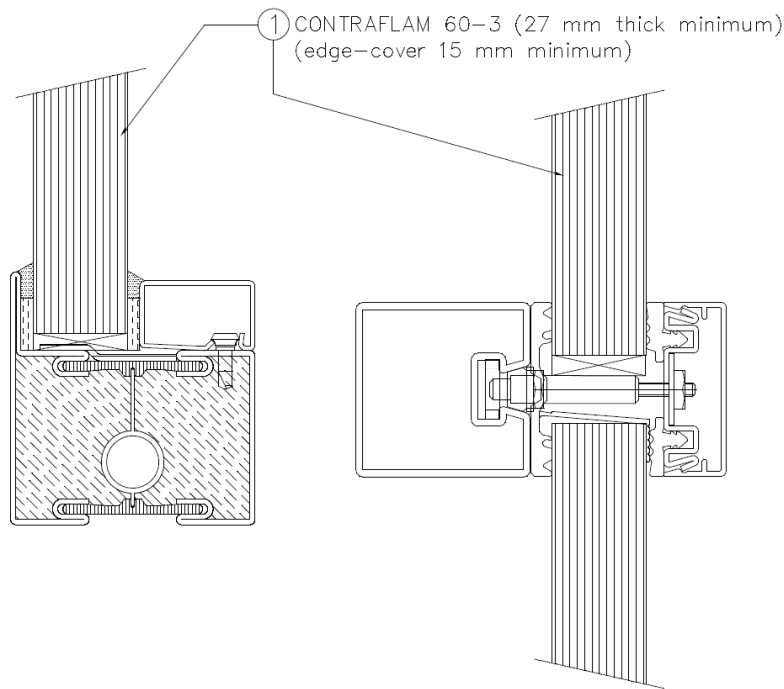

Max. Width (mm)	Max. Height (mm)	Max. Area (m <sup>2</sup> )
2300 (at 4600 high)	4600 (at 2300 wide)	10.58
2875 (at 2300 high)	2300 (at 2875 wide)	6.61

## CERTIFICATE No CF811

### Vetrotech Saint-Gobain International AG

#### Contraflam 60-3 Glass in timber framed screens for periods of 60 minutes integrity and 60 minutes insulation

The glass shall be glazed utilising the following basic specification:

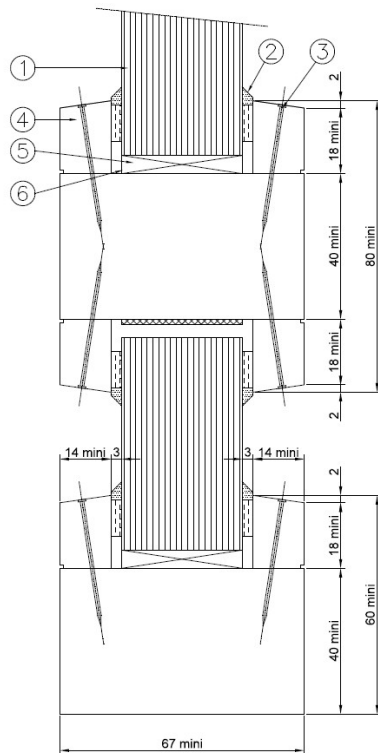

- ① CONTRAFLAM 60-3 (27 mm thick minimum) (edge-cover 15 mm)
- ② Kuhn Kerafix 2000 Tape 3 x 15 mm, topped with neutral curing silicone
- ③ Ø 1.5 x 35 mm long steel pins at 150 mm centres
- ④ Minimum 20 x 14 mm (h x w) timber glazing beads minimum density 600 kg/m<sup>3</sup>
- ⑤ Non-combustible / hardwood setting blocks glass thickness x 5 x 80 mm (w x h x d) (2 pieces per glass, on the bottom only)
- ⑥ Glazing pocket liner, Kuhn Flexpan 200, section 2 mm x glass thickness (mm)
- ⑦ Minimum 67 x 60 mm outer timber framing section & 67 x 80 mm intermediate timber framing section. Minimum density 600 kg/m<sup>3</sup>

**Table 63 – Maximum Permitted Glass Dimensions**

Max. Width (mm)	Max. Height (mm)	Max. Area (m <sup>2</sup> )
2700 (at 1400 high)	1400 (at 2700 wide)	3.78
2153 (at 3499 high)	3884 (at 1940 wide)	7.53
2300 (at 3800 high)	3800 (at 2300 wide)	8.74

## CERTIFICATE No CF811

### Vetrotech Saint-Gobain International AG

**Contraflam 60-3 Glass in Aluprof MB-78EI aluminium framed screens for periods of 60 minutes integrity and 60 minutes insulation**

The glass shall be installed into the Aluprof MB-78EI aluminium framing system (which is covered appropriately by test or assessment evidence).

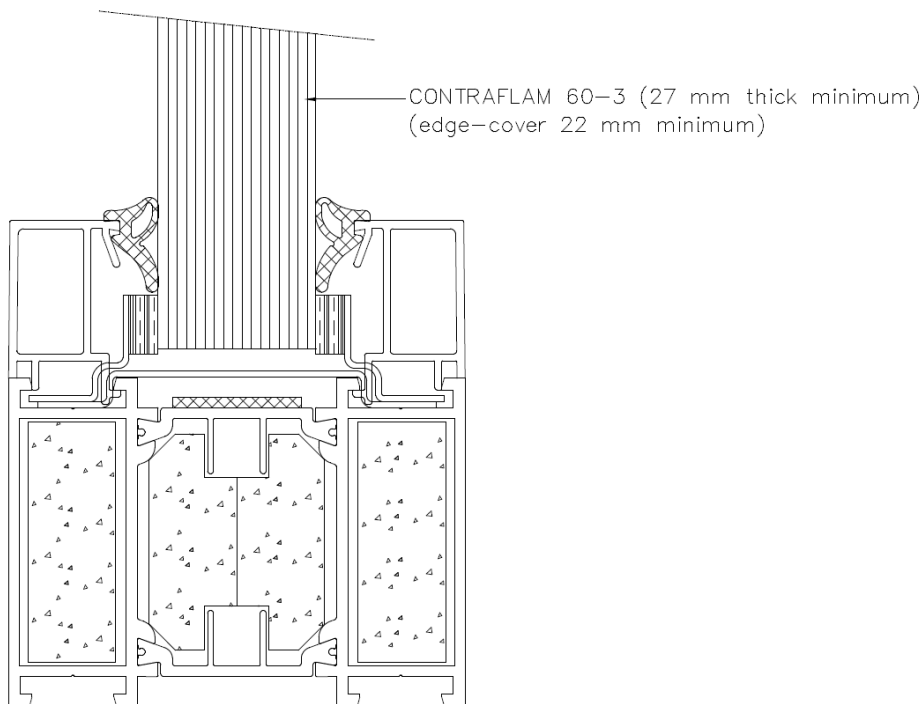

Max. Width (mm)	Max. Height (mm)	Max. Area (m2)
1620 (at 3000 high)	3240 (at 1500 wide)	4.86

## CERTIFICATE No CF811

### Vetrotech Saint-Gobain International AG

**Contraflam 60-3 Glass in Aluprof MB-SR50EI aluminium framed screens for periods of 60 minutes integrity and 60 minutes insulation**

The glass shall be installed into the Aluprof MB-SR50EI aluminium framing system (which is covered appropriately by test or assessment evidence).

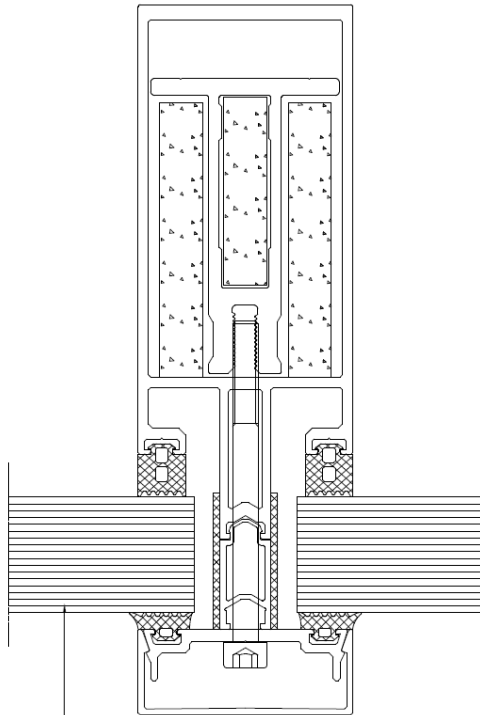

① CONTRAFLAM 60-3 (27 mm thick minimum)  
(edge-cover 13 mm minimum)

Table 65 – Maximum Permitted Glass Dimensions		
Max. Width (mm)	Max. Height (mm)	Max. Area (m <sup>2</sup> )
1665 (at 3000 high)	3330 (at 1500 wide)	4.99
2489 (at 1310 high)	1519 (at 2146 wide)	3.26

## CERTIFICATE No CF811

### Vetrotech Saint-Gobain International AG

**Contraflam 60-3 Glass in Reynaers CS77-FP aluminium framed screens for periods of 60 minutes integrity and 60 minutes insulation**

The glass shall be installed into the Reynaers CS77-FP aluminium framing system (which is covered appropriately by test or assessment evidence).

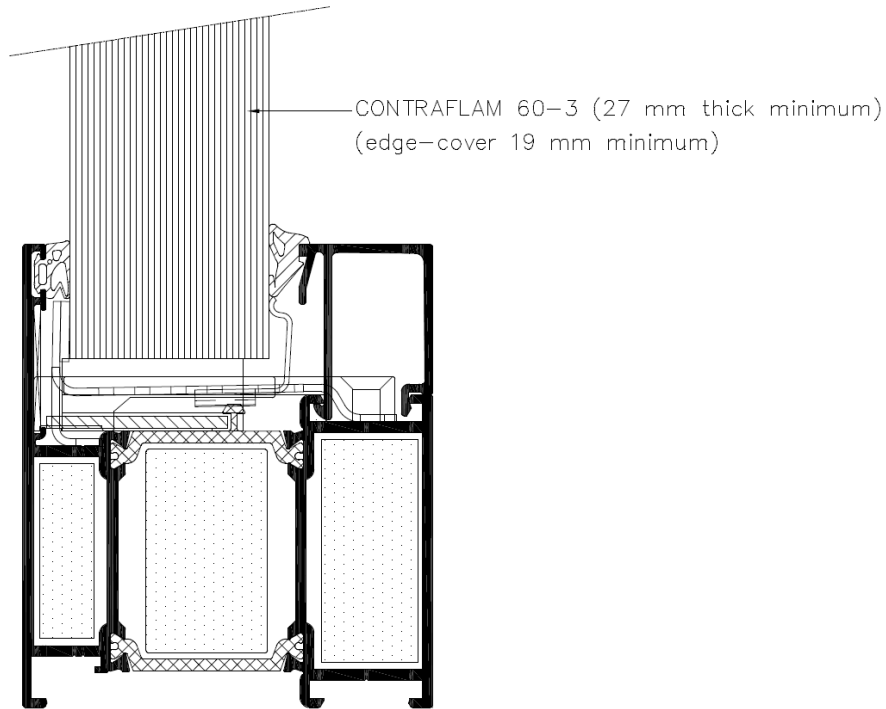

Table 66 – Maximum Permitted Glass Dimensions		
Max. Width (mm)	Max. Height (mm)	Max. Area (m2)
1620 (at 3000 high)	3240 (at 1500 wide)	4.86

## CERTIFICATE No CF811

### Vetrotech Saint-Gobain International AG

**Contraflam 60-3 Glass in Reynaers CW50-FP aluminium framed screens for periods of 60 minutes integrity and 60 minutes insulation**

The glass shall be installed into the Reynaers CW50-FP aluminium framing system (which is covered appropriately by test or assessment evidence).

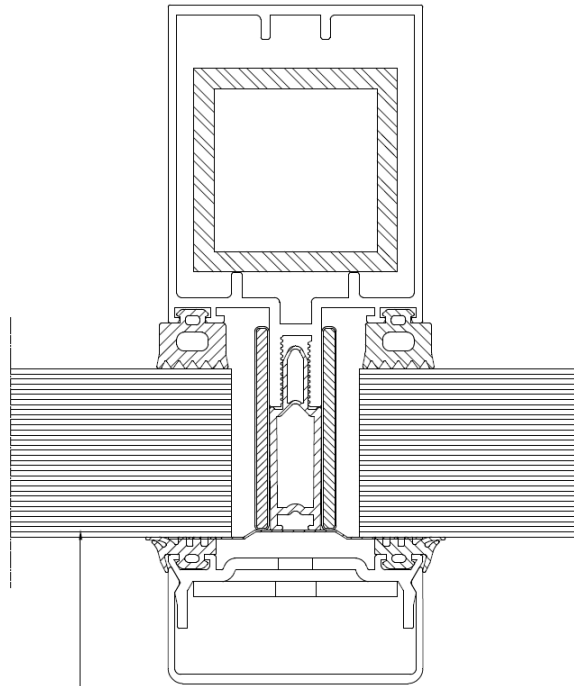

① CONTRAFLAM 60-3 (27 mm thick minimum)  
(edge-cover 14 mm minimum)

Table 67 – Maximum Permitted Glass Dimensions		
Max. Width (mm)	Max. Height (mm)	Max. Area (m2)
1590 (at 3200 high)	3392 (at 1500 wide)	5.09

## CERTIFICATE No CF811

### Vetrotech Saint-Gobain International AG

**Contraflam 60-3 Glass in Schuco ADS80 FR60 aluminium framed screen for periods of 60 minutes integrity and 60 minutes insulation**

The glass shall be installed into the Schuco ADS80 FR60 aluminium framing system (which is covered appropriately by test or assessment evidence).

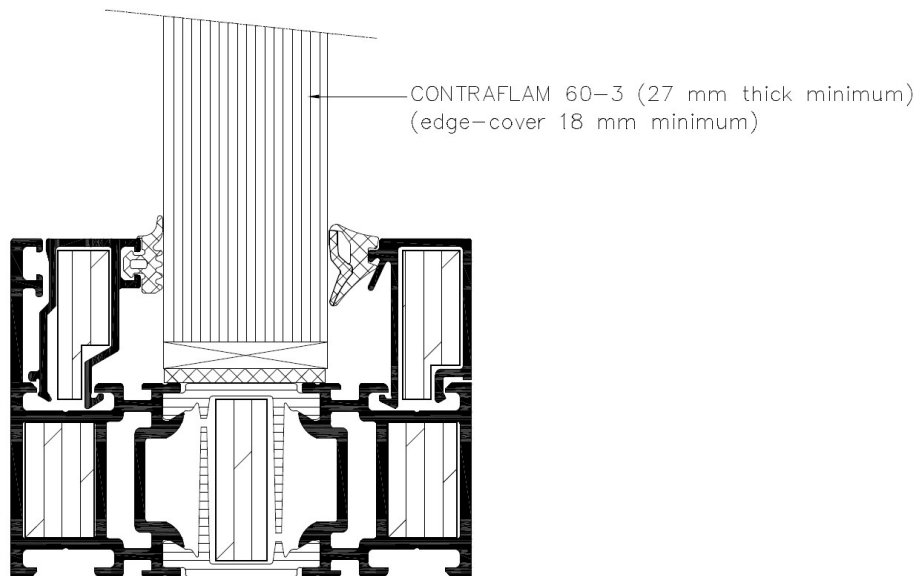

Table 68 – Maximum Permitted Glass Dimensions		
Max. Width (mm)	Max. Height (mm)	Max. Area (m2)
1436 (at 2500 high)	2700 (at 1330 wide)	3.59
2700 (at 1400 high)	1512 (at 2500 wide)	3.78

## CERTIFICATE No CF811

### Vetrotech Saint-Gobain International AG

**Contraflam 60-3 Glass in Schuco FW50+ FR60 aluminium framed screen for periods of 60 minutes integrity and 60 minutes insulation**

The glass shall be installed into the Schuco FW 50+ FR60 aluminium framing system (which is covered appropriately by test or assessment evidence).

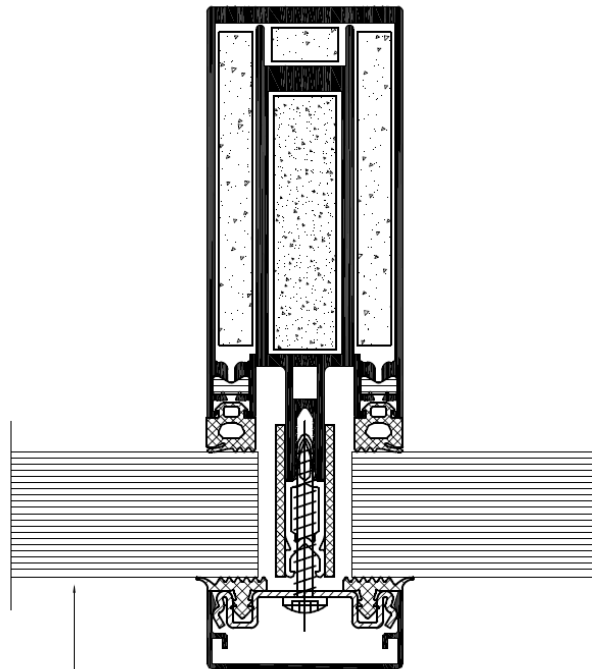

① CONTRAFLAM 60-3 (27 mm thick minimum)  
(edge-cover 13 mm minimum)

Table 69 – Maximum Permitted Glass Dimensions		
Max. Width (mm)	Max. Height (mm)	Max. Area (m2)
1845 (at 3000 high)	3690 (at 1500 wide)	5.54
2044 (at 1155 high)	1421 (at 1662 wide)	2.36

## CERTIFICATE No CF811

### Vetrotech Saint-Gobain International AG

#### Contraflam 60-3 Climaplust Glass in steel framed screens for periods of 60 minutes integrity and 60 minutes insulation

The glass shall be installed into a previously tested or CERTIFIRE approved framing system (which is covered appropriately by test or assessment evidence) using pressure plate glazing, screw-fixed or clip-on retaining beads, see examples below. The glass shall be glazed into the screen as described in the table below and set on non-combustible setting blocks to determine the correct edge cover.

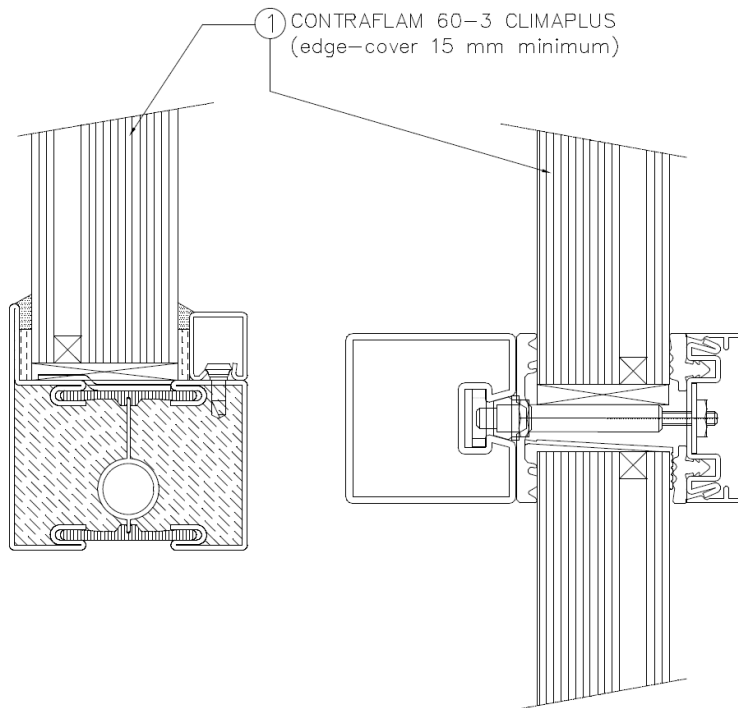

Max. Width (mm)	Max. Height (mm)	Max. Area (m <sup>2</sup> )
1500 (at 3200 high)	3200 (at 1500 wide)	4.8
2500 (at 1400 high)	1400 (at 2500 wide)	3.5

## CERTIFICATE No CF811

### Vetrotech Saint-Gobain International AG

**Contraflam 60-3 Climaplus Glass in timber framed screens for periods of 60 minutes integrity and 60 minutes insulation**

The glass shall be glazed utilising the following basic specification:

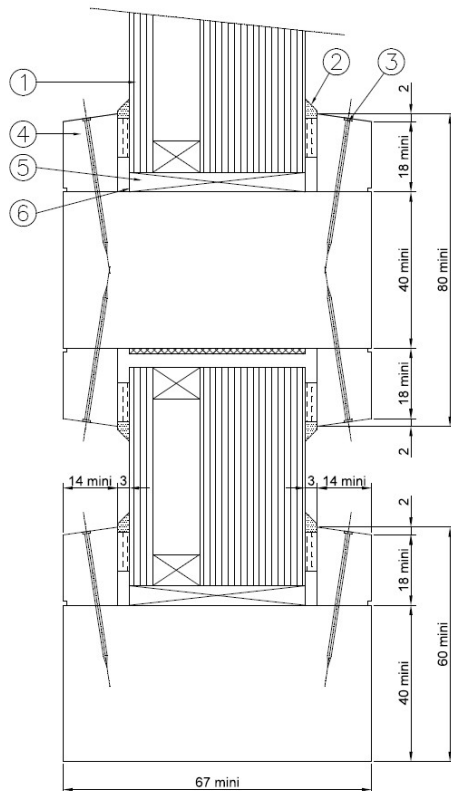

- ① CONTRAFLAM 60-3 CLIMAPLUS (edge-cover 15 mm)
- ② Kuhn Kerafix 2000 Tape 3 x 15 mm, topped with neutral curing silicone
- ③ Ø 1.5 x 35 mm long steel pins at 150 mm centres
- ④ Minimum 20 x 14 mm (h x w) timber glazing beads minimum density 600 kg/m<sup>3</sup>
- ⑤ Non-combustible / hardwood setting blocks glass thickness x 5 x 80 mm (w x h x d) (2 pieces per glass, on the bottom only)
- ⑥ Glazing pocket liner, Kuhn Flexpan 200, section 2 mm x glass thickness (mm)
- ⑦ Minimum 71 x 60 mm outer timber framing section & 71 x 80 mm intermediate timber framing section. Minimum density 600 kg/m<sup>3</sup>

Max. Width (mm)	Max. Height (mm)	Max. Area (m <sup>2</sup> )
1500 (at 3200 high)	3200 (at 1500 wide)	4.8
2500 (at 1400 high)	1400 (at 2500 wide)	3.5

## CERTIFICATE No CF811

### Vetrotech Saint-Gobain International AG

**Contraflam 60-3 Climaplus Glass in Aluprof MB-SR50EI aluminium framed screens for periods of 60 minutes integrity and 60 minutes insulation**

The glass shall be installed into the Aluprof MB-SR50EI aluminium framing system (which is covered appropriately by test or assessment evidence).

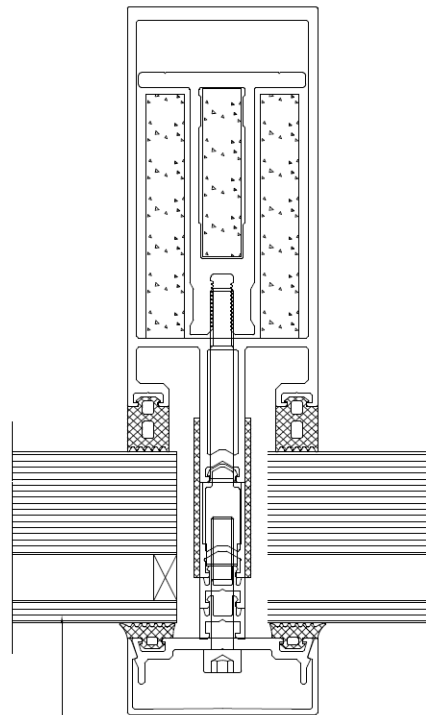

① CONTRAFLAM 60-3 CLIMAPLUS  
(edge-cover 13 mm minimum)

Table 72 – Maximum Permitted Glass Dimensions		
Max. Width (mm)	Max. Height (mm)	Max. Area (m2)
1500 (at 3200 high)	3200 (at 1500 wide)	4.8
1887 (at 1200 high)	1332 (at 1700 wide)	2.26

## CERTIFICATE No CF811

### Vetrotech Saint-Gobain International AG

**Contraflam 60-3 Climaplust Glass in Kawneer AA100FR aluminium framed screens for periods of 60 minutes integrity and 60 minutes insulation**

The glass shall be installed into the Kawneer AA100 FR aluminium framing system (which is covered appropriately by test or assessment evidence).

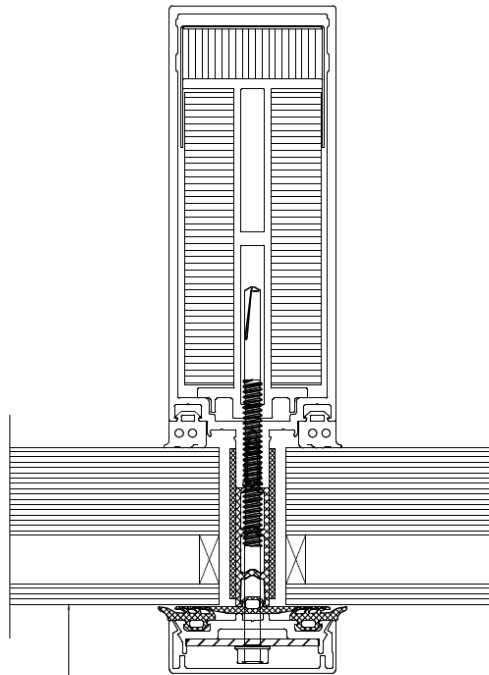

① CONTRAFLAM 60-3 CLIMAPLUS  
(minimum edge cover =  
15 mm vertical edges  
15 mm top edge  
13 mm bottom edge)

Table 73 – Maximum Permitted Glass Dimensions		
Max. Width (mm)	Max. Height (mm)	Max. Area (m2)
1480 (at 2978 high)	2978 (at 1480 wide)	4.40

## CERTIFICATE No CF811

### Vetrotech Saint-Gobain International AG

**Contraflam 60-3 Climaplust Glass in Reynaers CS77-FP aluminium framed screens for periods of 60 minutes integrity and 60 minutes insulation**

The glass shall be installed into the Reynaers CS77-FP aluminium framing system (which is covered appropriately by test or assessment evidence).

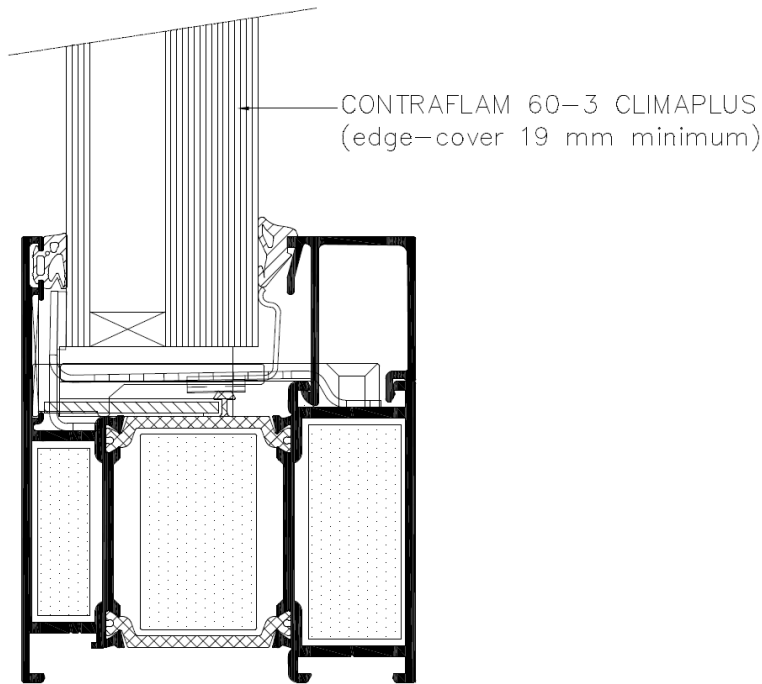

Table 74 – Maximum Permitted Glass Dimensions		
Max. Width (mm)	Max. Height (mm)	Max. Area (m2)
1500 (at 2700 high)	2700 (at 1500 wide)	4.05

## CERTIFICATE No CF811

### Vetrotech Saint-Gobain International AG

**Contraflam 60-3 Climaplus Glass in Reynaers CW50-FP aluminium framed screens for periods of 60 minutes integrity and 60 minutes insulation**

The glass shall be installed into the Reynaers CW50-FP aluminium framing system (which is covered appropriately by test or assessment evidence).

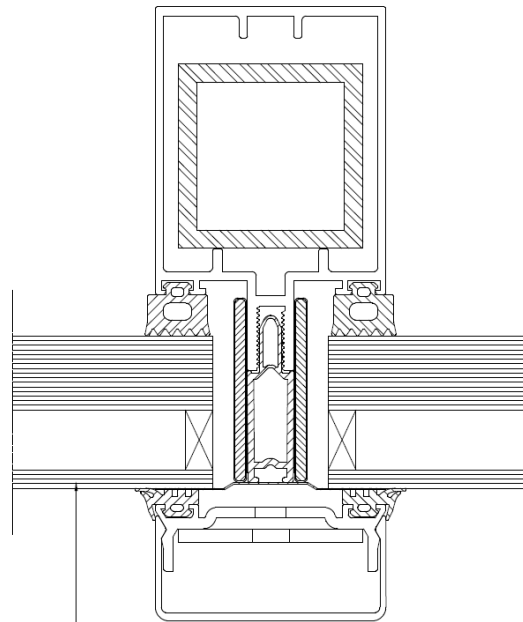

① CONTRAFLAM 60-3 CLIMAPLUS  
(edge-cover 14 mm minimum)

Table 75 – Maximum Permitted Glass Dimensions		
Max. Width (mm)	Max. Height (mm)	Max. Area (m2)
1500 (at 3200 high)	3200 (at 1500 wide)	4.8

## CERTIFICATE No CF811

### Vetrotech Saint-Gobain International AG

**Contraflam 60-3 Climaplus Glass in Schuco ADS80 FR60 aluminium framed screens for periods of 60 minutes integrity and 60 minutes insulation**

The glass shall be installed into the Schuco ADS80 FR60 aluminium framing system (which is covered appropriately by test or assessment evidence).

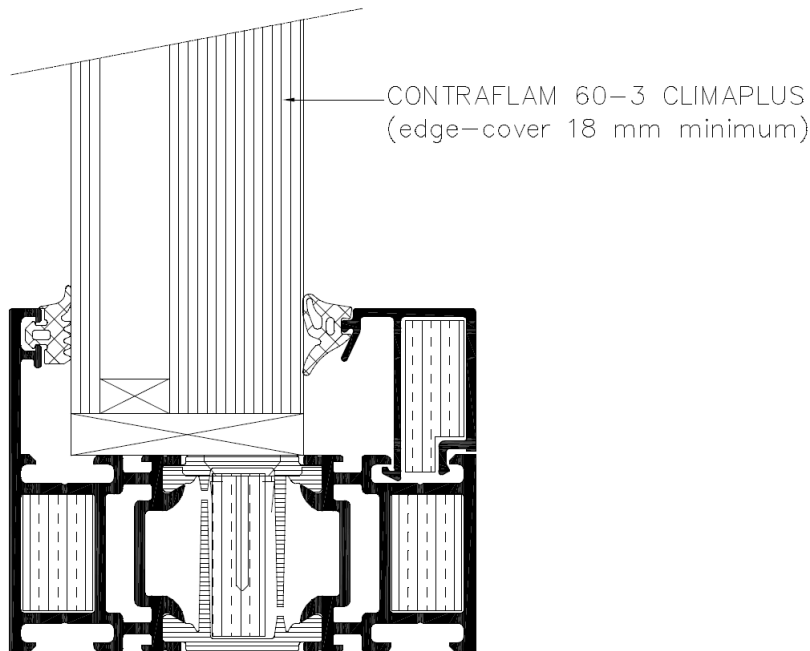

Max. Width (mm)	Max. Height (mm)	Max. Area (m <sup>2</sup> )
1330 (at 2500 high)	2500 (at 1330 wide)	3.33
2500 (at 1400 high)	1400 (at 2500 wide)	3.5

## CERTIFICATE No CF811

### Vetrotech Saint-Gobain International AG

**Contraflam 60-3 Climaplus Glass in Schuco FW 50+ FR60 aluminium framed screens for periods of 60 minutes integrity and 60 minutes insulation**

The glass shall be installed into the Schuco FW50+ FR60 aluminium framing system (which is covered appropriately by test or assessment evidence).

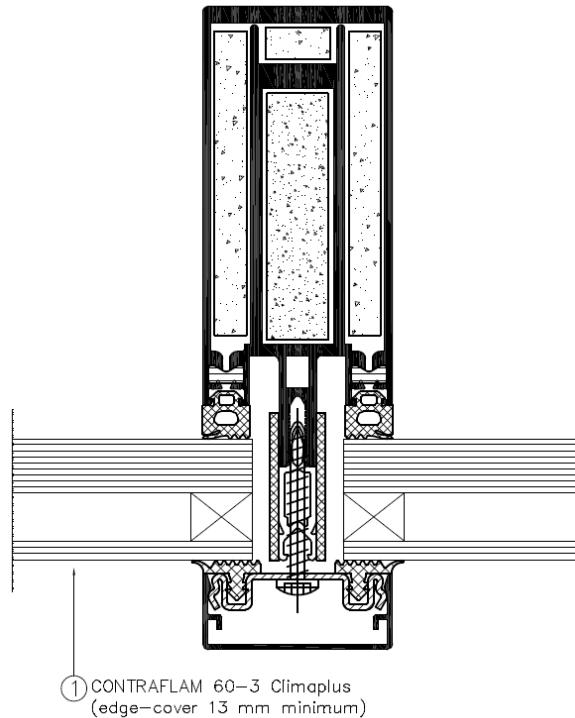

Table 77 – Maximum Permitted Glass Dimensions		
Max. Width (mm)	Max. Height (mm)	Max. Area (m2)
1500 (at 3200 high)	3200 (at 1500 wide)	4.8
2153 (at 1155 high)	1444 (at 1722 wide)	2.49

## CERTIFICATE No CF811

### Vetrotech Saint-Gobain International AG

#### Contraflam 90-4 Glass in steel framed screens for periods of 90 minutes integrity and 90 minutes insulation

The glass shall be installed into a previously tested or CERTIFIRE approved framing system (which is covered appropriately by test or assessment evidence) using pressure plate glazing, screw-fixed or clip-on retaining beads, see examples below. The glass shall be glazed into the screen as described in the table below and set on non-combustible setting blocks to determine the correct edge cover.

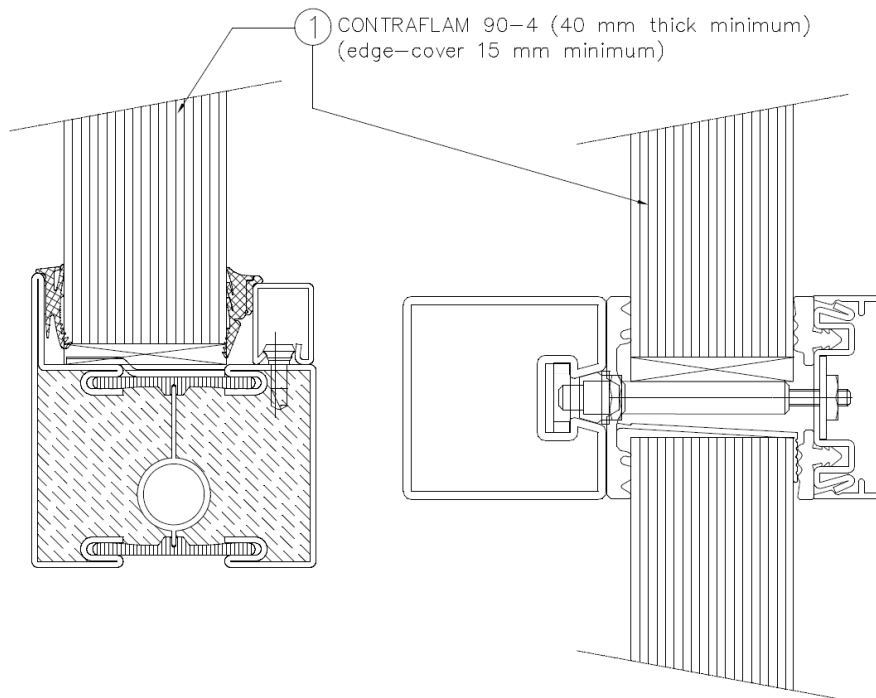

Max. Width (mm)	Max. Height (mm)	Max. Area (m <sup>2</sup> )
1500 (at 3000 high)	3000 (at 1500 wide)	4.50
1710 (at 3000 high)	3420 (at 1500 wide)	5.13

**Note: the lower set of dimensions in the above table apply to fixed lights only. The upper set of dimensions apply to glazed screens.**

## CERTIFICATE No CF811

### Vetrotech Saint-Gobain International AG

#### Contraflam 90-4 Climaplus Glass in steel framed screens for periods of 90 minutes integrity and 90 minutes insulation

The glass shall be installed into a previously tested or CERTIFIRE approved framing system (which is covered appropriately by test or assessment evidence) using pressure plate glazing, screw-fixed or clip-on retaining beads, see examples below. The glass shall be glazed into the screen as described in the table below and set on non-combustible setting blocks to determine the correct edge cover.

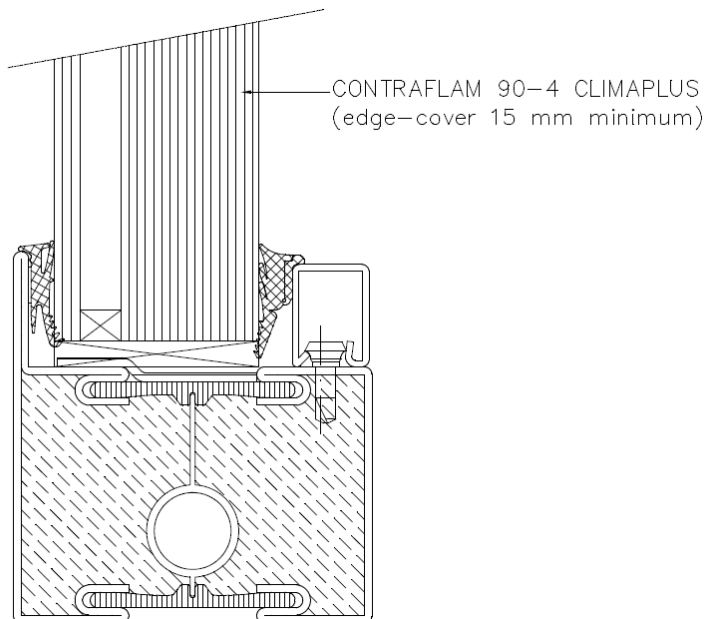

Max. Width (mm)	Max. Height (mm)	Max. Area (m <sup>2</sup> )
1500 (at 3000 high)	3000 (at 1500 wide)	4.50
1710 (at 3000 high)	3420 (at 1500 wide)	5.13

**Note: the lower set of dimensions in the above table apply to fixed lights only. The upper set of dimensions apply to glazed screens.**

## CERTIFICATE No CF811

### Vetrotech Saint-Gobain International AG

#### Contraflam 120-5 Glass in steel framed screens for periods of 120 minutes integrity and 120 minutes insulation

The glass shall be installed into a previously tested or CERTIFIRE approved framing system (which is covered appropriately by test or assessment evidence) using pressure plate glazing, screw-fixed or clip-on retaining beads, see examples below. The glass shall be glazed into the screen as described in the table below and set on non-combustible setting blocks to determine the correct edge cover.

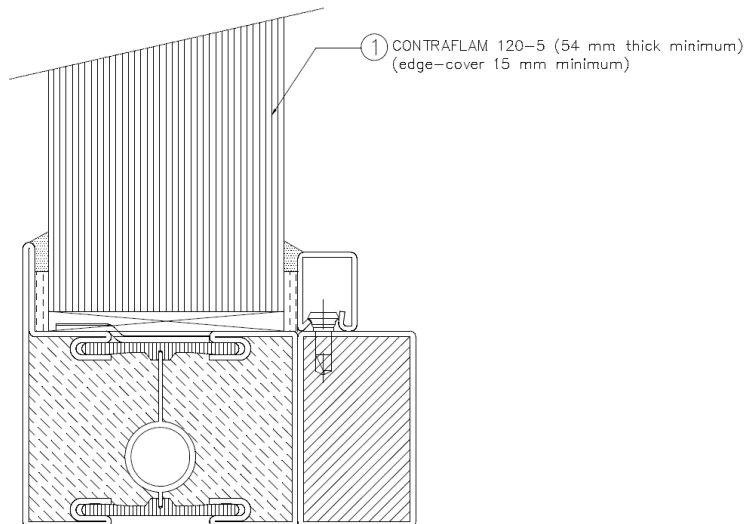

Table 80 – Maximum Permitted Glass Dimensions		
Max. Width (mm)	Max. Height (mm)	Max. Area (m2)
1800 (at 3500 high)	3500 (at 1800 wide)	6.3

## CERTIFICATE No CF811

### Vetrotech Saint-Gobain International AG

**Contraflam 120-5 Climaplus in steel framed screens for periods of 120 minutes integrity and 120 minutes insulation**

The glass shall be installed into a previously tested or CERTIFIRE approved framing system (which is covered appropriately by test or assessment evidence) using pressure plate glazing, screw-fixed or clip-on retaining beads, see examples below. The glass shall be glazed into the screen as described in the table below and set on non-combustible setting blocks to determine the correct edge cover.

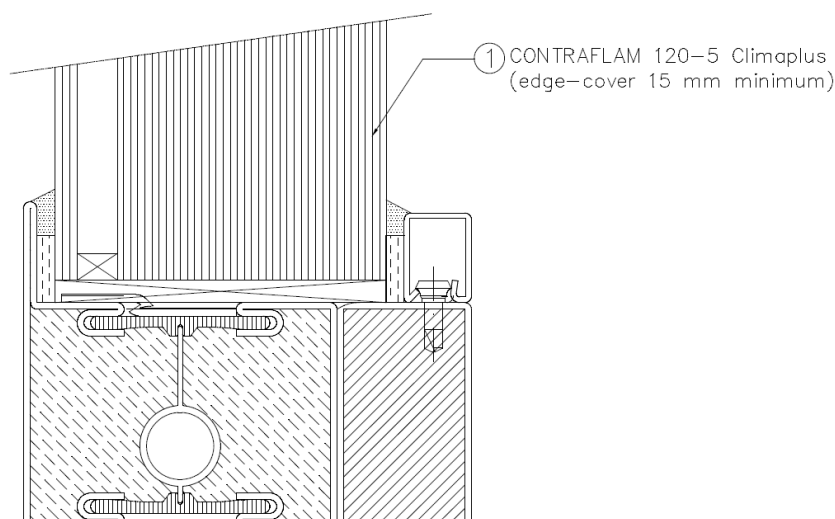

**Table 81 – Maximum Permitted Glass Dimensions**

Max. Width (mm)	Max. Height (mm)	Max. Area (m2)
1500 (at 3000 high)	3000 (at 1500 wide)	4.50

## CERTIFICATE No CF811

### Vetrotech Saint-Gobain International AG

#### Contraflam 120-6 Glass in steel framed screens for periods of 120 minutes integrity and 120 minutes insulation

The glass shall be installed into a previously tested or CERTIFIRE approved framing system (which is covered appropriately by test or assessment evidence) using pressure plate glazing, screw-fixed or clip-on retaining beads, see examples below. The glass shall be glazed into the screen as described in the table below and set on non-combustible setting blocks to determine the correct edge cover.

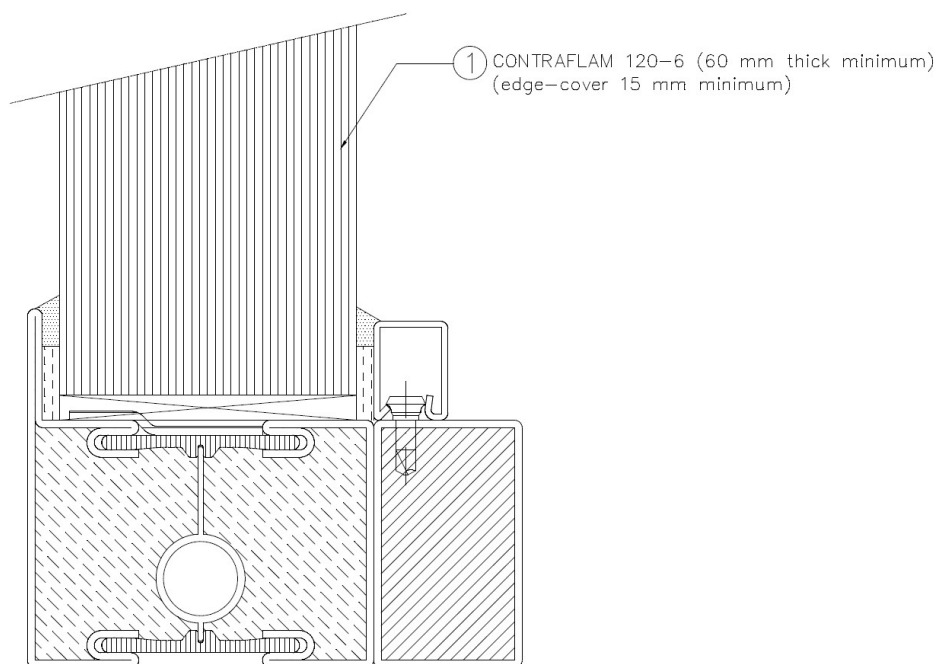

Table 82 – Maximum Permitted Glass Dimensions		
Max. Width (mm)	Max. Height (mm)	Max. Area (m <sup>2</sup> )
1500 (at 3000 high)	3000 (at 1500 wide)	4.5
2975 (at 1500 high)	1500 (at 2975 wide)	4.46

## CERTIFICATE No CF811

### Vetrotech Saint-Gobain International AG

#### Contraflam 120-6 Climaplust Glass in steel framed screens for periods of 120 minutes integrity and 120 minutes insulation

The glass shall be installed into a previously tested or CERTIFIRE approved framing system (which is covered appropriately by test or assessment evidence) using pressure plate glazing, screw-fixed or clip-on retaining beads, see examples below. The glass shall be glazed into the screen as described in the table below and set on non-combustible setting blocks to determine the correct edge cover.

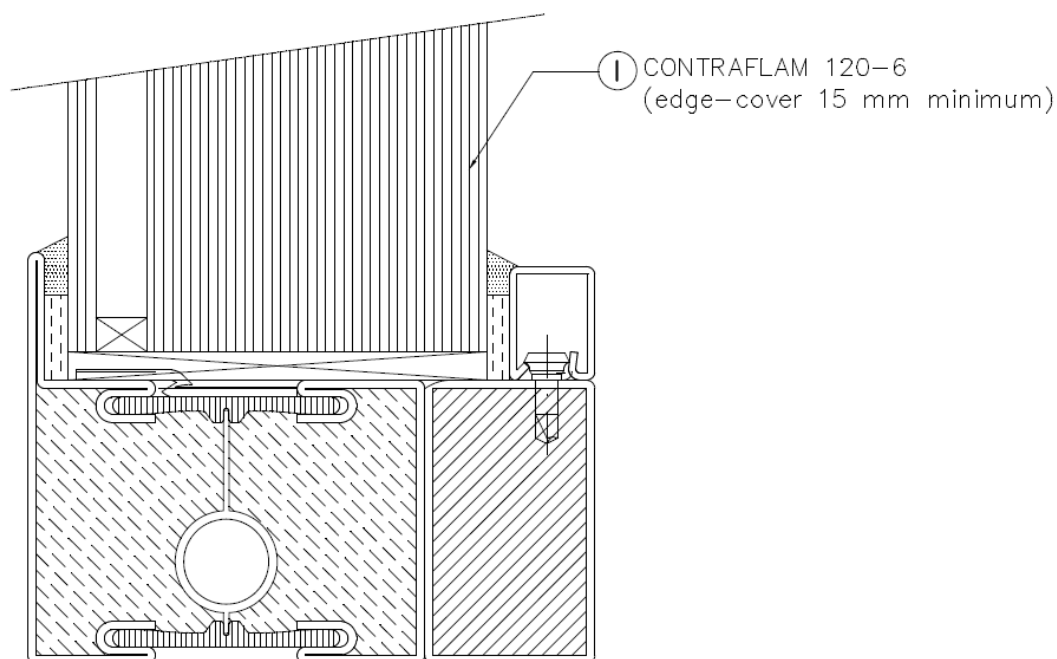

**Table 83 – Maximum Permitted Glass Dimensions**

Max. Width (mm)	Max. Height (mm)	Max. Area (m <sup>2</sup> )
1500 (at 3000 high)	3000 (at 1500 wide)	4.5

## CERTIFICATE No CF811

### Vetrotech Saint-Gobain International AG

#### Contraflam Structure Lite 30 Glass (20mm) in butt jointed steel framed screens for periods of 30 minutes integrity

The glass shall be installed into a previously tested or CERTIFIRE approved framing system (which is covered appropriately by test or assessment evidence) using pressure plate glazing, screw-fixed or clip-on retaining beads, see examples below. The glass shall be glazed into the screen as described in the table below and set on non-combustible setting blocks to determine the correct edge cover.

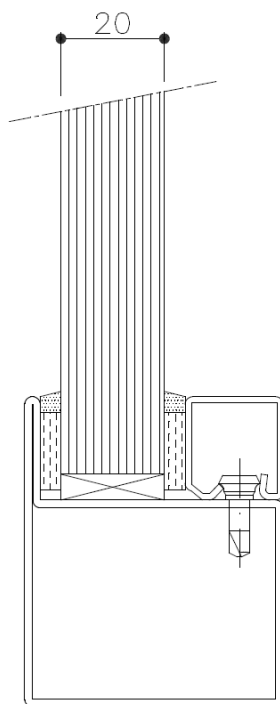

Joints between adjacent panes should be 4 mm wide and sealed with 2 pieces of 2 x 8 mm wide Kerafix FXL 200 intumescent strips and top sealed with Dow Corning 'DC 895' sealant.

Table 84 – Maximum Permitted Glass Dimensions		
Max. Width (mm)	Max. Height (mm)	Max. Area (m <sup>2</sup> )
1400 (at 3000 high)	3000 (at 1400 wide)	4.20

## CERTIFICATE No CF811

### Vetrotech Saint-Gobain International AG

#### Contraflam Structure Lite 30 Glass (20mm) in butt jointed timber framed screens for periods of 30 minutes integrity

The glass shall be glazed utilising the following basic specification:

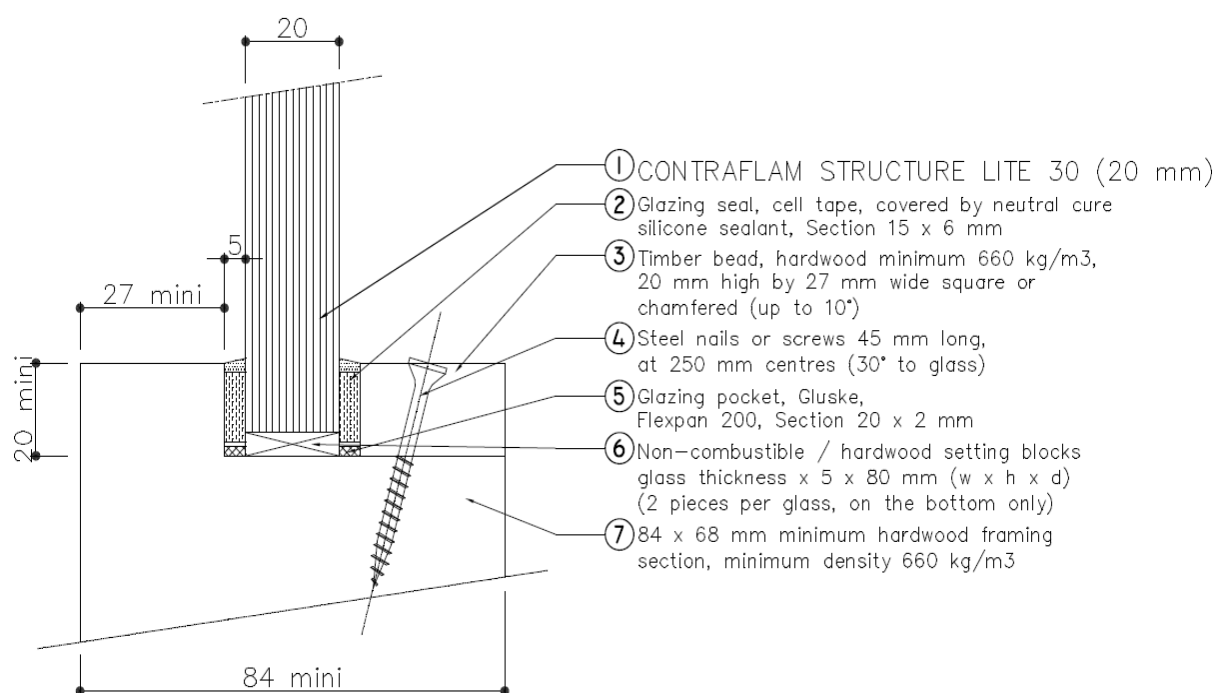

Joints between adjacent panes should be 4 mm wide and sealed with 2 pieces of 2 x 8 mm wide Kerafix FXL 200 intumescent strips and top sealed with Dow Corning 'DC 895' sealant.

Max. Width (mm)	Max. Height (mm)	Max. Area (m <sup>2</sup> )
1400 (at 3000 high)	3000 (at 1400 wide)	4.20

## CERTIFICATE No CF811

### Vetrotech Saint-Gobain International AG

#### Contraflam Structure Lite 30 Glass

#### Installation Instruction

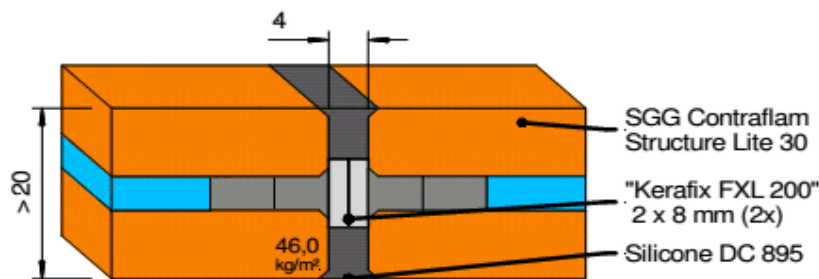

- **Clean the glass edges to be sealed**
  - remove excess polysulphide by razor blade / steel wool "00"
  - clean glass edge with: white spiritus or Dow Corning R41 (do not use other cleaning agents or solvents!)
- **Stick „Kerafix FXL 200“ on vertical glass edges**  
make sure it is centered!
- **Install glass panes and adjust to parallel position**  
glasses can be adjusted to parallel position by some continuous pressure in direction of the glass surfaces
- **Inject silicone "Dow Corning 895" into the joint, remove excessive material and smooth the joint as usual**

## CERTIFICATE No CF811

### Vetrotech Saint-Gobain International AG

#### Contraflam Structure Lite 60 (20 mm) Glass in butt jointed steel framed screens for periods of 60 minutes integrity

The glass shall be installed into a previously tested or CERTIFIRE approved framing system (which is covered appropriately by test or assessment evidence) using pressure plate glazing, screw-fixed or clip-on retaining beads, see examples below. The glass shall be glazed into the screen as described in the table below and set on non-combustible setting blocks to determine the correct edge cover.

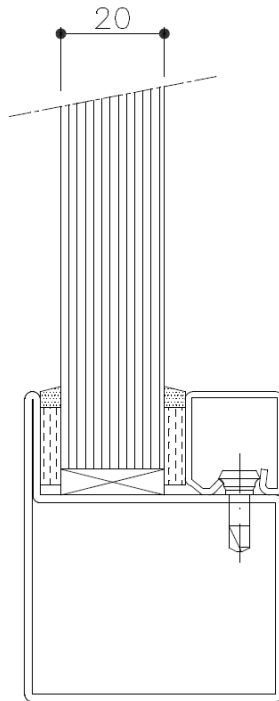

Joints between adjacent panes should be 4 mm wide and sealed with 2 pieces of 2 x 8 mm wide Kerafix FXL 200 intumescent strips and top sealed with Dow Corning 'DC 895' sealant.

Table 86 – Maximum Permitted Glass Dimensions		
Max. Width (mm)	Max. Height (mm)	Max. Area (m <sup>2</sup> )
1375 (at 2500 high)	2500 (at 1375 wide)	3.44

**Note: Use of the SGG STADIP laminated glass is prohibited i.e. 20mm thick only.**

## CERTIFICATE No CF811

### Vetrotech Saint-Gobain International AG

**Contraflam Structure Lite 60 Glass (20 mm) in butt jointed timber framed screens for periods of 60 minutes integrity**

The glass shall be glazed utilising the following basic specification:

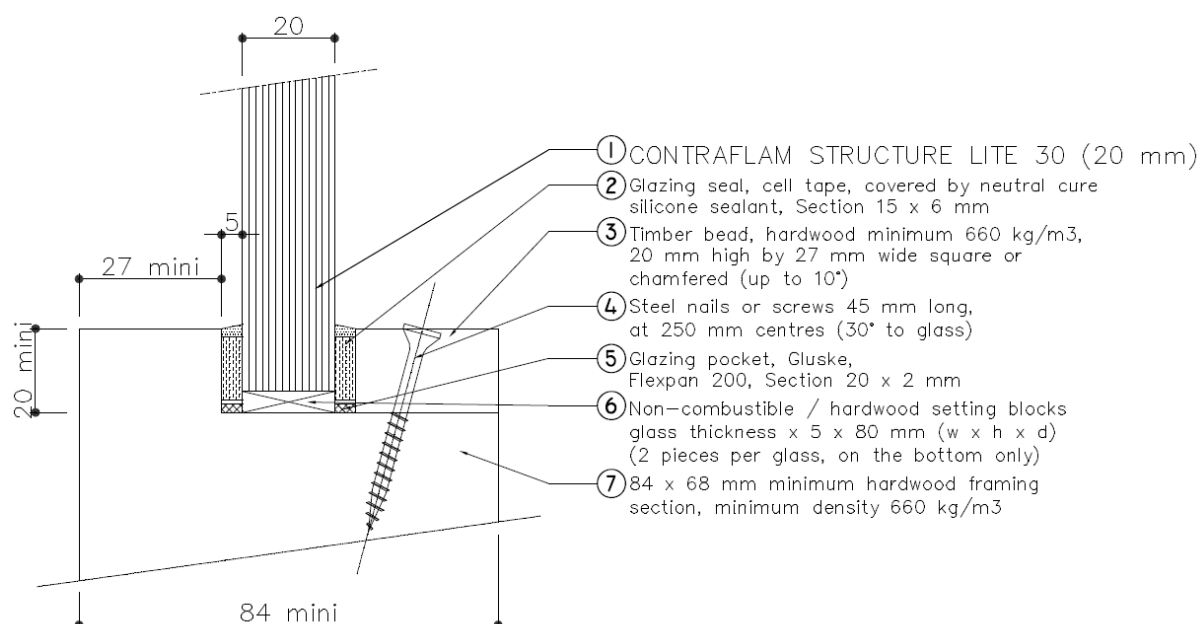

Joints between adjacent panes should be 4 mm wide and sealed with 2 pieces of 2 x 8 mm wide Kerafix FXL 200 intumescent strips and top sealed with Dow Corning 'DC 895' sealant.

Max. Width (mm)	Max. Height (mm)	Max. Area (m <sup>2</sup> )
1375 (at 2500 high)	2500 (at 1375 wide)	3.44

**Note: Use of the SGG STADIP laminated glass is prohibited i.e. 20mm thick only.**

## CERTIFICATE No CF811

### Vetrotech Saint-Gobain International AG

#### Contraflam Structure Lite 60 Glass

#### Installation Instruction

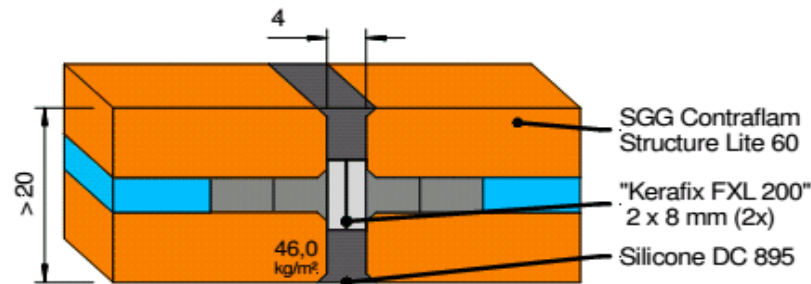

- **Clean the glass edges to be sealed**
  - remove excess polysulphide by razor blade / steel wool "00"
  - clean glass edge with: white spiritus or Dow Corning R41 (do not use other cleaning agents or solvents!)
- **Stick „Kerafix FXL 200“ on vertical glass edges**  
make sure it is centered!
- **Install glass panes and adjust to parallel position**  
glasses can be adjusted to parallel position by some continuous pressure in direction of the glass surfaces
- **Inject silicone "Dow Corning 895" into the joint, remove excessive material and smooth the joint as usual**

## CERTIFICATE No CF811

### Vetrotech Saint-Gobain International AG

**Contraflam Structure 30 Glass (23 mm) in butt jointed steel framed screens for periods of 30 minutes integrity and insulation**

The glass shall be installed into a previously tested or CERTIFIRE approved framing system (which is covered appropriately by test or assessment evidence) using pressure plate glazing, screw-fixed or clip-on retaining beads, see examples below. The glass shall be glazed into the screen as described in the table below and set on non-combustible setting blocks to determine the correct edge cover.

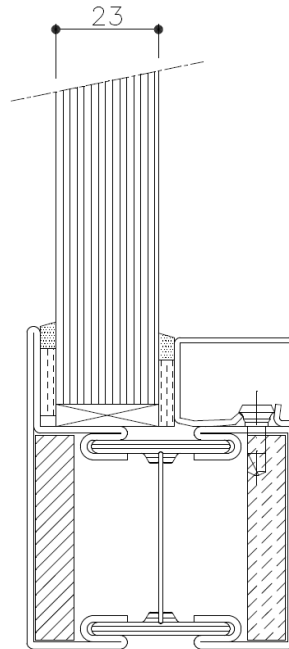

Joints between adjacent panes should be 3 mm wide and sealed with 1 piece of 2 x 13 mm wide 'Palusol T' intumescent strip or 4 mm wide with 2 pieces of 2 x 13mm wide FXL 200 intumescent strips both options top sealed with 'DC895 sealant'.

<b>Table 88 – Maximum Permitted Glass Dimensions</b>		
<b>Max. Width (mm)</b>	<b>Max. Height (mm)</b>	<b>Max. Area (m<sup>2</sup>)</b>
1500 (at 3000 high)	3000 (at 1500 wide)	4.5

## CERTIFICATE No CF811

### Vetrotech Saint-Gobain International AG

**Contraflam Structure 30 Glass (23 mm) in butt jointed timber framed screens for periods of 30 minutes integrity and insulation**

The glass shall be glazed utilising the following basic specification:

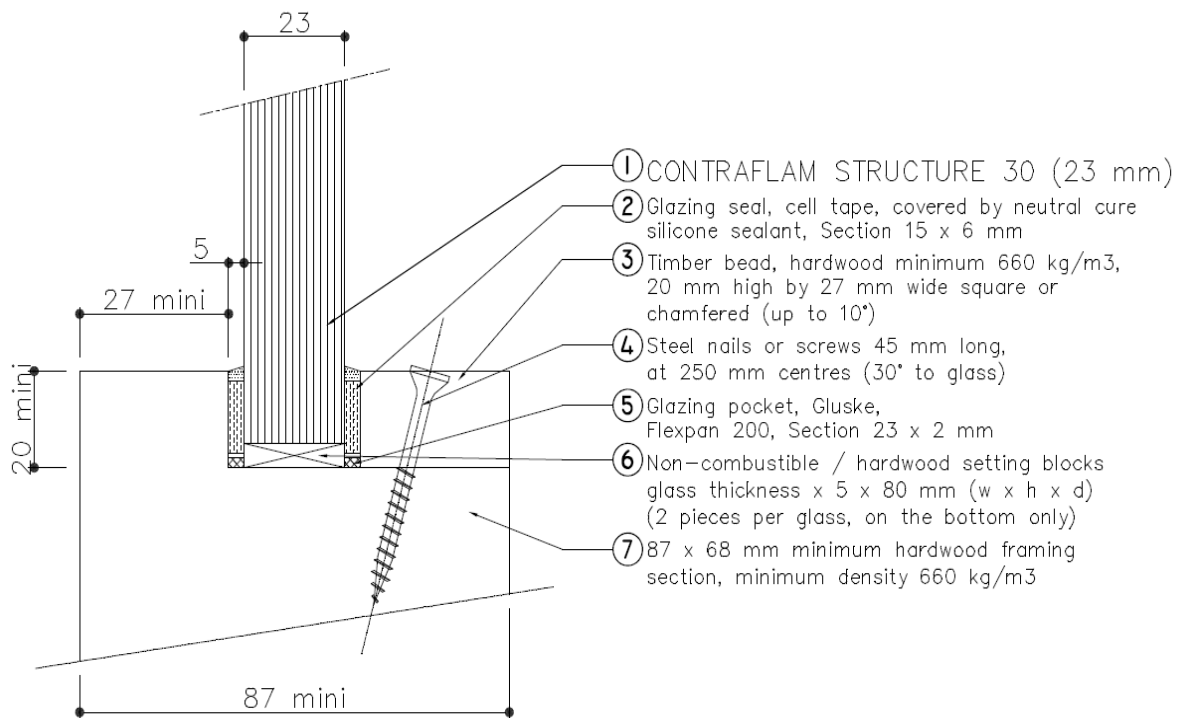

Joints between adjacent panes should be 3 mm wide and sealed with 1 piece of 2 x 13 mm wide 'Palusol T' intumescent strip or 4 mm wide with 2 pieces of 2 x 13mm wide FXL 200 intumescent strips both options top sealed with 'DC895 sealant'.

Max. Width (mm)	Max. Height (mm)	Max. Area (m <sup>2</sup> )
1500 (at 3000 high)	3000 (at 1500 wide)	4.5

## CERTIFICATE No CF811

### Vetrotech Saint-Gobain International AG

#### Contraflam Structure 30 Glass (23 mm) in butt jointed aluminium framed screens for periods of 30 minutes integrity and insulation

The glass shall be installed into the Schueco ADS 80 FR30 system, Aluprof MB-78EI system or Reynaers CS 77-FP system (each of which shall be covered appropriately by test or assessment evidence). The below drawing is an example only.

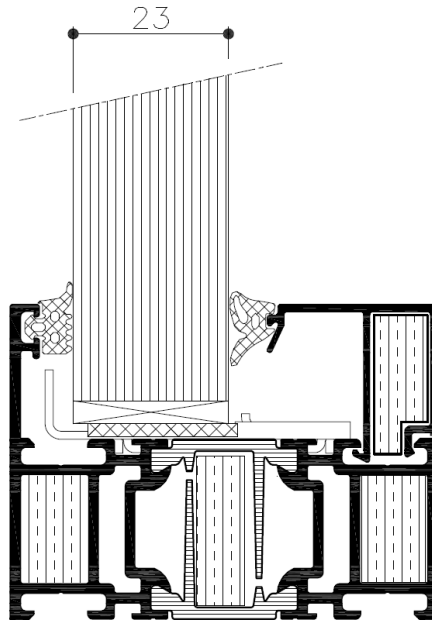

Joints between adjacent panes should be 3 mm wide and sealed with 1 piece of 2 x 13 mm wide 'Palusol T' intumescent strip or 4 mm wide with 2 pieces of 2 x 13mm wide FXL 200 intumescent strips both options top sealed with 'DC895 sealant'.

Table 90 – Maximum Permitted Glass Dimensions		
Max. Width (mm)	Max. Height (mm)	Max. Area (m <sup>2</sup> )
1500 (at 3000 high)	3000 (at 1500 wide)	4.5

## CERTIFICATE No CF811

### Vetrotech Saint-Gobain International AG

#### Contraflam Structure 30 Glass (25 mm) in butt jointed steel framed screens for periods of 60 minutes integrity and 30 minutes insulation

The glass shall be installed into a previously tested or CERTIFIRE approved framing system (which is covered appropriately by test or assessment evidence) using pressure plate glazing, screw-fixed or clip-on retaining beads, see examples below. The glass shall be glazed into the screen as described in the table below and set on non-combustible setting blocks to determine the correct edge cover.

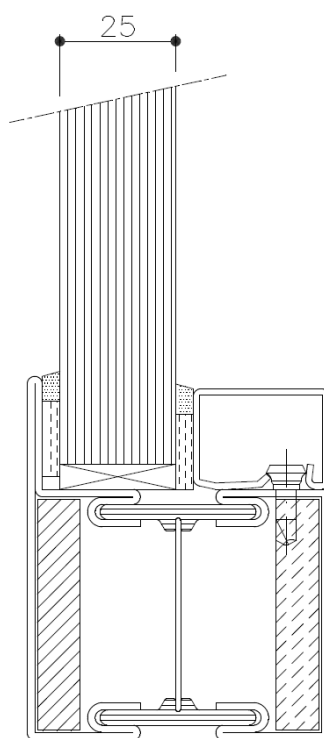

Joints between adjacent panes should be 4 mm wide and sealed with 2 pieces of 2 x 13 mm wide Kerafix FXL 200 intumescent strips and top sealed with Dow Corning 'DC 895' sealant.

Table 91 – Maximum Permitted Glass Dimensions		
Max. Width (mm)	Max. Height (mm)	Max. Area (m <sup>2</sup> )
1033 (at 2362 high)	2362 (at 1033 wide)	2.44

## CERTIFICATE No CF811

### Vetrotech Saint-Gobain International AG

**Contraflam Structure 30 Glass (25 mm) in butt jointed timber framed screens for periods of 60 minutes integrity and 30 minutes insulation**

The glass shall be glazed utilising the following basic specification:

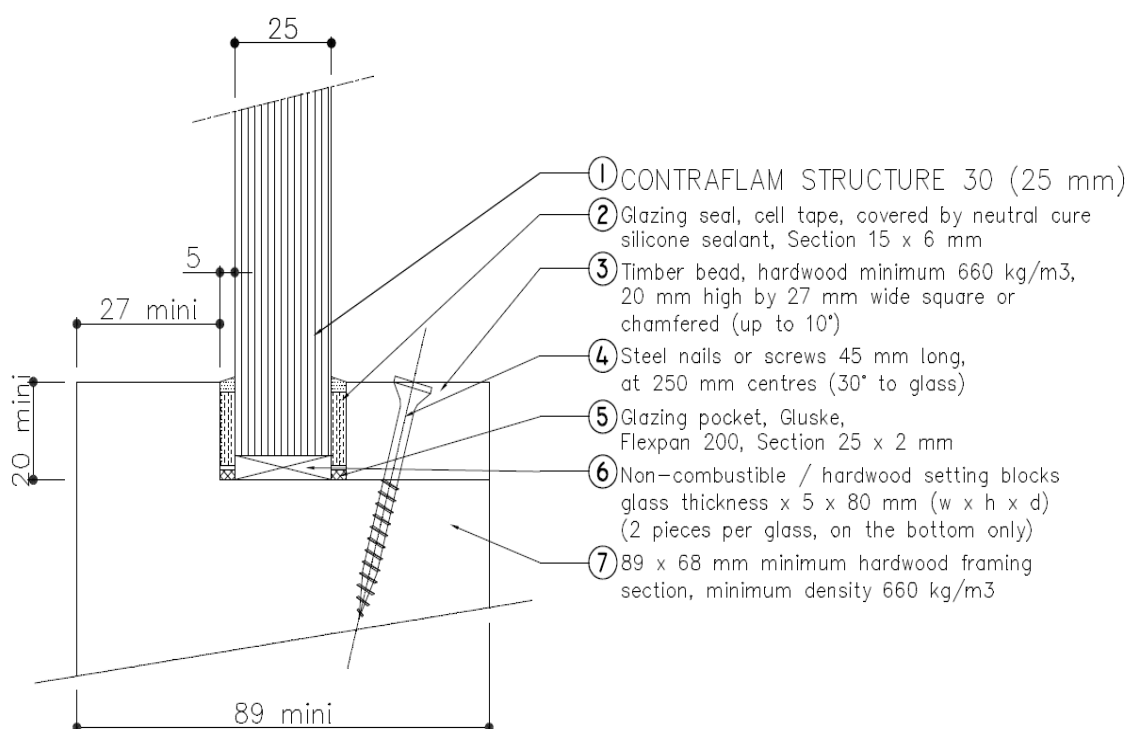

Joints between adjacent panes should be 4 mm wide and sealed with 2 pieces of 2 x 13 mm wide Kerafix FXL 200 intumescent strips and top sealed with Dow Corning 'DC 895' sealant.

Max. Width (mm)	Max. Height (mm)	Max. Area (m <sup>2</sup> )
1033 (at 2362 high)	2362 (at 1033 wide)	2.44

## CERTIFICATE No CF811

### Vetrotech Saint-Gobain International AG

#### Contraflam Structure 30 Glass (28 mm) in butt jointed steel framed screens for periods of 30 minutes integrity and insulation

The glass shall be installed into a previously tested or CERTIFIRE approved framing system (which is covered appropriately by test or assessment evidence) using pressure plate glazing, screw-fixed or clip-on retaining beads, see examples below. The glass shall be glazed into the screen as described in the table below and set on non-combustible setting blocks to determine the correct edge cover.

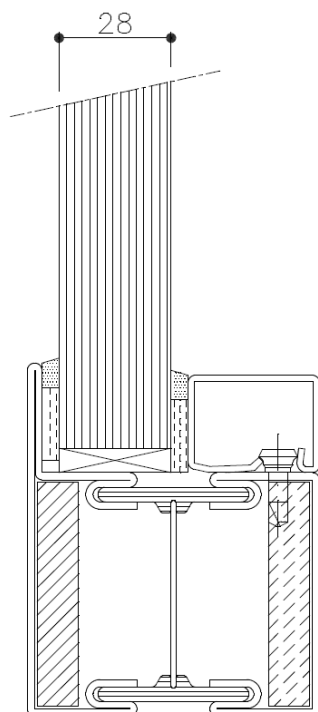

Joints between adjacent panes should be 3 mm wide and sealed with 1 piece of 2 x 18 mm wide 'Palusol T' intumescent strip or 4 mm wide with 2 pieces of 2 x 18mm wide FXL 200 intumescent strips both options top sealed with 'DC895 sealant'.

Table 93 – Maximum Permitted Glass Dimensions		
Max. Width (mm)	Max. Height (mm)	Max. Area (m <sup>2</sup> )
2160 (at 3500 high)	3800 (at 1989 wide)	7.56

## CERTIFICATE No CF811

### Vetrotech Saint-Gobain International AG

**Contraflam Structure 30 Glass (28 mm) in butt jointed timber framed screens for periods of 30 minutes integrity and insulation**

The glass shall be glazed utilising the following basic specification:

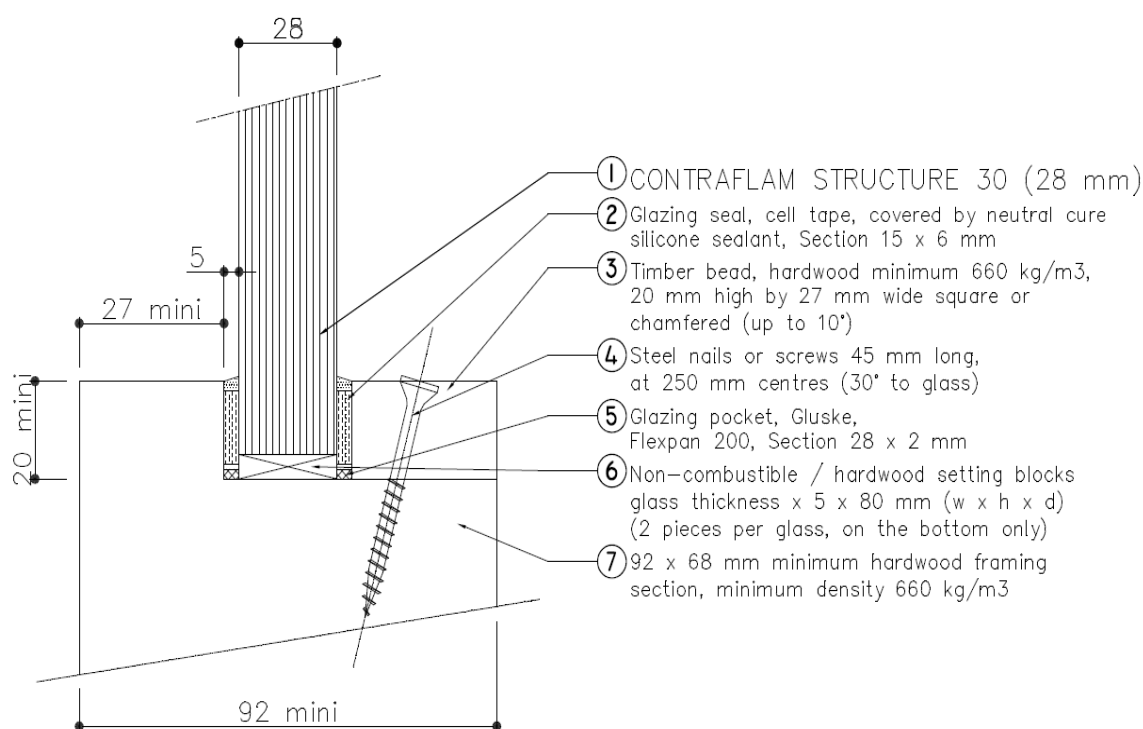

Joints between adjacent panes should be 3 mm wide and sealed with 1 piece of 2 x 18 mm wide 'Palusol T' intumescent strip or 4 mm wide with 2 pieces of 2 x 18mm wide FXL 200 intumescent strips both options top sealed with 'DC895 sealant'.

Max. Width (mm)	Max. Height (mm)	Max. Area (m <sup>2</sup> )
2160 (at 3500 high)	3800 (at 1989 wide)	7.56

## CERTIFICATE No CF811

### Vetrotech Saint-Gobain International AG

#### Contraflam Structure 30 Glass (28 mm) in butt jointed aluminium screens for periods of 30 minutes integrity and insulation

The glass shall be installed into the Schueco ADS 80 FR30 system, Aluprof MB-78EI system or Reynaers CS 77-FP system (each of which shall be covered appropriately by test or assessment evidence). The below drawing is an example only.

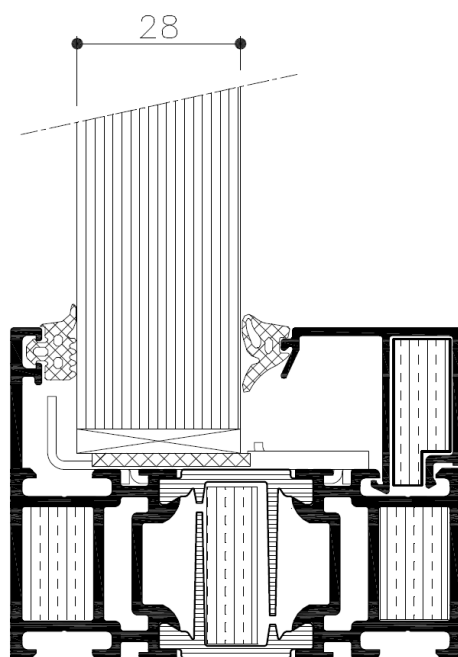

Joints between adjacent panes should be 3 mm wide and sealed with 1 piece of 2 x 18 mm wide 'Palusol T' intumescent strip or 4 mm wide with 2 pieces of 2 x 18 mm wide FXL 200 intumescent strips both options top sealed with 'DC895 sealant'.

Table 95 – Maximum Permitted Glass Dimensions			
System	Max. Width (mm)	Max. Height (mm)	Max. Area (m <sup>2</sup> )
Schueco ADS 80 FR30	1875 (at 3000 high)	3750 (at 1500 wide)	5.625
Aluprof MB-78EI	1800 (at 3000 high)	3600 (at 1500 wide)	5.40
Reynaers CS77-FP	1650 (at 3000 high)	3300 (at 1500 wide)	4.95

## CERTIFICATE No CF811

### Vetrotech Saint-Gobain International AG

#### Contraflam Structure 30 Glass (30 mm) in butt jointed steel framed screens for periods of 30 minutes integrity and insulation

The glass shall be installed into a previously tested or CERTIFIRE approved framing system (which is covered appropriately by test or assessment evidence) using pressure plate glazing, screw-fixed or clip-on retaining beads, see examples below. The glass shall be glazed into the screen as described in the table below and set on non-combustible setting blocks to determine the correct edge cover.

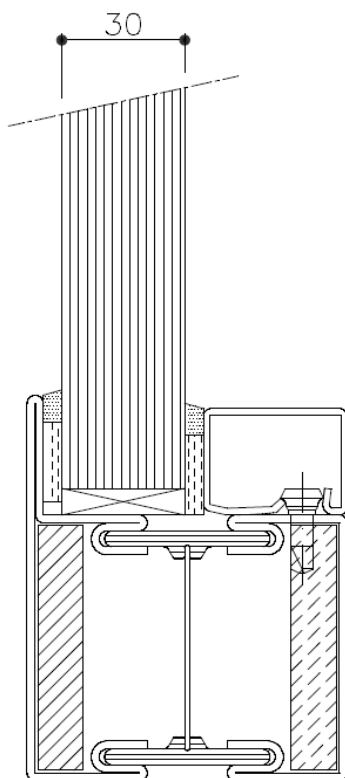

Joints between adjacent panes should be 3 mm wide and sealed with 1 piece of 2 x 20 mm wide 'Palusol T' intumescent strip or 4 mm wide with 2 pieces of 2 x 20 mm wide FXL 200 intumescent strips both options top sealed with 'DC895 sealant'.

Table 96 – Maximum Permitted Glass Dimensions		
Max. Width (mm)	Max. Height (mm)	Max. Area (m <sup>2</sup> )
2160 (at 3500 high)	4200 (at 1800 wide)	7.56

## CERTIFICATE No CF811

### Vetrotech Saint-Gobain International AG

**Contraflam Structure 30 Glass (30 mm) in butt jointed timber framed screens for periods of 30 minutes integrity and insulation**

The glass shall be glazed utilising the following basic specification:

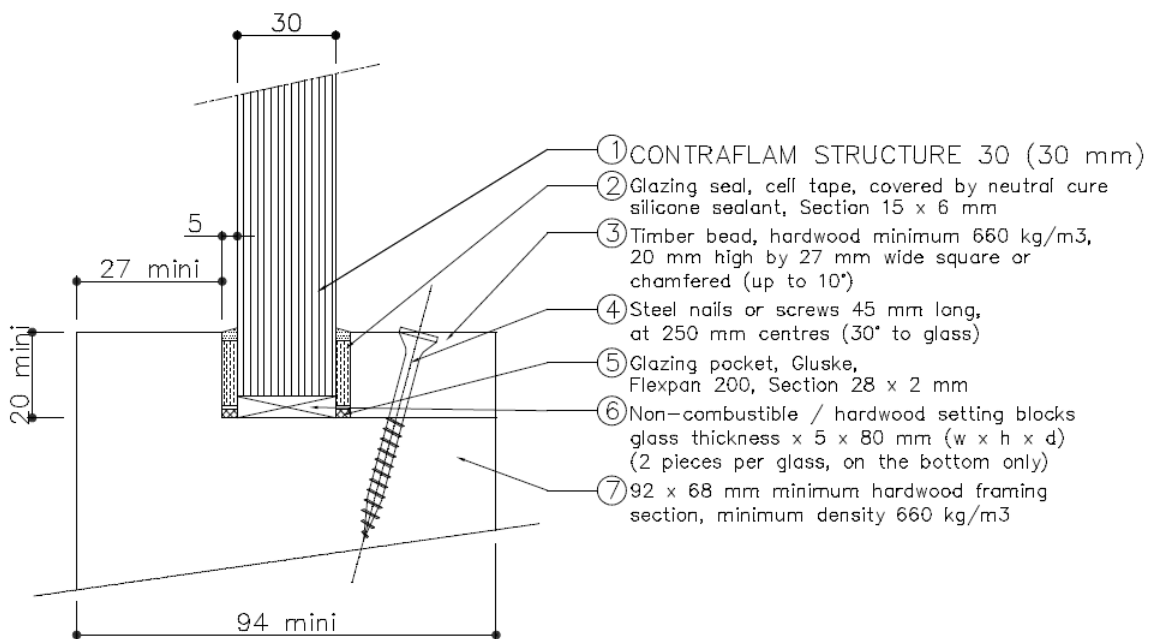

Joints between adjacent panes should be 3 mm wide and sealed with 1 piece of 2 x 20 mm wide 'Palusol T' intumescent strip or 4 mm wide with 2 pieces of 2 x 20 mm wide FXL 200 intumescent strips both options top sealed with 'DC895 sealant'.

Max. Width (mm)	Max. Height (mm)	Max. Area (m <sup>2</sup> )
2160 (at 3500 high)	4200 (at 1800 wide)	7.56

## CERTIFICATE No CF811

### Vetrotech Saint-Gobain International AG

#### Contraflam Structure 30 Glass (30 mm) in butt jointed aluminium screens for periods of 30 minutes integrity and insulation

The glass shall be installed into the Schueco ADS 80 FR30 system, Aluprof MB-78EI system or Reynaers CS 77-FP system (each of which shall be covered appropriately by test or assessment evidence). The below drawing is an example only.

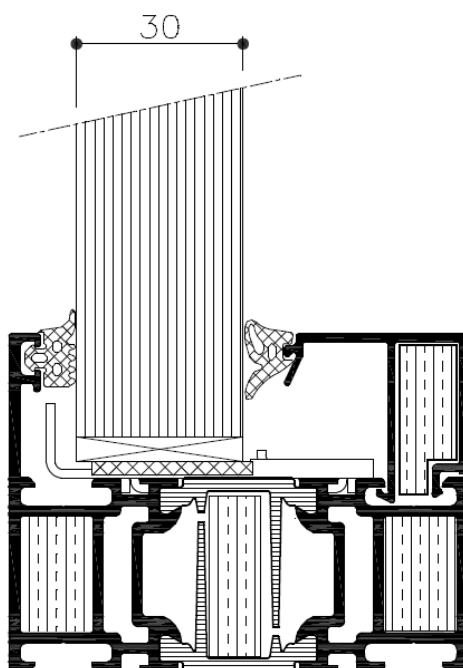

Joints between adjacent panes should be 3 mm wide and sealed with 1 piece of 2 x 20 mm wide 'Palusol T' intumescent strip or 4 mm wide with 2 pieces of 2 x 20 mm wide FXL 200 intumescent strips both options top sealed with 'DC895 sealant'.

System	Max. Width (mm)	Max. Height (mm)	Max. Area (m <sup>2</sup> )
Schueco ADS 80 FR30	1875 (at 3000 high)	3750 (at 1500 wide)	5.625
Aluprof MB-78EI	1800 (at 3000 high)	3600 (at 1500 wide)	5.40
Reynaers CS77-FP	1650 (at 3000 high)	3300 (at 1500 wide)	4.95

## CERTIFICATE No CF811

### Vetrotech Saint-Gobain International AG

#### Contraflam Structure 30 Glass

#### Installation Instruction

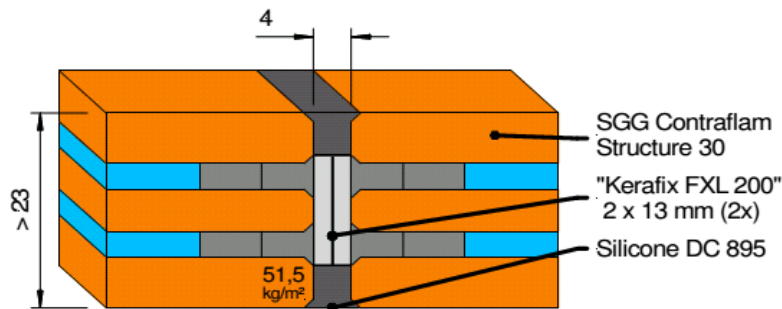

- **Clean the glass edges to be sealed**
  - remove excess polysulphide by razor blade / steel wool "00"
  - clean glass edge with: white spiritus or Dow Corning R41 (do not use other cleaning agents or solvents!)
- **Stick „Kerafix FXL 200“ on vertical glass edges**  
make sure it is centered!
- **Install glass panes and adjust to parallel position**  
glasses can be adjusted to parallel position by some continuous pressure in direction of the glass surfaces
- **Inject silicone "Dow Corning 895" into the joint, remove excessive material and smooth the joint as usual**

## CERTIFICATE No CF811

### Vetrotech Saint-Gobain International AG

#### Contraflam Structure 30 Glass

#### Installation Instruction

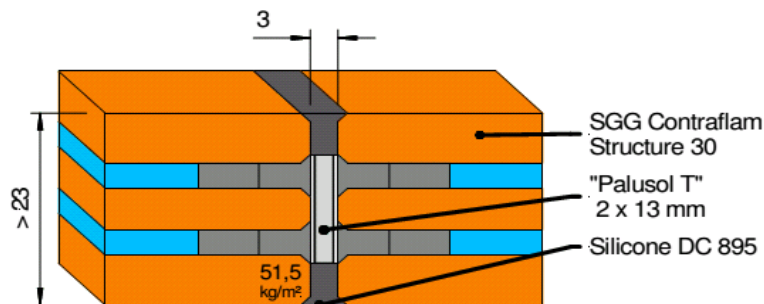

- **Clean the glass edges to be sealed**
  - remove excess polysulphide by razor blade / steel wool "00"
  - clean glass edge with: white spiritus or Dow Corning R41 (do not use other cleaning agents or solvents!)
- **Stick „Palusol T“ on vertical glass edges**  
make sure it is centered!
- **Install glass panes and adjust to parallel position**  
glasses can be adjusted to parallel position by some continuous pressure in direction of the glass surfaces
- **Inject silicone "Dow Corning 895" into the joint, remove excessive material and smooth the joint as usual**

## CERTIFICATE No CF811

### Vetrotech Saint-Gobain International AG

#### Contraflam Structure 30 Corner Glass (23 mm) in butt jointed steel framed screens with 90° corner joints, for periods of 30 minutes integrity and insulation

The glass shall be installed into a previously tested or CERTIFIRE approved framing system (which is covered appropriately by test or assessment evidence) using pressure plate glazing, screw-fixed or clip-on retaining beads, see examples below. The glass shall be glazed into the screen as described in the table below and set on non-combustible setting blocks to determine the correct edge cover.

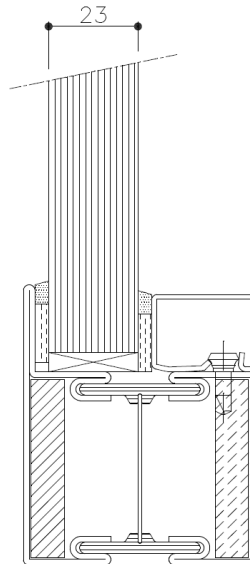

Joints between adjacent panes should be 4 mm wide and sealed with 2 pieces of 2 x 13 mm Kerafix FXL 200 intumescent strips or 3 mm wide with 1 piece of 2 x 13 mm Palusol T both top sealed with Dow Corning 'DC 895' sealant. Adjacent panes for 90° joints should be 3 mm wide and sealed with 1 piece of 2 x 23 mm Palusol T intumescent strip or 4 mm wide with 2 pieces of 2 x 23mm wide FXL 200 intumescent strips both options top sealed with 'DC895 sealant'.

Table 99 – Maximum Permitted Glass Dimensions		
Max. Width (mm)	Max. Height (mm)	Max. Area (m <sup>2</sup> )
1200 (at 3000 high)	3000 (at 1200 wide)	3.6

## CERTIFICATE No CF811

### Vetrotech Saint-Gobain International AG

**Contraflam Structure 30 Corner Glass (23 mm) in butt jointed timber framed screens with 90° corner joints, for periods of 30 minutes integrity and insulation**

The glass shall be glazed utilising the following basic specification:

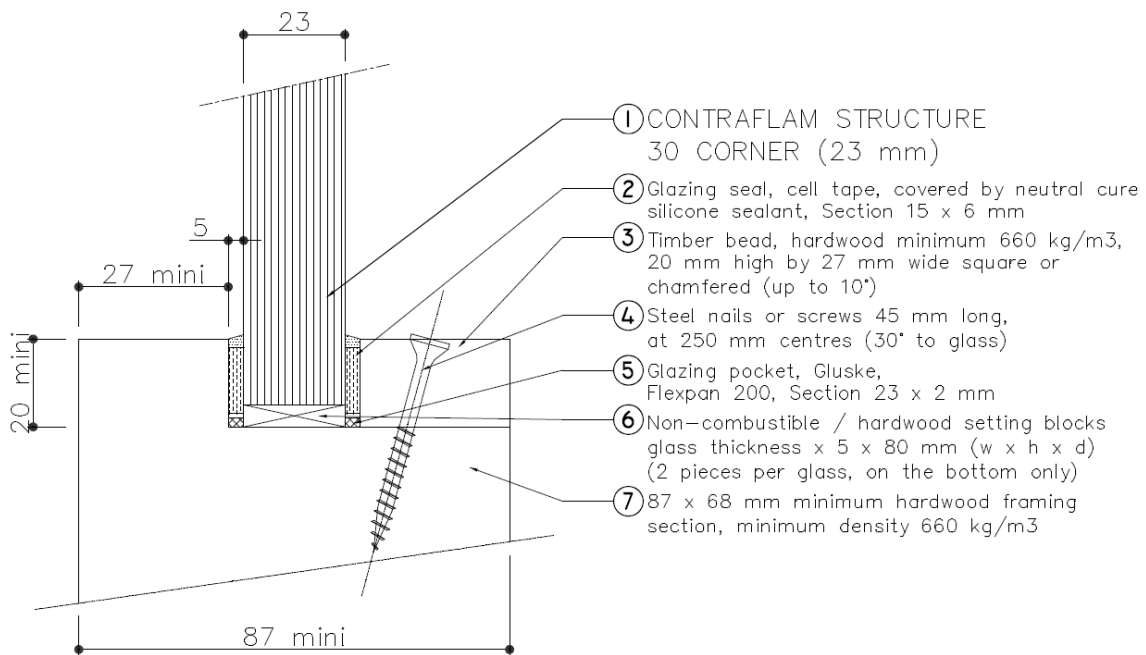

Joints between adjacent panes should be 4 mm wide and sealed with 2 pieces of 2 x 13 mm Kerafix FXL 200 intumescent strips or 3 mm wide with 1 piece of 2 x 13 mm Palusol T both top sealed with Dow Corning 'DC 895' sealant. Adjacent panes for 90° joints should be 3 mm wide and sealed with 1 piece of 2 x 23 mm Palusol T intumescent strip or 4 mm wide with 2 pieces of 2 x 23 mm wide FXL 200 intumescent strips both options top sealed with 'DC895 sealant'.

**Table 100 – Maximum Permitted Glass Dimensions**

Max. Width (mm)	Max. Height (mm)	Max. Area (m <sup>2</sup> )
1200 (at 3000 high)	3000 (at 1200 wide)	3.6

## CERTIFICATE No CF811

### Vetrotech Saint-Gobain International AG

**Contraflam Structure 30 Corner Glass (23 mm) in butt jointed Schueco ADS 80 FR30 aluminium screens with 90° corner joints, for periods of 30 minutes integrity and insulation**

The glass shall be installed into the Schueco ADS 80 FR30 system (which shall be covered appropriately by test or assessment evidence).

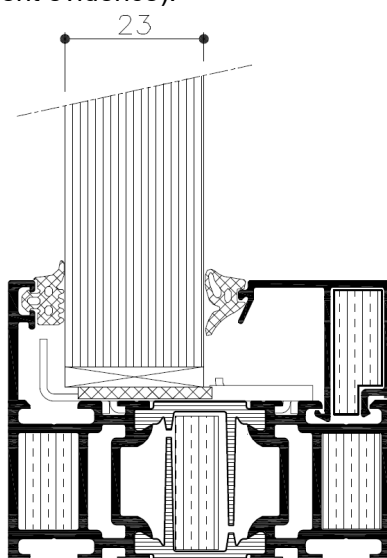

Joints between adjacent panes should be 4 mm wide and sealed with 2 pieces of 2 x 13 mm Kerafix FXL 200 intumescent strips or 3 mm wide with 1 piece of 2 x 13 mm Palusol T both top sealed with Dow Corning 'DC 895' sealant. Adjacent panes for 90° joints should be 3 mm wide and sealed with 1 piece of 2 x 23 mm Palusol T intumescent strip or 4 mm wide with 2 pieces of 2 x 23mm wide FXL 200 intumescent strips both options top sealed with 'DC895 sealant'.

**Table 101 – Maximum Permitted Glass Dimensions**

Max. Width (mm)	Max. Height (mm)	Max. Area (m <sup>2</sup> )
1200 (at 3000 high)	3000 (at 1200 wide)	3.6

## CERTIFICATE No CF811

### Vetrotech Saint-Gobain International AG

#### Contraflam Structure 30 Corner Glass (28 mm) in butt jointed steel framed screens with 90° corner joints, for periods of 30 minutes integrity and insulation

The glass shall be installed into a previously tested or CERTIFIRE approved framing system (which is covered appropriately by test or assessment evidence) using pressure plate glazing, screw-fixed or clip-on retaining beads, see examples below. The glass shall be glazed into the screen as described in the table below and set on non-combustible setting blocks to determine the correct edge cover.

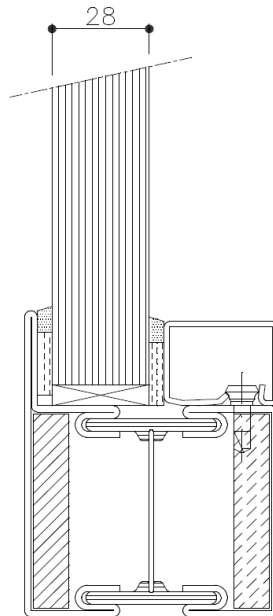

Joints between adjacent panes should be 4 mm wide and sealed with 2 pieces of 2 x 18 mm Kerafix FXL 200 intumescent strips or 3 mm wide with 1 piece of 2 x 18 mm Palusol T both top sealed with Dow Corning 'DC 895' sealant. Adjacent panes for 90° joints should be 3 mm wide and sealed with 1 piece of 2 x 28 mm Palusol T intumescent strip or 4 mm wide with 2 x 28mm wide FXL 200 intumescent strips both options top sealed with 'DC895 sealant'.

Table 102 – Maximum Permitted Glass Dimensions		
Max. Width (mm)	Max. Height (mm)	Max. Area (m <sup>2</sup> )
1320 (at 3000 high)	3300 (at 1237 wide)	3.98

## CERTIFICATE No CF811

### Vetrotech Saint-Gobain International AG

**Contraflam Structure 30 Corner Glass (28 mm) in butt jointed timber framed screens with 90° corner joints, for periods of 30 minutes integrity and insulation**

The glass shall be glazed utilising the following basic specification:

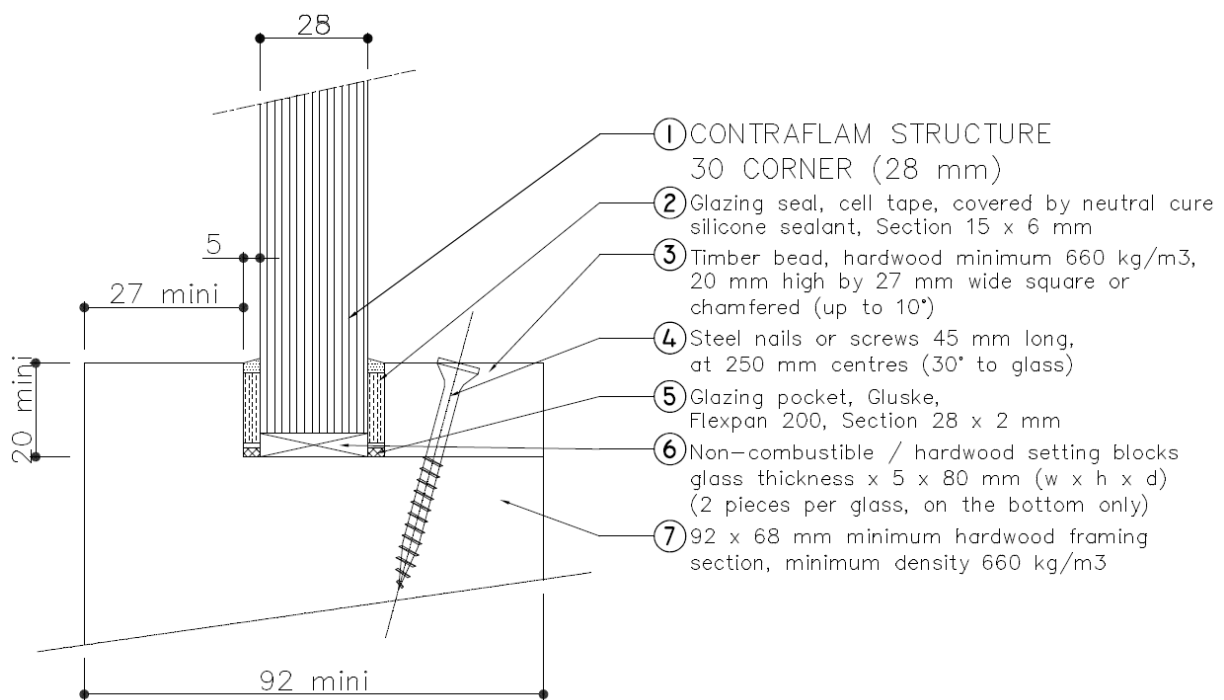

Joints between adjacent panes should be 4 mm wide and sealed with 2 pieces of 2 x 18 mm Kerafix FXL 200 intumescent strips or 3 mm wide with 1 piece of 2 x 18 mm Palusol T both top sealed with Dow Corning 'DC 895' sealant. Adjacent panes for 90° joints should be 3 mm wide and sealed with 1 piece of 2 x 28 mm Palusol T intumescent strip or 4 mm wide with 2 pieces of 2 x 28 mm wide FXL 200 intumescent strips both options top sealed with 'DC895 sealant'.

**Table 103 – Maximum Permitted Glass Dimensions**

Max. Width (mm)	Max. Height (mm)	Max. Area (m <sup>2</sup> )
1320 (at 3000 high)	3300 (at 1237 wide)	3.98

## CERTIFICATE No CF811

### Vetrotech Saint-Gobain International AG

**Contraflam Structure 30 Corner Glass (28 mm) in butt jointed Schueco ADS 80 FR30 aluminium screens with 90° corner joints, for periods of 30 minutes integrity and insulation**

The glass shall be installed into the Schueco ADS 80 FR30 system (which shall be covered appropriately by test or assessment evidence).

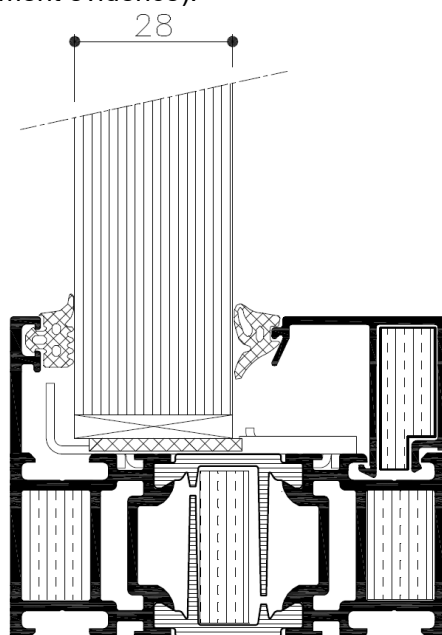

Joints between adjacent panes should be 4 mm wide and sealed with 2 pieces of 2 x 18 mm Kerafix FXL 200 intumescent strips or 3 mm wide with 1 piece of 2 x 18 mm Palusol T both top sealed with Dow Corning 'DC 895' sealant. Adjacent panes for 90° joints should be 3 mm wide and sealed with 1 piece of 2 x 28 mm Palusol T intumescent strip or 4 mm wide with 2 pieces of 2 x 28mm wide FXL 200 intumescent strips both options top sealed with 'DC895 sealant'.

Table 104 – Maximum Permitted Glass Dimensions		
Max. Width (mm)	Max. Height (mm)	Max. Area (m <sup>2</sup> )
1320 (at 3000 high)	3300 (at 1237 wide)	3.98

## CERTIFICATE No CF811 Vetrotech Saint-Gobain International AG

### Contraflam Structure 30 Corner Glass

#### Installation Instruction

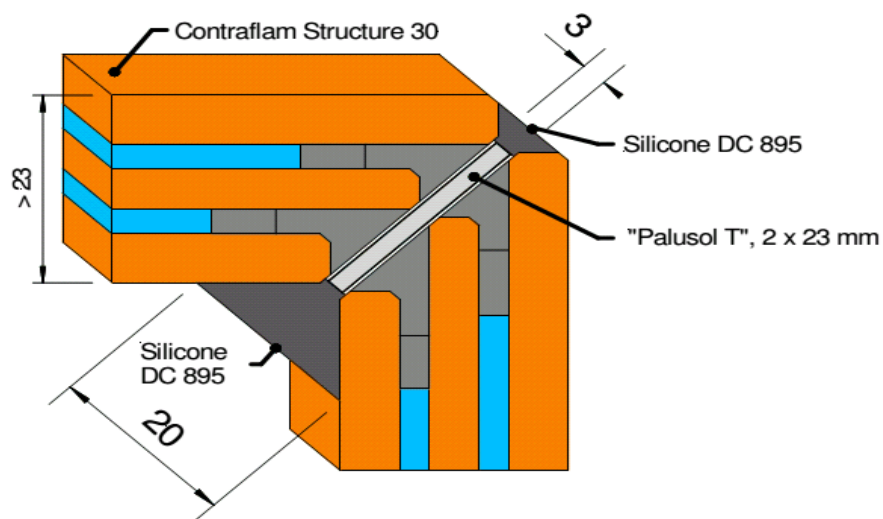

- **Clean the glass edges to be sealed**
  - remove excess polysulphide by razor blade / steel wool "00"
  - clean glass edge with: white spiritus or Dow Corning R41 (do not use other cleaning agents or solvents!)
- **Stick „Palusol T“ on vertical glass edges**  
make sure it is centered!
- **Install glass panes and adjust to correct position**  
glasses can be adjusted to correct position by some continuous pressure in direction of the glass surfaces
- **Inject silicone "Dow Corning 895" into the joint, remove excessive material and smooth the joint as usual**

## CERTIFICATE No CF811 Vetrotech Saint-Gobain International AG

### Contraflam Structure 30 Corner Glass

#### Installation Instruction

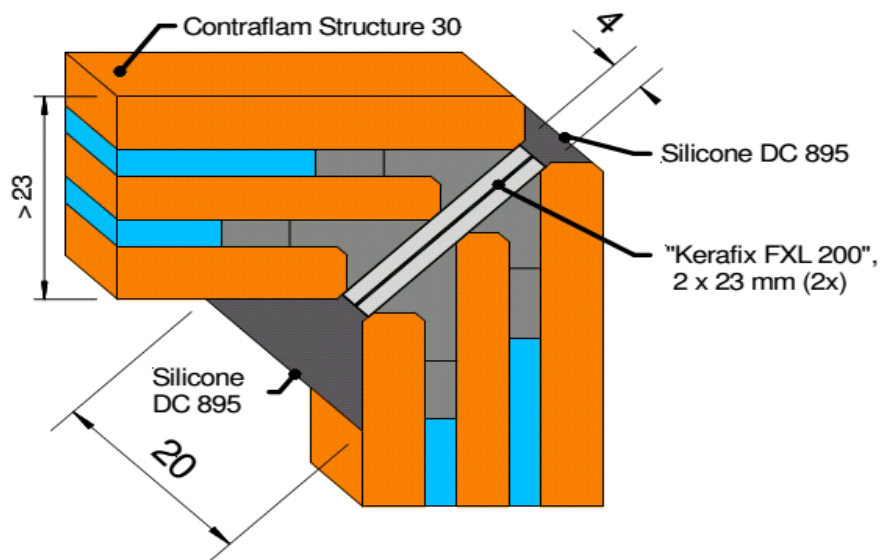

- **Clean the glass edges to be sealed**
  - remove excess polysulphide by razor blade / steel wool "00"
  - clean glass edge with: white spiritus or Dow Corning R41 (do not use other cleaning agents or solvents!)
- **Stick „Kerafix FXL 200“ on vertical glass edges**  
make sure it is centered!
- **Install glass panes and adjust to correct position**  
glasses can be adjusted to correct position by some continuous pressure in direction of the glass surfaces
- **Inject silicone "Dow Corning 895" into the joint, remove excessive material and smooth the joint as usual**

## CERTIFICATE No CF811

### Vetrotech Saint-Gobain International AG

#### Contraflam Structure 30 IGU Glass in butt jointed steel framed screens for periods of 30 minutes integrity and insulation

The glass shall be installed into a previously tested or CERTIFIRE approved framing system (which is covered appropriately by test or assessment evidence) using pressure plate glazing, screw-fixed or clip-on retaining beads, see examples below. The glass shall be glazed into the screen as described in the table below and set on non-combustible setting blocks to determine the correct edge cover.

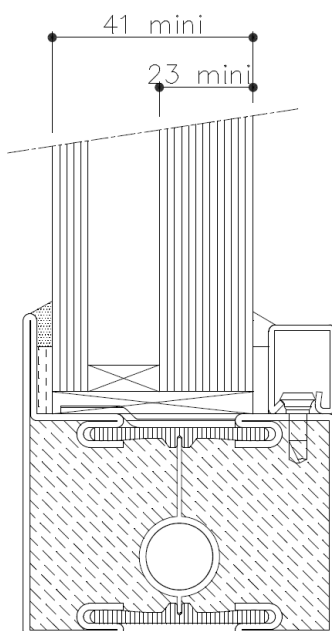

Joints between adjacent panes for internal application should be 4 mm wide and sealed with 2 pieces of 2 x (xx\*) mm wide Kerafix FXL 200 intumescent strips or for external application Flextrem 100 with 2 pieces of 2 x (xx\*) mm and top sealed with Dow Corning 'DC 895' sealant.

xx\* = Overall glass thickness – 10 mm

Table 105 – Maximum Permitted Glass Dimensions		
Max. Width (mm)	Max. Height (mm)	Max. Area (m <sup>2</sup> )
1800 (at 3027 high)	3500 (at 1557 wide)	5.45

## CERTIFICATE No CF811

### Vetrotech Saint-Gobain International AG

#### Contraflam Structure 30 IGU Glass in butt jointed timber framed screens for periods of 30 minutes integrity and insulation

The glass shall be glazed utilising the following basic specification:

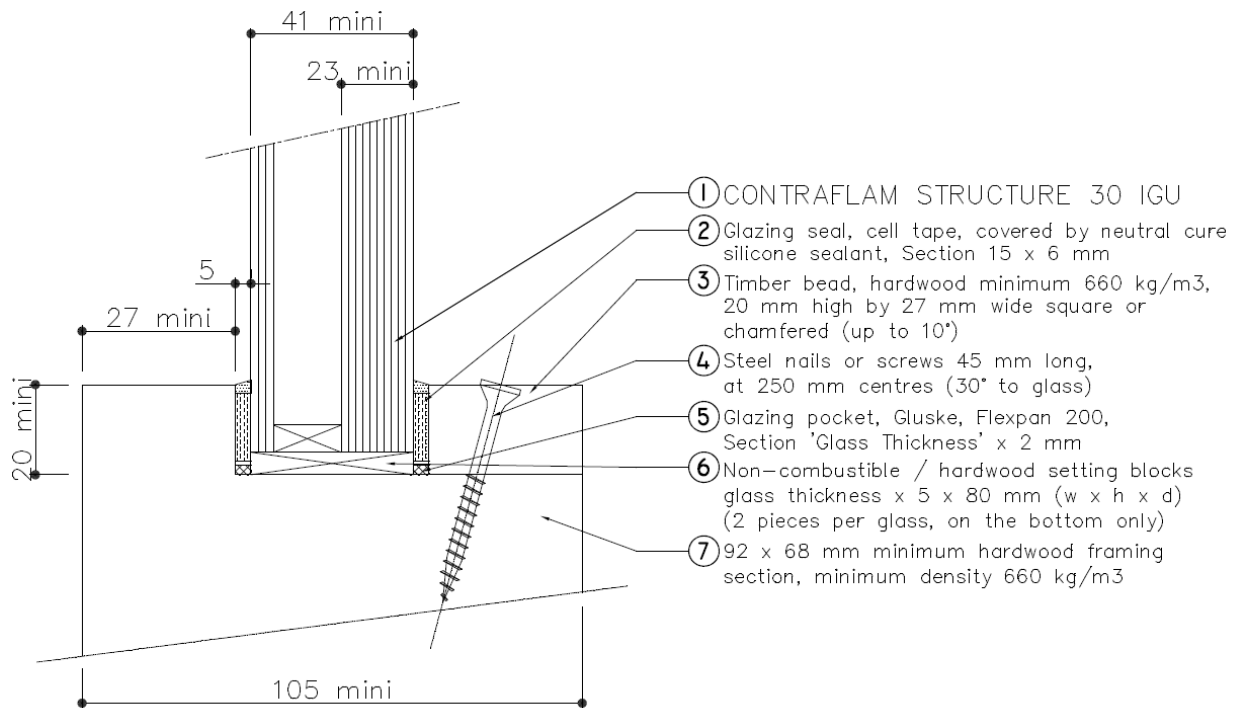

Joints between adjacent panes for internal application should be 4 mm wide and sealed with 2 pieces of 2 x (xx\*) mm wide Kerafix FXL 200 intumescent strips or for external application Flextrem 100 with 2 pieces of 2 x (xx\*) mm and top sealed with Dow Corning 'DC 895' sealant.

xx\* = Overall glass thickness – 10 mm

Table 106 – Maximum Permitted Glass Dimensions		
Max. Width (mm)	Max. Height (mm)	Max. Area (m <sup>2</sup> )
1800 (at 3027 high)	3500 (at 1557 wide)	5.45

## CERTIFICATE No CF811

### Vetrotech Saint-Gobain International AG

**Contraflam Structure 30 IGU Glass in butt jointed Schueco ADS 80 FR30 aluminium framed screens for periods of 30 minutes integrity and insulation**

The glass shall be installed into the Schueco ADS 80 FR30 system (which shall be covered appropriately by test or assessment evidence).

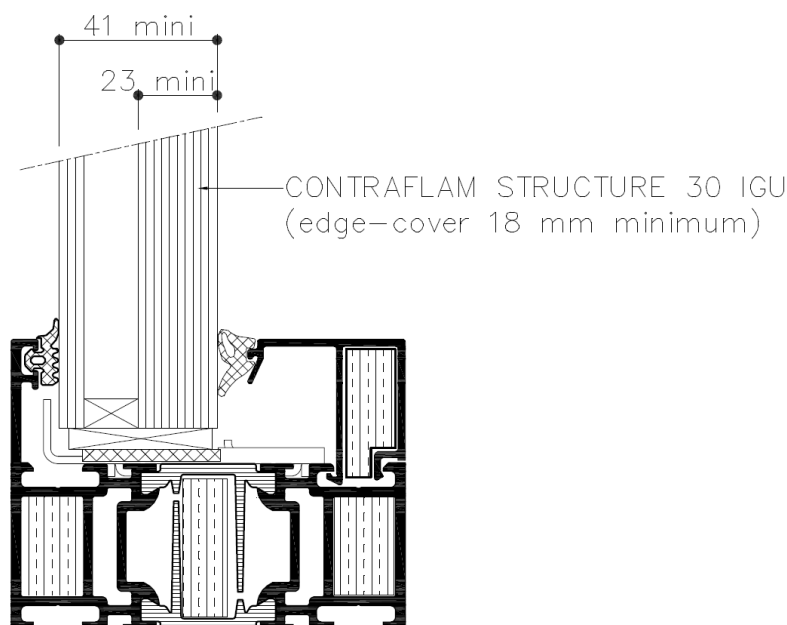

Joints between adjacent panes for internal application should be 4 mm wide and sealed with 2 pieces of 2 x (xx\*) mm wide Kerafix FXL 200 intumescent strips or for external application Flexirem 100 with 2 pieces of 2 x (xx\*) mm and top sealed with Dow Corning 'DC 895' sealant.

xx\* = Overall glass thickness – 10 mm

Table 107 – Maximum Permitted Glass Dimensions		
Max. Width (mm)	Max. Height (mm)	Max. Area (m <sup>2</sup> )
1500 (at 3000 high)	3500 (at 1285 wide)	4.50

## CERTIFICATE No CF811 Vetrotech Saint-Gobain International AG

### Contraflam Structure 30 IGU Glass

#### CONTRAFLAM STRUCTURE 30 IGU

#### Installation Instruction

#### For interior use only!

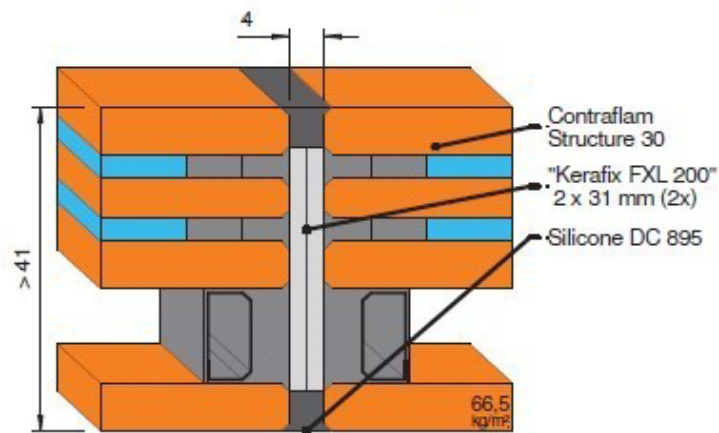

- **Clean the glass edges to be sealed**
  - remove excess polysulphide by razor blade / steel wool "00"
  - clean glass edge with: white spiritus or Dow Corning R41 (do not use other cleaning agents or solvents!)
- **Stick „Kerafix FXL 200“ on vertical glass edges**  
make sure it is centered!
- **Install glass panes and adjust to parallel position**  
glasses can be adjusted to parallel position by some continuous pressure in direction of the glass surfaces
- **Inject silicone "Dow Corning 895" into the joint, remove excessive material and smooth the joint as usual**

## CERTIFICATE No CF811

### Vetrotech Saint-Gobain International AG

#### Contraflam Structure 30 IGU Glass

#### CONTRAFLAM STRUCTURE 30 IGU

#### Installation Instruction

#### For interior and exterior use

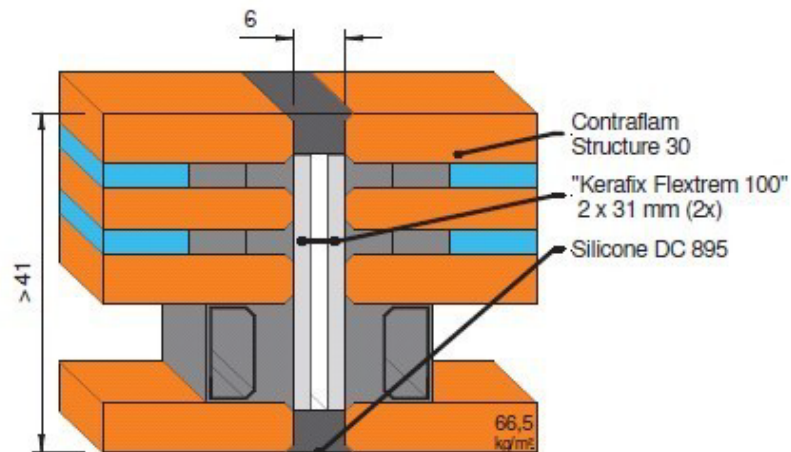

- **Clean the glass edges to be sealed**
  - remove excess polysulphide by razor blade / steel wool "00"
  - clean glass edge with: white spiritus or Dow Corning R41 (do not use other cleaning agents or solvents!)
- **Stick „Kerafix Flextrem 100“ on vertical glass edges**  
make sure it is centered!
- **Install glass panes and adjust to parallel position**  
glasses can be adjusted to parallel position by some continuous pressure in direction of the glass surfaces
- **Inject silicone "Dow Corning 895" into the joint, remove excessive material and smooth the joint as usual**

## CERTIFICATE No CF811

### Vetrotech Saint-Gobain International AG

#### Contraflam Structure 30 Corner IGU in steel framed screen with 90° to 180° corner joints for 30 minutes integrity and insulation

The glass shall be installed into a previously tested or CERTIFIRE approved framing system (which is covered appropriately by test or assessment evidence) using pressure plate glazing, screw-fixed or clip-on retaining beads, see examples below. The glass shall be glazed into the screen as described in the table below and set on non-combustible setting blocks to determine the correct edge cover.

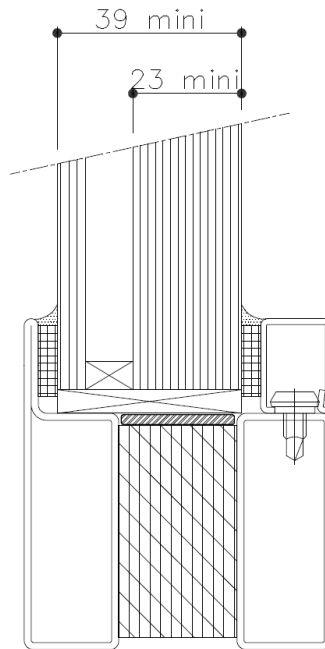

Joints between adjacent panes for external and internal applications should be 6 mm wide and sealed with 2 pieces of 2x25 mm wide 'Flexilodice SA' intumescent strips and top sealed with Dow Corning 'DC 895' sealant. Adjacent panes for 90°-180° joints should be 6 mm wide and sealed with 2 pieces of 2 x (xx\*) mm wide 'Flexilodice SA' intumescent strips and top sealed with Dow Corning 'DC 895' sealant.

$$*xx = (\text{glass thickness (mm)} \times \sqrt{2}) - 8 \text{ mm}$$

Table 108 – Maximum Permitted Glass Dimensions		
Max. Width (mm)	Max. Height (mm)	Max. Area (m <sup>2</sup> )
1650 (at 3000 high)	3300 (at 1500 wide)	4.95

## CERTIFICATE No CF811

### Vetrotech Saint-Gobain International AG

#### Contraflam Structure 30 Corner IGU

##### Installation Instruction

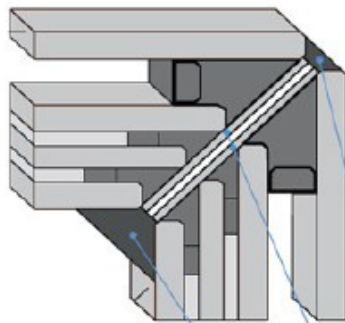

Silicone:  
"Dow Corning DC 895"

Doubled-up (2) "Flexilodice SA" expanding  
intumescent seals. Width (W) of the seal  
is dependent on the thickness of the glass.

Silicone:  
"Dow Corning DC 895"

- **Clean the glass edges to be sealed**
  - remove excess polysulphide by razor blade / steel wool "00"
  - clean glass edge with: white spiritus or Dow Corning R41  
(do not use other cleaning agents or solvents!)
- **Stick "Flexilodice SA" on vertical glass edges**
  - make sure it is centred!
- **Install glass panes and adjust to parallel position**
  - Glasses can be adjusted to parallel position by some continuous pressure in direction of the glass surfaces
- **Inject silicone "Dow Corning 895" into the joint, remove excessive material and smooth the joint as usual.**

Page 129 of 194 Signed  
E014243-3, E014243-4

Issued: 2<sup>nd</sup> July 2025  
Valid to: 1<sup>st</sup> July 2030

EWC-QU-FT-733 (Issue 2)

## CERTIFICATE No CF811

### Vetrotech Saint-Gobain International AG

**Contraflam Structure 30 Point Glass (23 mm) in 'Point-Wise' mounting for periods of 60 minutes integrity and 30 minutes insulation**

Glazed wall constructions with silicone glass joints and point-wise mounting of Contraflam Structure 30 Point glass as follows:

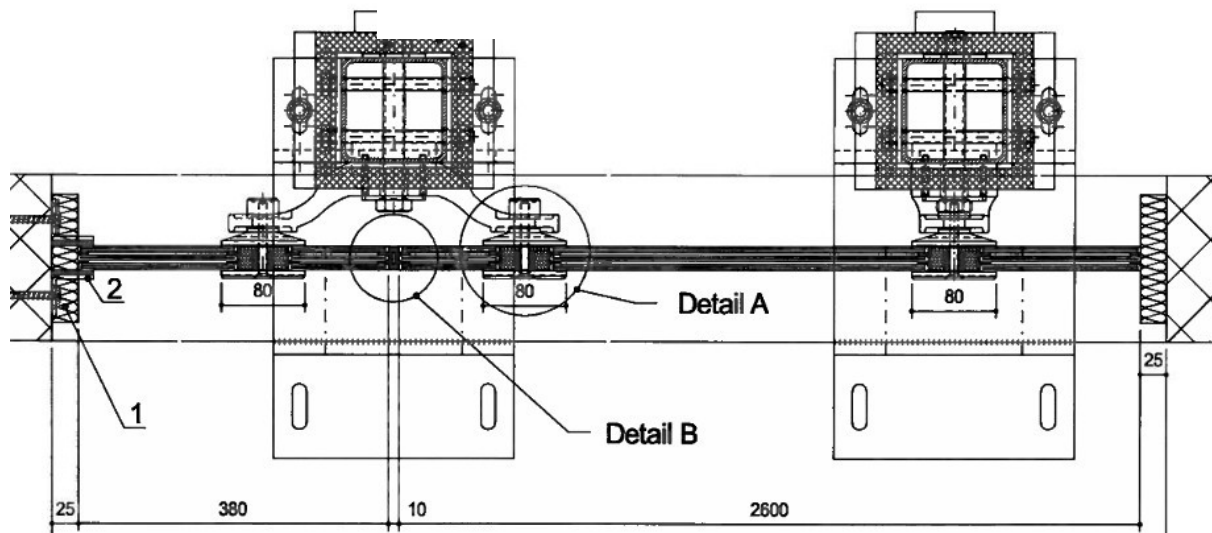

Joints between panes should be 10 mm wide (+/- 2 mm) and sealed with 2 pieces of 14 x 4 mm (8 mm total thickness) Tenmat Firefly 107 self-adhesive intumescent strips and top sealed with Dow Corning 'DC 895' sealant.

Table 109 – Maximum Permitted Glass Dimensions		
Max. Width (mm)	Max. Height (mm)	Max. Area (m <sup>2</sup> )
2600 (at 1325 high)	1325 (at 2600 wide)	3.45

The screens shall be no greater than 4000 mm high unless suitable tie backs and/or fire protected structural supports are provided.

## CERTIFICATE No CF811

### Vetrotech Saint-Gobain International AG

**Contraflam Structure 30 Point Glass (23 mm) in 'Point-Wise' mounting for periods of 60 minutes integrity and 30 minutes insulation**

#### Point fixing requirements

- The glass shall be installed into a previously tested 'Spider-arm' framing system (which is covered appropriately by test or assessment evidence) using pressure plate glazing to the required performance.
- Elongated holes 9 x 20 mm (allowing expansion) serve as point support on the bottom edge of the glass and 20 mm dia. drilled holes as point-support in the upper edge of the glass (minimum 4 fixings per pane (see below)).
- Maximum location from the glass edge will be 120 mm, and maximum distance between fixing points will be 2360 mm.
- Where the pane  $\leq 380$  mm wide only one fixing top and bottom is required
- Where 'spider joint' is fixed through the glass pane, the installation specification will be as Detail A below.
- Joints between panes will be as Detail B below.

Detail A

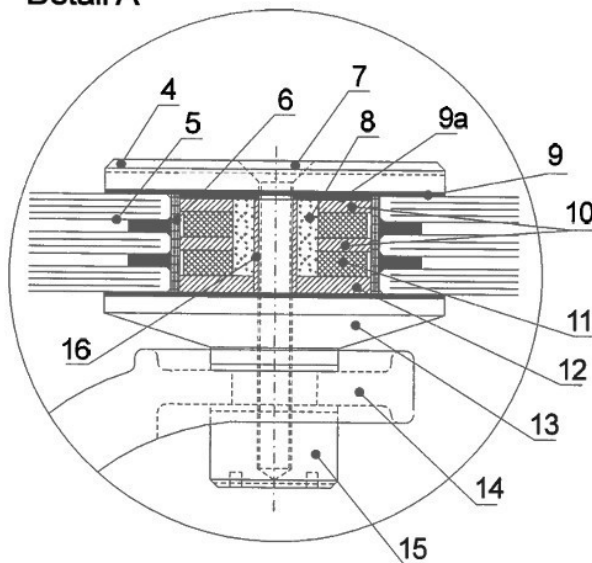

Detail B

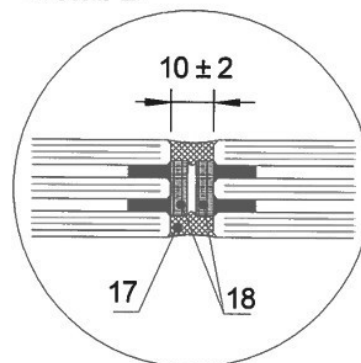

## CERTIFICATE No CF811

### Vetrotech Saint-Gobain International AG

Contraflam Structure 30 Point Glass (23 mm) in 'Point-Wise' mounting for periods of 60 minutes integrity and 30 minutes insulation

- 1) Mineral wool
- 2) Steel angle 40 x 40 x 5 mm, 30 mm long
- 3) Steel beam, 1000 x 1000 x 4 x 3940 mm
- 4) Stainless steel plate, Ø 80 mm, 7 mm thick
- 5) "Contraflam Structure 30", 23 mm thick
  - Tempered glass 6 mm
  - Interlayer 3 mm
  - Tempered glass 5 mm
  - Interlayer 3 mm
  - Tempered glass 6 mm
- 6) Non-compressible gasket, 22 x 2, 147 mm long
- 7) Machine screw, stainless, M8 x 75 mm
- 8) Hilti Hit-HY 150 Max 330/2
- 9) Non-compressible gasket, Ø 80 mm, 1 mm thick
- 9a) Tolerance gasket, non-compressible, Ø 45 mm, 1 mm thick,
- 10) Washer, stainless, Ø 45 x 3 mm, inner Ø 20 mm
- 11) Washer, Promatect H, Ø 43 x 6 mm, inner Ø 20 mm
- 12) Washer, stainless, Ø 45 x 4 mm, inner Ø 10 mm
- 13) Stainless steel plate, Ø 80 mm, 4-12 mm thick
- 14) Spider, cast steel
- 15) Nut, stainless, M8, outer Ø 30 mm
- 16) Tube, stainless, Ø 10 mm, inner Ø 8 mm, 22 mm long
- 17) Silicone, Dow Corning DC 895
- 18) Tenmat, Firefly 107 self adhesive, 14 x 4 mm
- 19) Boards, Rigips, Glasroc F, 20 mm
- 20) Cramp, 63 mm
- 21) Machine screw, steel, M20 x 160 mm

## CERTIFICATE No CF811

### Vetrotech Saint-Gobain International AG

#### Contraflam Structure 60 Glass (31 mm) in butt jointed steel framed screens for periods of 60 minutes integrity and insulation

The glass shall be installed into a previously tested or CERTIFIRE approved framing system (which is covered appropriately by test or assessment evidence) using pressure plate glazing, screw-fixed or clip-on retaining beads, see examples below. The glass shall be glazed into the screen as described in the table below and set on non-combustible setting blocks to determine the correct edge cover.

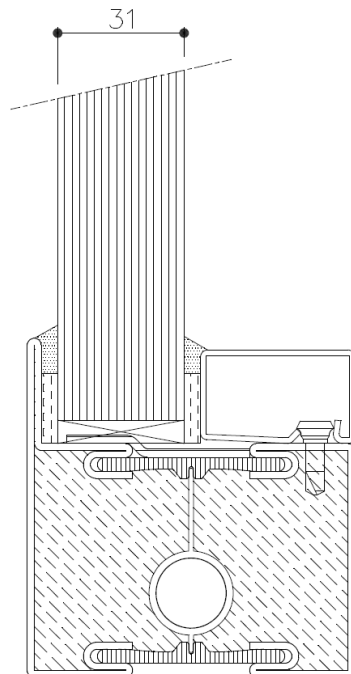

Joints between adjacent panes should be 4 mm wide and sealed with 2 pieces of 2 x 21 mm wide Kerafix FXL 200 intumescent strips and top sealed with Dow Corning 'DC 895' sealant.

Table 110 – Maximum Permitted Glass Dimensions		
Max. Width (mm)	Max. Height (mm)	Max. Area (m <sup>2</sup> )
1500 (at 3000 high)	3000 (at 1500 wide)	4.5

## CERTIFICATE No CF811

### Vetrotech Saint-Gobain International AG

**Contraflam Structure 60 Glass (31 mm) in butt jointed timber framed screens for periods of 60 minutes integrity and insulation**

The glass shall be glazed utilising the following basic specification:

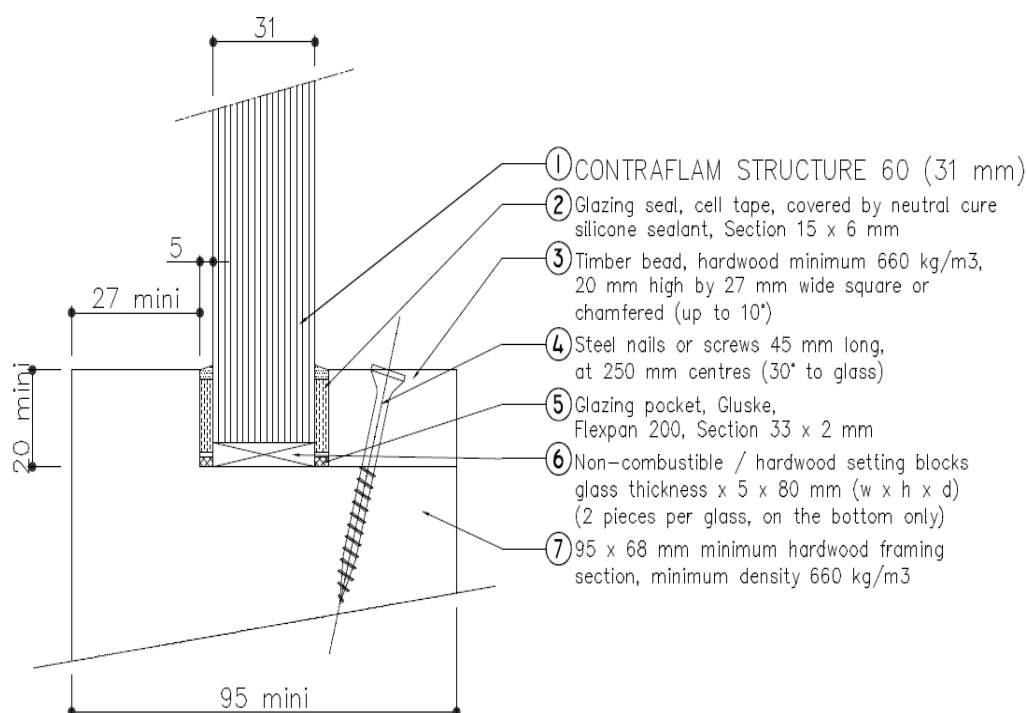

Joints between adjacent panes should be 4 mm wide and sealed with 2 pieces of 2 x 21 mm wide Kerafix FXL 200 intumescent strips and top sealed with Dow Corning 'DC 895' sealant.

**Table 111 – Maximum Permitted Glass Dimensions**

Max. Width (mm)	Max. Height (mm)	Max. Area (m <sup>2</sup> )
1500 (at 3000 high)	3000 (at 1500 wide)	4.5

## CERTIFICATE No CF811

### Vetrotech Saint-Gobain International AG

**Contraflam Structure 60 Glass (31 mm) in butt jointed Schueco ADS 80 FR60 system or Aluprof MB-78EI aluminium framed screens for periods of 60 minutes integrity and insulation**

The glass shall be installed into the Schueco ADS 80 FR60 system or the Aluprof MB-78EI system (each of which shall be covered appropriately by test or assessment evidence). The below drawing is an example only.

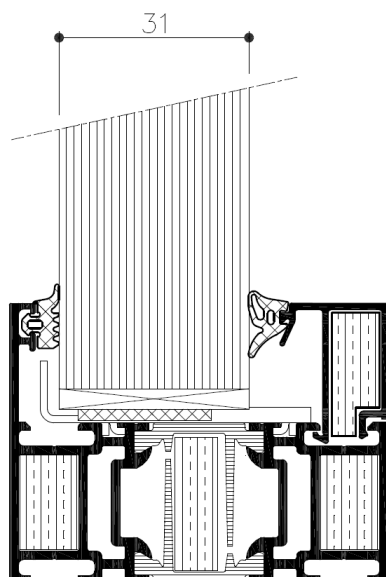

Joints between adjacent panes should be 4 mm wide and sealed with 2 pieces of 2 x 21 mm wide Kerafix FXL 200 intumescent strips and top sealed with Dow Corning 'DC 895' sealant.

Table 112 – Maximum Permitted Glass Dimensions		
Max. Width (mm)	Max. Height (mm)	Max. Area (m <sup>2</sup> )
1500 (at 3000 high)	3000 (at 1500 wide)	4.5

## CERTIFICATE No CF811

### Vetrotech Saint-Gobain International AG

#### Contraflam Structure 60 Glass (33 mm) in butt jointed steel framed screens for periods of 60 minutes integrity and insulation

The glass shall be installed into a previously tested or CERTIFIRE approved framing system (which is covered appropriately by test or assessment evidence) using pressure plate glazing, screw-fixed or clip-on retaining beads, see examples below. The glass shall be glazed into the screen as described in the table below and set on non-combustible setting blocks to determine the correct edge cover.

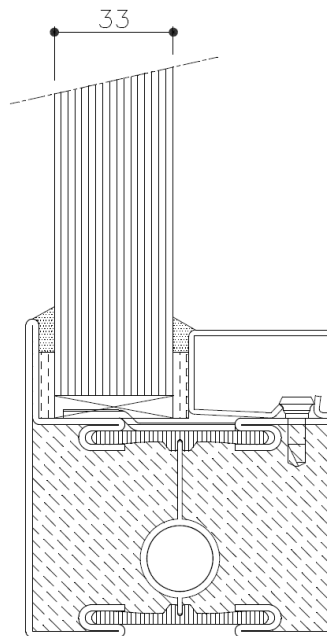

Joints between adjacent panes should be 4 mm wide and sealed with 2 pieces of 2 x 23 mm wide Kerafix FXL 200 intumescent strips and top sealed with Dow Corning 'DC 895' sealant.

Table 113 – Maximum Permitted Glass Dimensions		
Max. Width (mm)	Max. Height (mm)	Max. Area (m <sup>2</sup> )
1680 (at 2690 high)	3480 (at 1300 wide)	4.52

## CERTIFICATE No CF811

### Vetrotech Saint-Gobain International AG

**Contraflam Structure 60 Glass (33 mm) in butt jointed timber framed screens for periods of 60 minutes integrity and insulation**

The glass shall be glazed utilising the following basic specification:

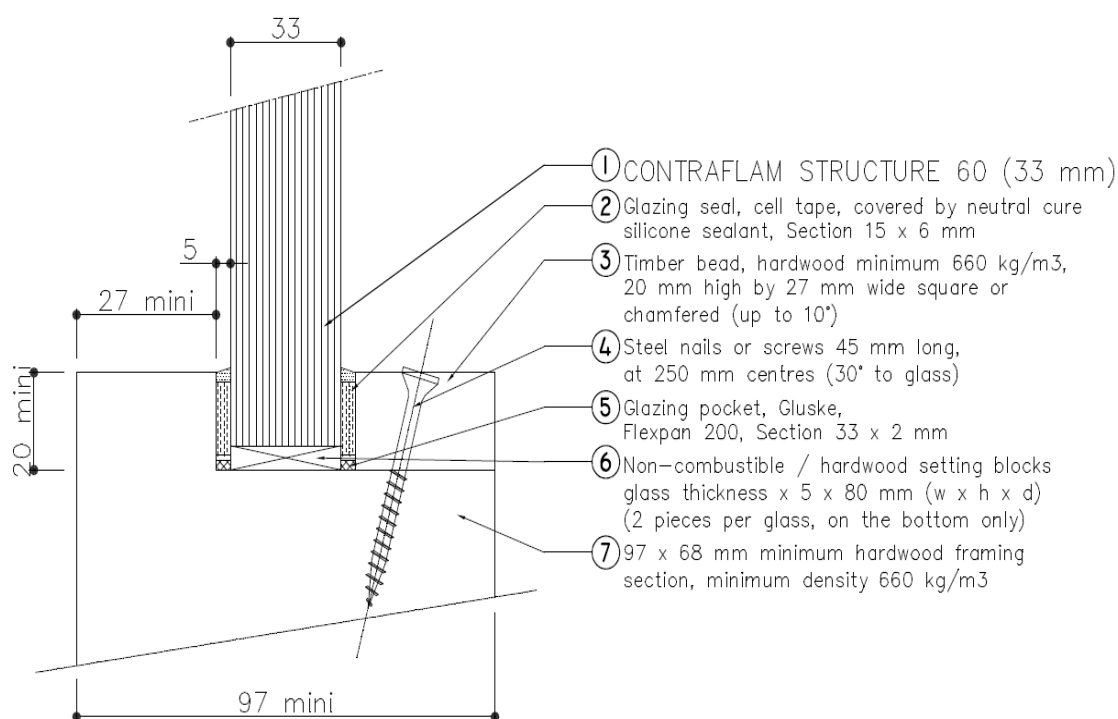

Joints between adjacent panes should be 4 mm wide and sealed with 2 pieces of 2 x 23 mm wide Kerafix FXL 200 intumescent strips and top sealed with Dow Corning 'DC 895' sealant.

Max. Width (mm)	Max. Height (mm)	Max. Area (m <sup>2</sup> )
1680 (at 2690 high)	3480 (at 1300 wide)	4.52

## CERTIFICATE No CF811

### Vetrotech Saint-Gobain International AG

**Contraflam Structure 60 Glass (33 mm) in butt jointed Schueco ADS 80 FR60 or Aluprof MB-78EI aluminium framed screens for periods of 60 minutes integrity and insulation**

The glass shall be installed into the Schueco ADS 80 FR60 system or the Aluprof MB-78EI system (each of which shall be covered appropriately by test or assessment evidence). The below drawing is an example only.

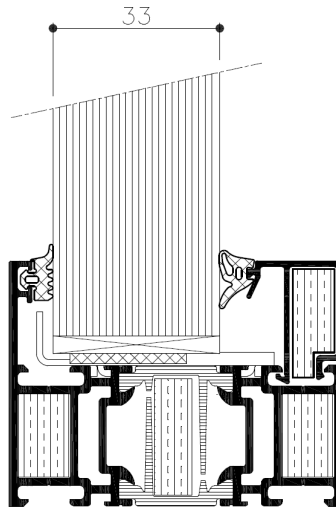

Joints between adjacent panes should be 4 mm wide and sealed with 2 pieces of 2 x 23 mm wide Kerafix FXL 200 intumescent strips and top sealed with Dow Corning 'DC 895' sealant.

System	Max. Width (mm)	Max. Height (mm)	Max. Area (m <sup>2</sup> )
Schueco ADS 80 FR60	1740 (at 3000 high)	3480 (at 1500 wide)	5.22
Aluprof MB-78EI	1620 (at 3000 high)	3240 (at 1500 wide)	4.86

## CERTIFICATE No CF811

### Vetrotech Saint-Gobain International AG

#### Contraflam Structure 60 Glass (41 mm) in butt jointed steel framed screens for periods of 60 minutes integrity and insulation

The glass shall be installed into a previously tested or CERTIFIRE approved framing system (which is covered appropriately by test or assessment evidence) using pressure plate glazing, screw-fixed or clip-on retaining beads, see examples below. The glass shall be glazed into the screen as described in the table below and set on non-combustible setting blocks to determine the correct edge cover.

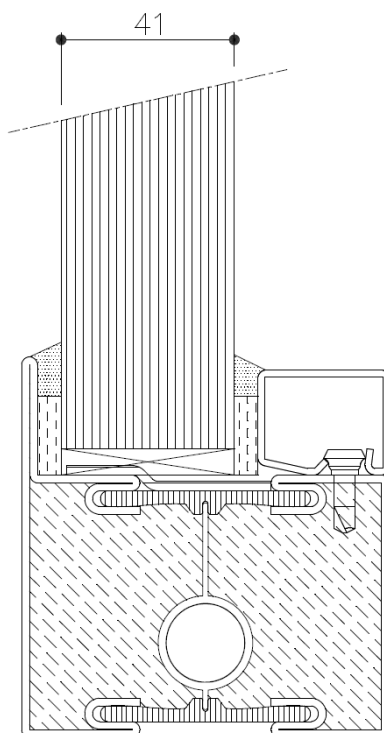

Joints between adjacent panes should be 4 mm wide and sealed with 2 pieces of 2 x 31 mm wide Kerafix FXL 200 intumescent strips and top sealed with Dow Corning 'DC 895' sealant.

Table 116 – Maximum Permitted Glass Dimensions		
Max. Width (mm)	Max. Height (mm)	Max. Area (m <sup>2</sup> )
1534 (at 3750 high)	3900 (at 1474 wide)	5.75

## CERTIFICATE No CF811

### Vetrotech Saint-Gobain International AG

**Contraflam Structure 60 Glass (41 mm) in butt jointed timber framed screens for periods of 60 minutes integrity and insulation**

The glass shall be glazed utilising the following basic specification:

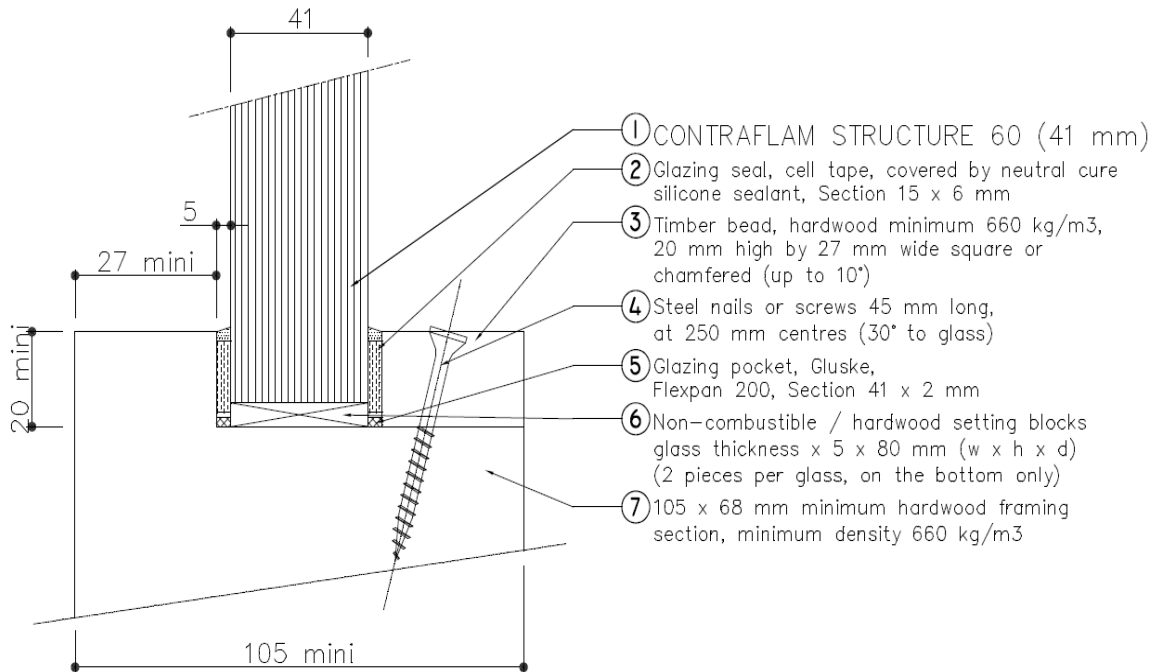

Joints between adjacent panes should be 4 mm wide and sealed with 2 pieces of 2 x 31 mm wide Kerafix FXL 200 intumescent strips and top sealed with Dow Corning 'DC 895' sealant.

Max. Width (mm)	Max. Height (mm)	Max. Area (m <sup>2</sup> )
1534 (at 3750 high)	3900 (at 1474 wide)	5.75

## CERTIFICATE No CF811

### Vetrotech Saint-Gobain International AG

**Contraflam Structure 60 Glass (41 mm) in butt jointed Schueco ADS 80 FR60 or Aluprof MB-78EI aluminium framed screens for periods of 60 minutes integrity and insulation**

The glass shall be installed into the Schueco ADS 80 FR60 system or the Aluprof MB-78EI system (each of which shall be covered appropriately by test or assessment evidence). The below drawing is an example only.

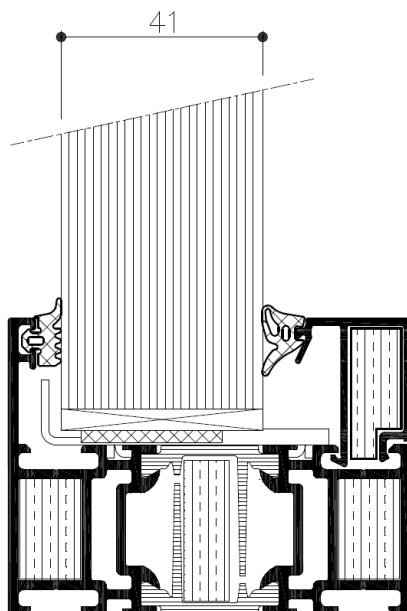

Joints between adjacent panes should be 4 mm wide and sealed with 2 pieces of 2 x 31 mm wide Kerafix FXL 200 intumescent strips and top sealed with Dow Corning 'DC 895' sealant.

**Table 118 – Maximum Permitted Glass Dimensions**

System	Max. Width (mm)	Max. Height (mm)	Max. Area (m <sup>2</sup> )
Schueco ADS 80 FR60	1740 (at 3000 high)	3480 (at 1500 wide)	5.22
Aluprof MB-78EI	1620 (at 3000 high)	3240 (at 1500 wide)	4.86

## CERTIFICATE No CF811

### Vetrotech Saint-Gobain International AG

#### Contraflam Structure 60 Glass

#### Installation Instruction

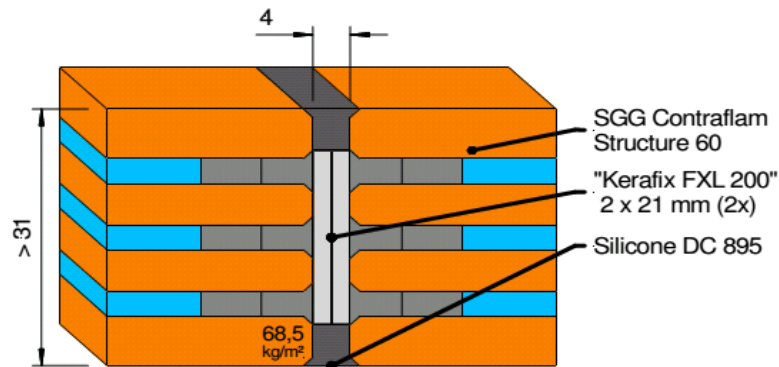

- **Clean the glass edges to be sealed**
  - remove excess polysulphide by razor blade / steel wool "00"
  - clean glass edge with: white spiritus or Dow Corning R41 (do not use other cleaning agents or solvents!)
- **Stick „Kerafix FXL 200“ on vertical glass edges**  
make sure it is centered!
- **Install glass panes and adjust to parallel position**  
glasses can be adjusted to parallel position by some continuous pressure in direction of the glass surfaces
- **Inject silicone "Dow Corning 895" into the joint, remove excessive material and smooth the joint as usual**

## CERTIFICATE No CF811

### Vetrotech Saint-Gobain International AG

#### Contraflam Structure 60 Corner Glass (31 mm) in butt jointed steel framed screens with 90° corner joints for periods of 60 minutes integrity and insulation

The glass shall be installed into a previously tested or CERTIFIRE approved framing system (which is covered appropriately by test or assessment evidence) using pressure plate glazing, screw-fixed or clip-on retaining beads, see examples below. The glass shall be glazed into the screen as described in the table below and set on non-combustible setting blocks to determine the correct edge cover.

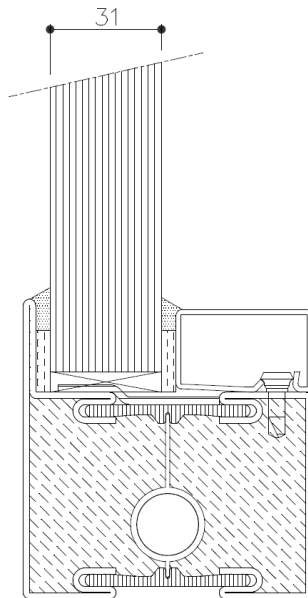

Joints between adjacent panes for 90° joints should be 4 mm wide and sealed with 2 pieces of 2 x 40 mm wide Kerafix FXL 200 intumescent strips and top sealed with Dow Corning 'DC 895' sealant.

Table 119 – Maximum Permitted Glass Dimensions		
Max. Width (mm)	Max. Height (mm)	Max. Area (m <sup>2</sup> )
1500 (at 2865 high)	3000 (at 1250 wide)	4.3

## CERTIFICATE No CF811

### Vetrotech Saint-Gobain International AG

#### Contraflam Structure 60 Corner Glass (33 mm) in butt jointed steel framed screens with 90° corner joints for periods of 60 minutes integrity and insulation

The glass shall be installed into a previously tested or CERTIFIRE approved framing system (which is covered appropriately by test or assessment evidence) using pressure plate glazing, screw-fixed or clip-on retaining beads, see examples below. The glass shall be glazed into the screen as described in the table below and set on non-combustible setting blocks to determine the correct edge cover.

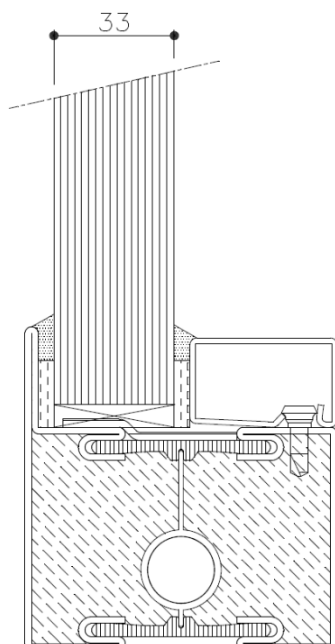

Joints between adjacent panes for 90° joints should be 4 mm wide and sealed with 2 pieces of 2 x 40 mm wide Kerafix FXL 200 intumescent strips and top sealed with Dow Corning 'DC 895' sealant.

Table 120 – Maximum Permitted Glass Dimensions		
Max. Width (mm)	Max. Height (mm)	Max. Area (m <sup>2</sup> )
1500 (at 2886 high)	3438 (at 1259 wide)	4.33

## CERTIFICATE No CF811 Vetrotech Saint-Gobain International AG

### Contraflam Structure 60 Corner Glass

#### Installation Instruction

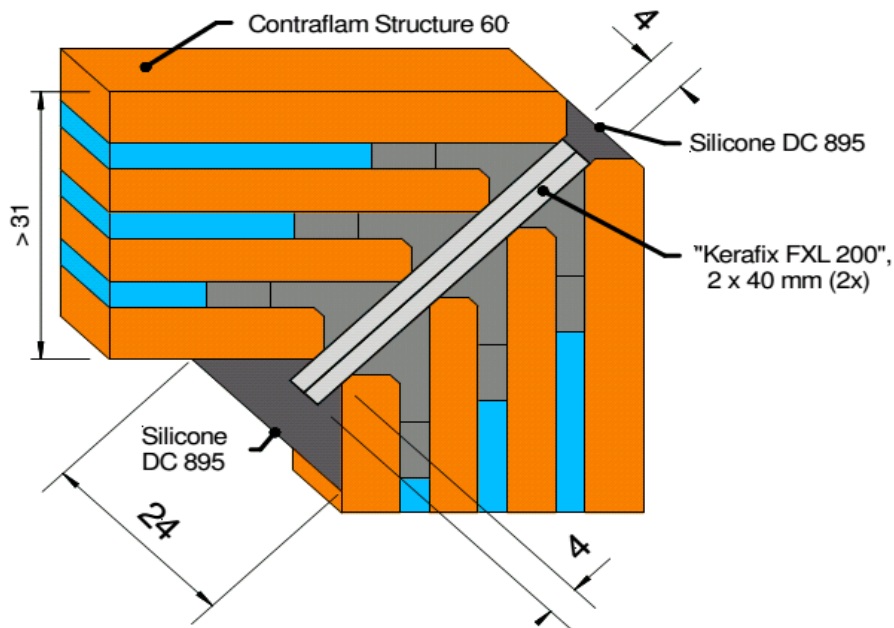

- **Clean the glass edges to be sealed**
  - remove excess polysulphide by razor blade / steel wool "00"
  - clean glass edge with: white spiritus or Dow Corning R41 (do not use other cleaning agents or solvents!)
- **Stick „Kerafix FXL 200“ on vertical glass edges**  
make sure to have 4 mm projecting
- **Install glass panes and adjust to correct position**  
glasses can be adjusted to correct position by some continuous pressure in direction of the glass surfaces
- **Inject silicone "Dow Corning 895" into the joint, remove excessive material and smooth the joint as usual**

## CERTIFICATE No CF811

### Vetrotech Saint-Gobain International AG

#### Contraflam Structure 60 IGU Glass in butt jointed steel framed screens for periods of 60 minutes integrity and insulation

The glass shall be installed into a previously tested or CERTIFIRE approved framing system (which is covered appropriately by test or assessment evidence) using pressure plate glazing, screw-fixed or clip-on retaining beads, see examples below. The glass shall be glazed into the screen as described in the table below and set on non-combustible setting blocks to determine the correct edge cover.

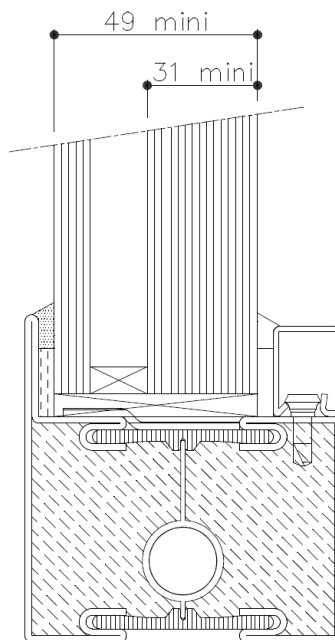

Joints between adjacent panes for internal application should be 4 mm wide and sealed with 2 pieces of 2 x (xx\*) mm wide Kerafix FXL 200 intumescent strips or for external application Flextrem 100 with 2 pieces of 2 x (xx\*) mm and top sealed with Dow Corning 'DC 895' sealant.

xx\* = Overall glass thickness – 10 mm

Table 121 – Maximum Permitted Glass Dimensions		
Max. Width (mm)	Max. Height (mm)	Max. Area (m <sup>2</sup> )
1800 (at 3000 high)	3600 (at 1500 wide)	5.4

## CERTIFICATE No CF811

### Vetrotech Saint-Gobain International AG

#### Contraflam Structure 60 IGU Glass in butt jointed timber framed screens for periods of 60 minutes integrity and insulation

The glass shall be glazed utilising the following basic specification:

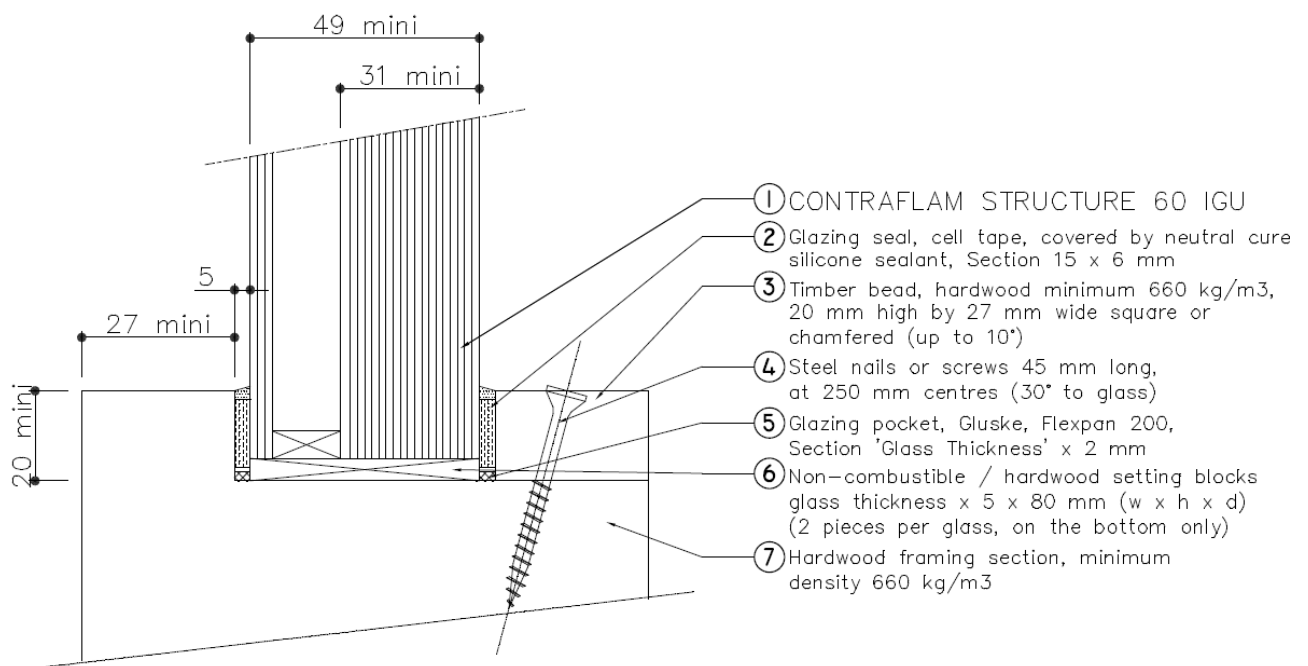

Joints between adjacent panes for internal application should be 4 mm wide and sealed with 2 pieces of 2 x (xx\*) mm wide Kerafix FXL 200 intumescent strips or for external application Flextrem 100 with 2 pieces of 2 x (xx\*) mm and top sealed with Dow Corning 'DC 895' sealant.

xx\* = Overall glass thickness – 10 mm

Max. Width (mm)	Max. Height (mm)	Max. Area (m <sup>2</sup> )
1800 (at 3000 high)	3600 (at 1500 wide)	5.4

## CERTIFICATE No CF811

### Vetrotech Saint-Gobain International AG

#### Contraflam Structure 60 IGU Glass in butt jointed Reynaers CS 77-FP aluminium framed screens for periods of 60 minutes integrity and insulation

The glass shall be installed into the Reynaers CS 77-FP insulated system (which shall be covered appropriately by test or assessment evidence).

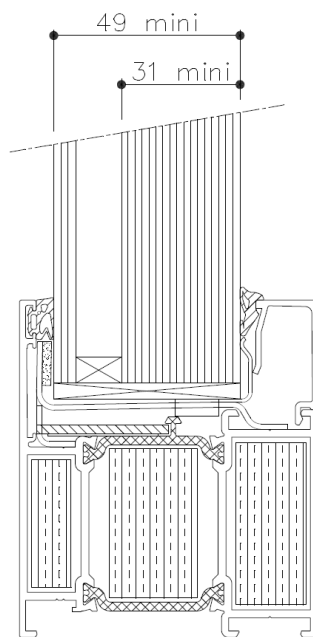

Joints between adjacent panes for internal and external applications should be 6 mm ( $\pm 1$  mm) wide and sealed with 2 pieces of 2 x ( $xx^*$ ) mm wide Kerafix Flextrem 100 and top sealed with Dow Corning 'DC 895' sealant.

$xx^*$  = Overall glass thickness – 10 mm

Table 123 – Maximum Permitted Glass Dimensions		
Max. Width (mm)	Max. Height (mm)	Max. Area (m <sup>2</sup> )
1800 (at 3000 high)	3600 (at 1500 wide)	5.4

## CERTIFICATE No CF811

### Vetrotech Saint-Gobain International AG

#### Contraflam Structure 60 IGU Glass

#### Installation Instruction

#### For interior use only!

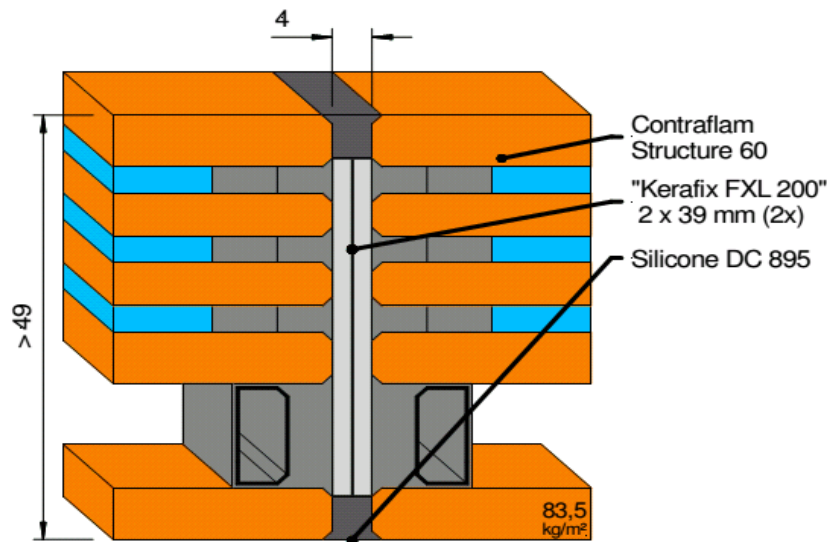

- **Clean the glass edges to be sealed**
  - remove excess polysulphide by razor blade / steel wool "00"
  - clean glass edge with: white spiritus or Dow Corning R41 (do not use other cleaning agents or solvents!)
- **Stick „Kerafix FXL 200“ on vertical glass edges**  
make sure it is centered!
- **Install glass panes and adjust to parallel position**  
glasses can be adjusted to parallel position by some continuous pressure in direction of the glass surfaces
- **Inject silicone "Dow Corning 895" into the joint, remove excessive material and smooth the joint as usual**

## CERTIFICATE No CF811

### Vetrotech Saint-Gobain International AG

#### Contraflam Structure 60 IGU Glass

#### Installation Instruction

#### For interior and exterior use

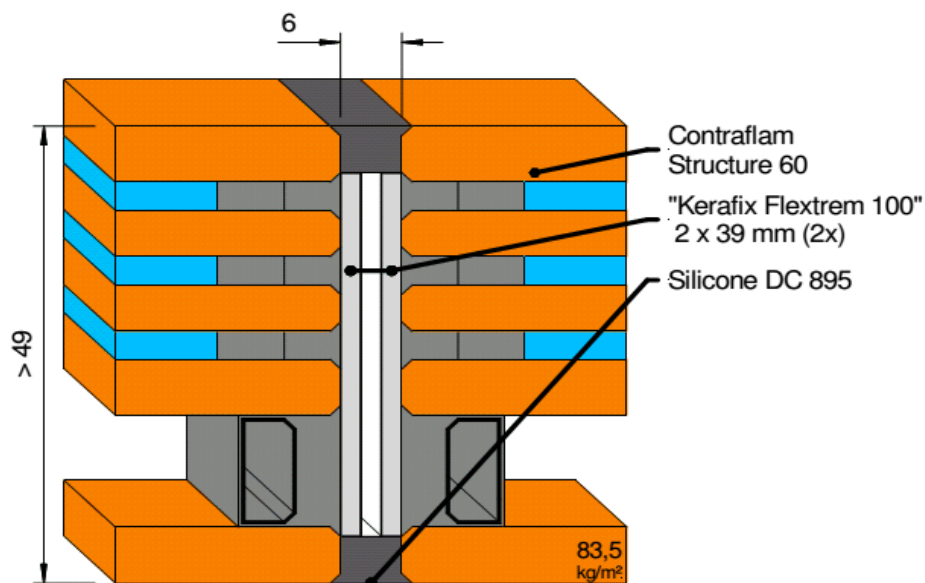

- **Clean the glass edges to be sealed**
  - remove excess polysulphide by razor blade / steel wool "00"
  - clean glass edge with: white spiritus or Dow Corning R41 (do not use other cleaning agents or solvents!)
- **Stick „Kerafix Flextrem 100“ on vertical glass edges**  
make sure it is centered!
- **Install glass panes and adjust to parallel position**  
glasses can be adjusted to parallel position by some continuous pressure in direction of the glass surfaces
- **Inject silicone "Dow Corning 895" into the joint, remove excessive material and smooth the joint as usual**

## CERTIFICATE No CF811

### Vetrotech Saint-Gobain International AG

#### Contraflam Structure 90 Glass (45 mm minimum) in butt jointed steel framed screens for periods of 90 minutes integrity and insulation

The glass shall be installed into a previously tested or CERTIFIRE approved framing system (which is covered appropriately by test or assessment evidence) using pressure plate glazing, screw-fixed or clip-on retaining beads, see examples below. The glass shall be glazed into the screen as described in the table below and set on non-combustible setting blocks to determine the correct edge cover.

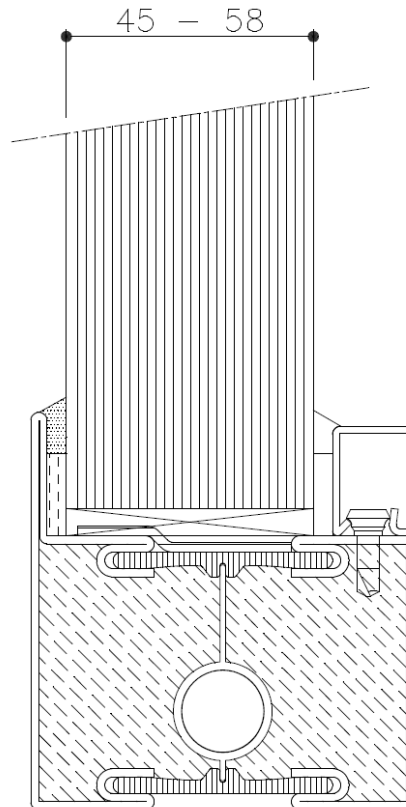

Joints between adjacent panes for internal application should be 4 mm wide and sealed with 2 pieces of 2 x (xx\*) mm wide Kerafix FXL 200 intumescent strips and top sealed with Dow Corning 'DC 895' sealant.

xx\* = Overall glass thickness – 10 mm

Allowable dimensions on next page.

Page 151 of 194 Signed  
E014243-3, E014243-4



Issued: 2<sup>nd</sup> July 2025  
Valid to: 1<sup>st</sup> July 2030

EWC-QU-FT-733 (Issue 2)

## CERTIFICATE No CF811

### Vetrotech Saint-Gobain International AG

Contraflam Structure 90 Glass (45 mm minimum) in butt jointed steel framed screens for periods of 90 minutes integrity and insulation (cont)

Table 124 – Maximum Permitted Glass Dimensions CFS 90 (45 mm minimum)		
Max. Width (mm)	Max. Height (mm)	Max. Area (m <sup>2</sup> )
1500 (at 3000 high)	3000 (at 1500 wide)	4.5
Table 125 - Maximum Permitted Glass Dimensions CFS 90 (48 mm minimum)		
Max. Width (mm)	Max. Height (mm)	Max. Area (m <sup>2</sup> )
1800 (at 3500 high)	3500 (at 1800 wide)	6.3



## CERTIFICATE No CF811

### Vetrotech Saint-Gobain International AG

#### Contraflam Structure 90 Glass

#### Installation Instruction

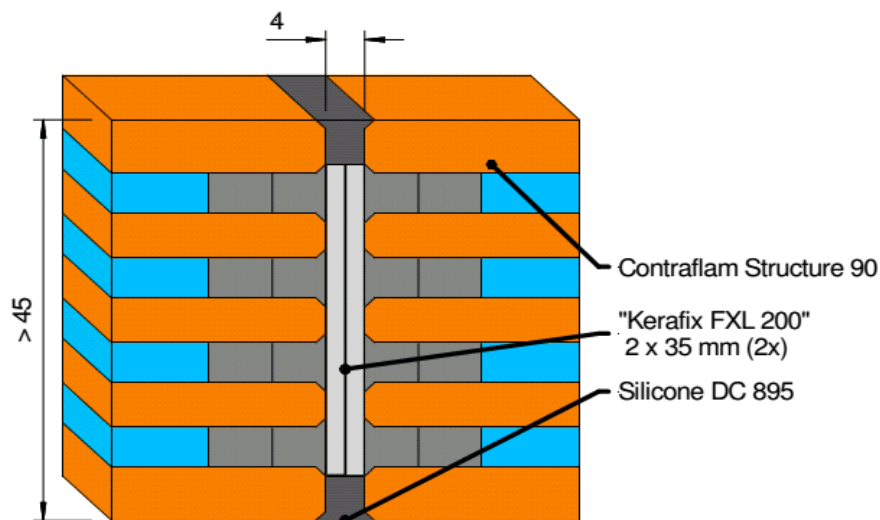

- **Clean the glass edges to be sealed**
  - remove excess polysulphide by razor blade / steel wool "00"
  - clean glass edge with: white spiritus or Dow Corning R41 (do not use other cleaning agents or solvents!)
- **Stick „Kerafix FXL 200“ on vertical glass edges**  
make sure it is centered!
- **Install glass panes and adjust to parallel position**  
glasses can be adjusted to parallel position by some continuous pressure in direction of the glass surfaces
- **Inject silicone "Dow Corning 895" into the joint, remove excessive material and smooth the joint as usual**

## CERTIFICATE No CF811

### Vetrotech Saint-Gobain International AG

#### Contraflam Structure 120 Glass (73 mm – 79 mm) in butt jointed steel framed screens for periods of 120 minutes integrity and insulation

The glass shall be installed into a previously tested or CERTIFIRE approved framing system (which is covered appropriately by test or assessment evidence) using pressure plate glazing, screw-fixed or clip-on retaining beads, see examples below. The glass shall be glazed into the screen as described in the table below and set on non-combustible setting blocks to determine the correct edge cover.

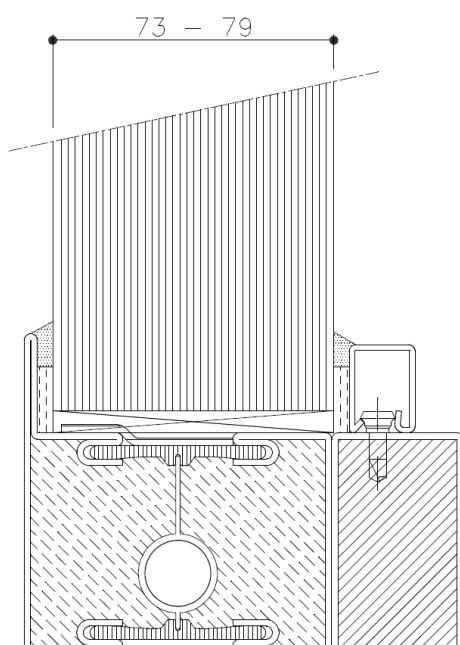

Joints between adjacent panes for internal application should be 4 mm wide and sealed with 2 pieces of 2 x (xx\*) mm wide Kerafix FXL 200 intumescent strips and top sealed with Dow Corning 'DC 895' sealant.

xx\* = Overall glass thickness – 10 mm

Table 126 – Maximum Permitted Glass Dimensions		
Max. Width (mm)	Max. Height (mm)	Max. Area (m <sup>2</sup> )
1300 (at 2646 high)	2750 (at 1250 wide)	3.44

## CERTIFICATE No CF811

### Vetrotech Saint-Gobain International AG

#### Contraflam Structure 120 Glass

#### Installation Instruction

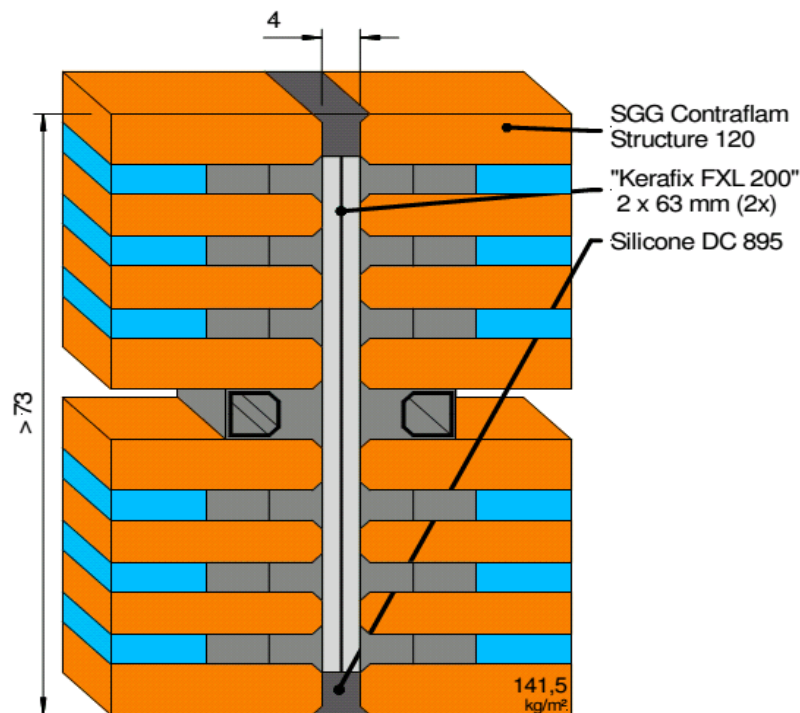

- **Clean the glass edges to be sealed**
  - remove excess polysulphide by razor blade / steel wool "00"
  - clean glass edge with: white spiritus or Dow Corning R41 (do not use other cleaning agents or solvents!)
- **Stick „Kerafix FXL 200“ on vertical glass edges**  
make sure it is centered!
- **Install glass panes and adjust to parallel position**  
glasses can be adjusted to parallel position by some continuous pressure in direction of the glass surfaces
- **Inject silicone "Dow Corning 895" into the joint, remove excessive material and smooth the joint as usual**

## CERTIFICATE No CF811

### Vetrotech Saint-Gobain International AG

#### Contraflam Structure 120-5 Glass (52 mm minimum) in butt jointed steel framed screens for periods of 120 minutes integrity and insulation

The glass shall be installed into a previously tested or CERTIFIRE approved framing system (which is covered appropriately by test or assessment evidence) using pressure plate glazing, screw-fixed or clip-on retaining beads, see examples below. The glass shall be glazed into the screen as described in the table below and set on non-combustible setting blocks to determine the correct edge cover.

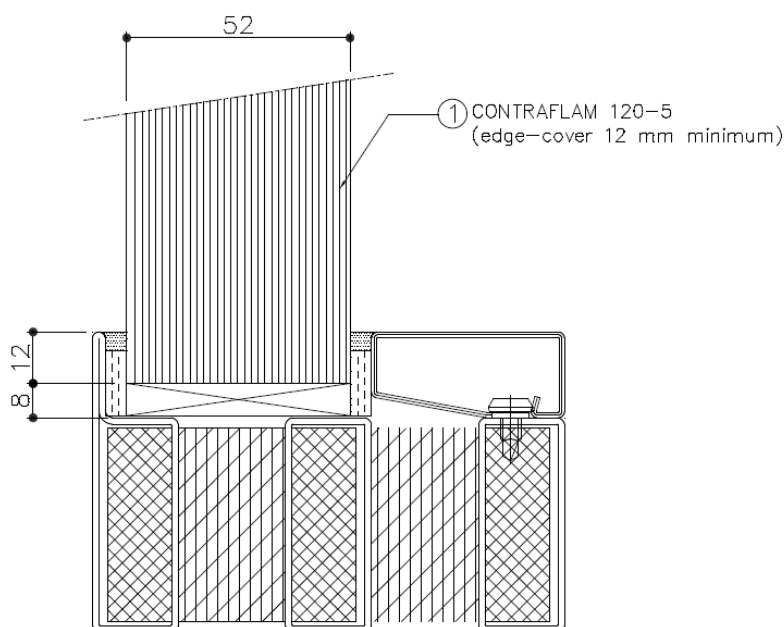

Joints between adjacent panes for internal application should be 4 mm wide and sealed with 2 pieces of 2 x (xx\*) mm wide Kerafix FXL 200 intumescent strips and top sealed with Dow Corning 'DC 895' or 'DC 995' sealant.

xx\* = Overall glass thickness – 10 mm

Table 127 – Maximum Permitted Glass Dimensions		
Max. Width (mm)	Max. Height (mm)	Max. Area (m <sup>2</sup> )
1500 (at 3000 high)	3000 (at 1500 wide)	4.50

## CERTIFICATE No CF811

### Vetrotech Saint-Gobain International AG

#### Contraflam Structure 120-5 Glass

#### Installation Instruction

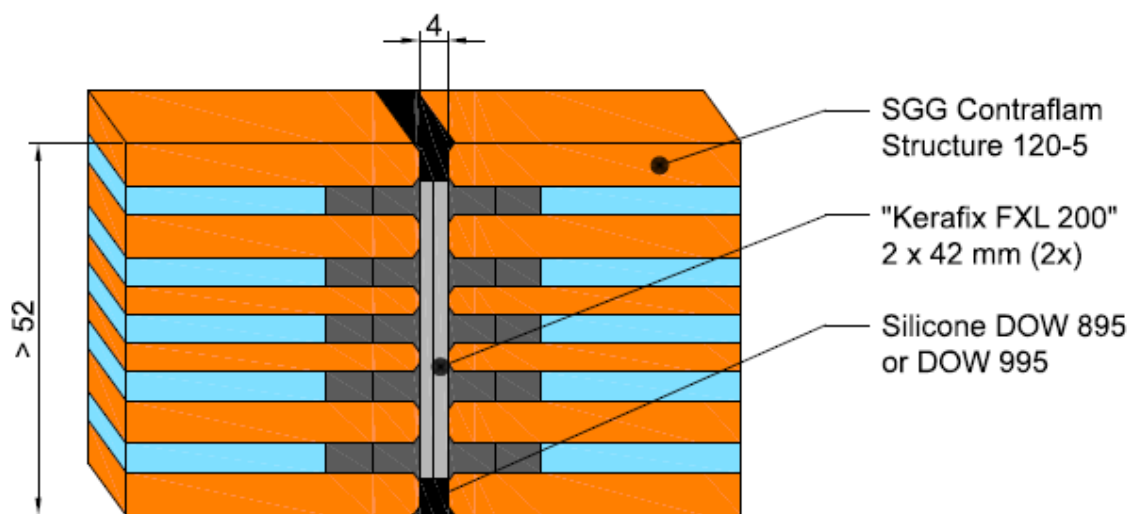

- **Clean the glass edges to be sealed**
  - remove excess polysulphide by razor blade / steel wool "00"
  - clean glass edge with white spirit or Dow Corning R41
  - (do not use other cleaning agents or solvents!)
  -
- **Stick "Kerafix FXL 200" on vertical glass edges**
  - make sure it is centered!
  -
- **Install glass panes and adjust to parallel position**
  - glass can be adjusted to parallel position by some continuous pressure in direction of the glass surfaces
  -
- **Inject silicone "Dowsil (DOW) 895 or 995" into the joint, remove excessive material and smooth the joint as usual**

## CERTIFICATE No CF811

### Vetrotech Saint-Gobain International AG

#### Contraflam Door Lite Glass in steel doors for periods of 90 minutes integrity and 15 minutes insulation

The glass shall be glazed within a previously fire tested or CERTIFIRE approved steel based doorset (which is covered appropriately by test or assessment evidence) using screw-fixed or clip-on retaining beads. The glass shall be glazed into the doorset as described below and set on non-combustible setting blocks to determine the correct edge cover.

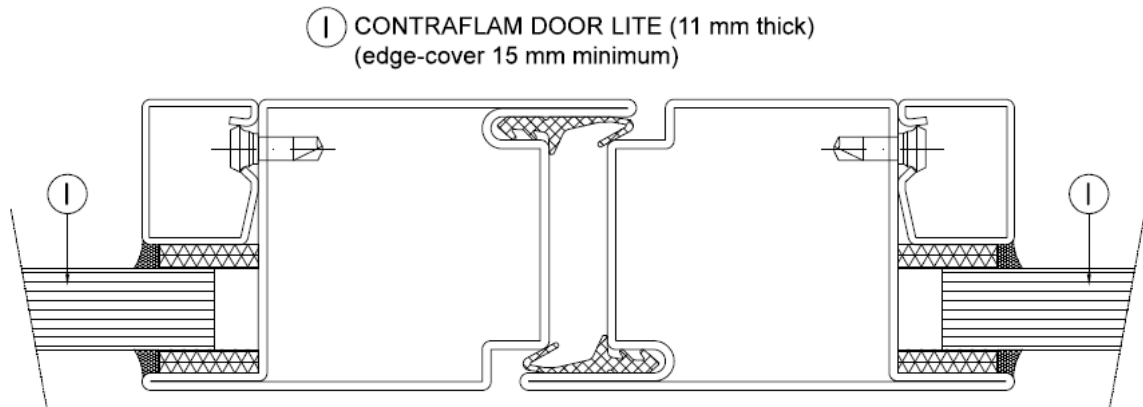

The doorset shall have test evidence or be CERTIFIRE approved for the inclusion of apertures of the proposed dimensions. This Certificate of Approval relates to the sizes of Contraflam Door Lite glass shown in the table below, when used in conjunction with the above system:

Table 128 – Maximum Permitted Glass Dimensions		
Max. Width (mm)	Max. Height (mm)	Max. Area (m <sup>2</sup> )
1100 (at 2197 high)	2200 (at 1045 wide)	2.87

## CERTIFICATE No CF811

### Vetrotech Saint-Gobain International AG

#### Contraflam Door Lite Glass in steel doors for periods of 120 minutes integrity and 15 minutes insulation

The glass shall be glazed within a previously fire tested or CERTIFIRE approved steel based doorset (which is covered appropriately by test or assessment evidence) using screw-fixed or clip-on retaining beads. The glass shall be glazed into the doorset as described below and set on non-combustible setting blocks to determine the correct edge cover.

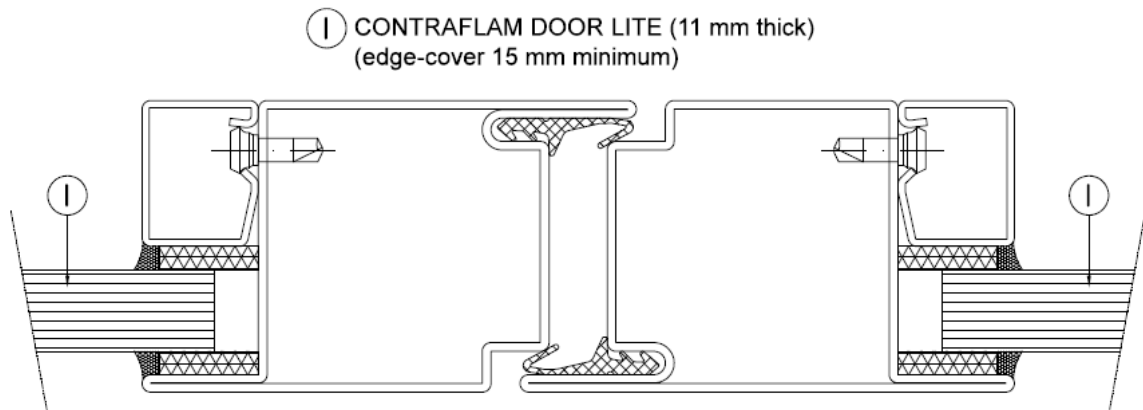

The doorset shall have test evidence or be CERTIFIRE approved for the inclusion of apertures of the proposed dimensions. This Certificate of Approval relates to the sizes of Contraflam Door Lite glass shown in the table below, when used in conjunction with the above system:

<b>Table 129 – Maximum Permitted Glass Dimensions</b>		
<b>Max. Width (mm)</b>	<b>Max. Height (mm)</b>	<b>Max. Area (m<sup>2</sup>)</b>
1045 (at 2197 high)	2197 (at 1045 wide)	2.29

## CERTIFICATE No CF811

### Vetrotech Saint-Gobain International AG

#### Contraflam Door Lite Glass in steel doors for periods of 180 minutes integrity

The glass shall be glazed within a previously fire tested or CERTIFIRE approved steel based doorset (which is covered appropriately by test or assessment evidence) using screw-fixed or clip-on retaining beads. The glass shall be glazed into the doorset as described below and set on non-combustible setting blocks to determine the correct edge cover.

① CONTRAFLAM DOOR LITE (11 mm thick)  
(edge-cover 15 mm minimum)

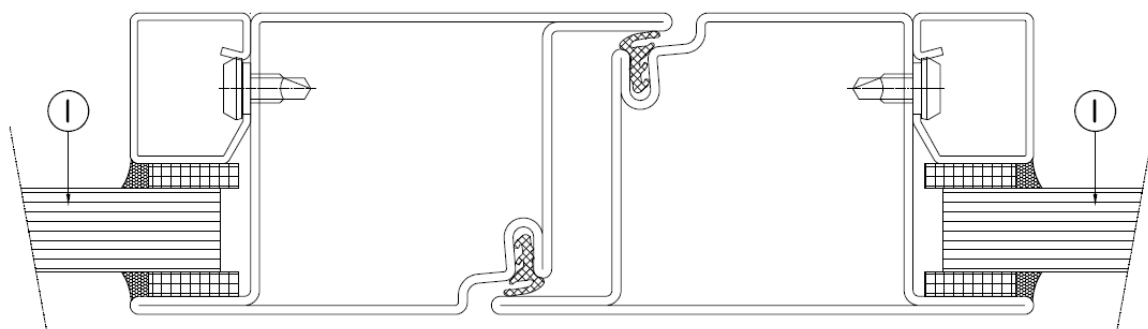

The doorset shall have test evidence or be CERTIFIRE approved for the inclusion of apertures of the proposed dimensions. This Certificate of Approval relates to the sizes of Contraflam Door Lite glass shown in the table below, when used in conjunction with the above system:

Table 130 – Maximum Permitted Glass Dimensions		
Max. Width (mm)	Max. Height (mm)	Max. Area (m <sup>2</sup> )
934 (at 2025 high)	2025 (at 934 wide)	1.89

Page 160 of 194 Signed  
E014243-3, E014243-4

Issued: 2<sup>nd</sup> July 2025  
Valid to: 1<sup>st</sup> July 2030

EWC-QU-FT-733 (Issue 2)

## CERTIFICATE No CF811

### Vetrotech Saint-Gobain International AG

#### Contraflam Door Lite Glass in timber doors for periods of 30 minutes integrity and 15 minutes insulation

The glass shall be glazed within a previously fire tested or CERTIFIRE approved timber based doorset (which is covered appropriately by test or assessment evidence). The glass shall be set on non-combustible setting blocks to determine the correct edge cover.

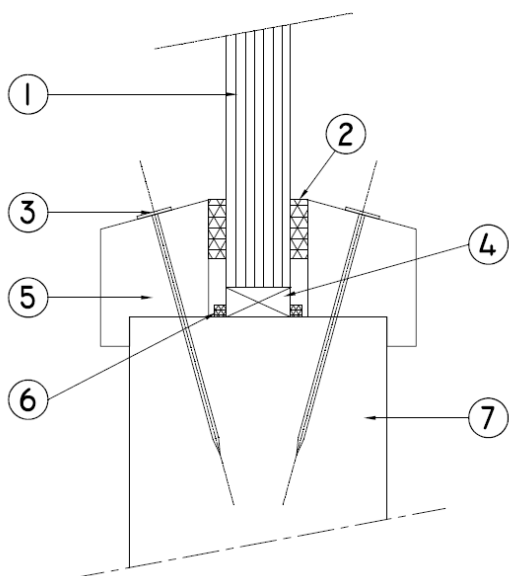

- ① CONTRAFLAM DOOR LITE (11 mm thick)  
(edge-cover 15 mm)
- ② Mann McGowan Pyroglaze 30 Tape 10 x 3 mm
- ③ Steel pins or screws 40 mm long,  
at 150 mm centres
- ④ Non-combustible / hardwood setting blocks  
glass thickness x 5 x 80 mm (w x h x d)  
(2 pieces per glass, on the bottom only)
- ⑤ 25 x 18.5 mm (h x w) hardwood glazing beads  
minimum density 655 kg/m<sup>3</sup> (including 5 x 5 mm  
(h x w) bolection with approximately 20° chamfer)
- ⑥ Glazing pocket liner, Mann McGowan  
Pyrostrip 300 SA, Section 15 x 2 mm
- ⑦ Nominally 44 mm thick FD30 door leaf

The doorset shall have test evidence or be CERTIFIRE approved for the inclusion of apertures of the proposed dimensions. This Certificate of Approval relates to the sizes of Contraflam Door Lite glass shown in the table below, when used in conjunction with the above system:

Table 131 – Maximum Permitted Glass Dimensions		
Max. Width (mm)	Max. Height (mm)	Max. Area (m <sup>2</sup> )
1060 (at 1976 high)	2094 (at 1000 wide)	2.09

## CERTIFICATE No CF811

### Vetrotech Saint-Gobain International AG

#### Contraflam Door Lite Glass in timber doors for periods of 90 minutes integrity and 15 minutes insulation

The glass shall be glazed within a previously fire tested or CERTIFIRE approved timber based doorset (which is covered appropriately by test or assessment evidence). The glass shall be set on non-combustible setting blocks to determine the correct edge cover.

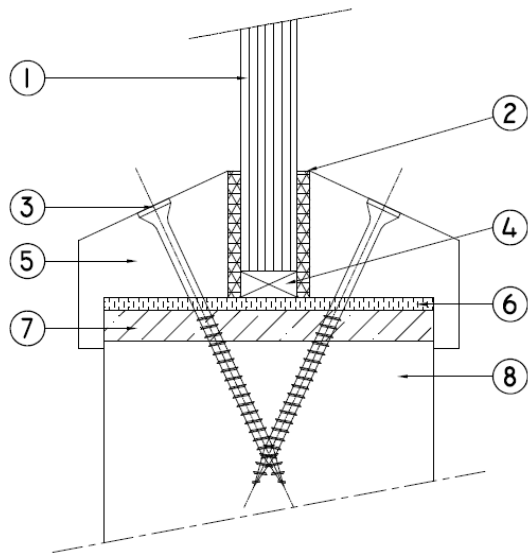

- ① CONTRAFLAM DOOR LITE (11 mm thick) (edge-cover 20 mm)
- ② Sealmaster FireGlaze tape 25 x 2.5 mm
- ③ No.8 x 3" long steel screws at 150 mm centres (25° to glass)
- ④ Non-combustible / hardwood setting blocks glass thickness x 5 x 25 mm (d x h x w) (2 pieces per glass, on the bottom only)
- ⑤ 35 x 29 mm (h x w) sapele glazing beads (including 10 x 5 mm (h x w) bolection with 25° chamfer)
- ⑥ Glazing pocket liner, Sealmaster FireGlaze Tape 64 x 2.5 mm
- ⑦ Sapele aperture lining strip 64 x 6 mm, affixed using PU adhesive and steel pins 40 x 1.6 mm at 150mm centres
- ⑧ Nominally 64 mm thick FD90 door leaf

The doorset shall have test evidence or be CERTIFIRE approved for the inclusion of apertures of the proposed dimensions. This Certificate of Approval relates to the sizes of Contraflam Door Lite glass shown in the table below, when used in conjunction with the above system:

Max. Width (mm)	Max. Height (mm)	Max. Area (m <sup>2</sup> )
288 (at 1600 high)	1840 (at 250 wide)	0.46

## CERTIFICATE No CF811

### Vetrotech Saint-Gobain International AG

#### Contraflam Door Lite Glass in timber doors for periods of 90 minutes integrity and 15 minutes insulation

The glass shall be glazed within a previously fire tested or CERTIFIRE approved timber based doorset (which is covered appropriately by test or assessment evidence). The glass shall be set on non-combustible setting blocks to determine the correct edge cover.

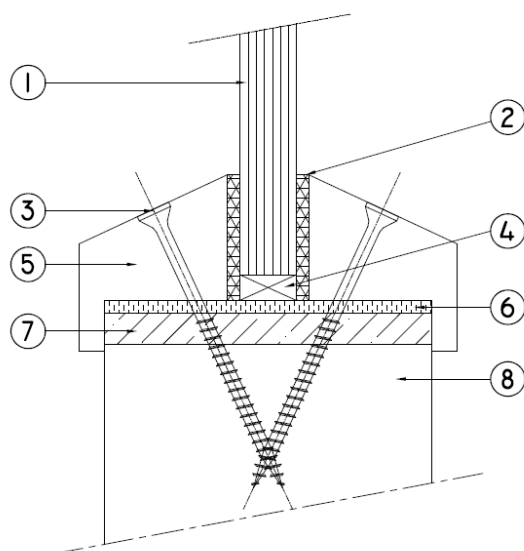

- ① CONTRAFLAM DOOR LITE (11 mm thick) (edge-cover 20 mm)
- ② Intumescent Seals ISL60 Plus tape 25 x 5.8 mm
- ③ No.8 x 3" long steel screws at 150 mm centres (25° to glass)
- ④ Non-combustible / hardwood setting blocks glass thickness x 5 x 25 mm (d x h x w) (2 pieces per glass, on the bottom only)
- ⑤ 35 x 27 mm (h x w) sapele glazing beads (including 10 x 5 mm (h x w) bolection with 25° chamfer)
- ⑥ Glazing pocket liner, Intumescent Seals Therm-A-Line Tape 63 x 2 mm
- ⑦ Sapele aperture lining strip 64 x 6 mm, affixed using PU adhesive and steel pins 40 x 1.6 mm at 150mm centres
- ⑧ Nominally 64 mm thick FD90 door leaf

The doorset shall have test evidence or be CERTIFIRE approved for the inclusion of apertures of the proposed dimensions. This Certificate of Approval relates to the sizes of Contraflam Door Lite glass shown in the table below, when used in conjunction with the above system:

Max. Width (mm)	Max. Height (mm)	Max. Area (m <sup>2</sup> )
285 (at 1600 high)	1824 (at 250 wide)	0.45

## CERTIFICATE No CF811

### Vetrotech Saint-Gobain International AG

#### Contraflam Lite 30 Glass in steel doors for periods of 30 minutes integrity

The glass shall be glazed within a previously fire tested or CERTIFIRE approved steel based doorset (which is covered appropriately by test or assessment evidence) using screw-fixed or clip-on retaining beads. The glass shall be glazed into the doorset as described below and set on non-combustible setting blocks to determine the correct edge cover.

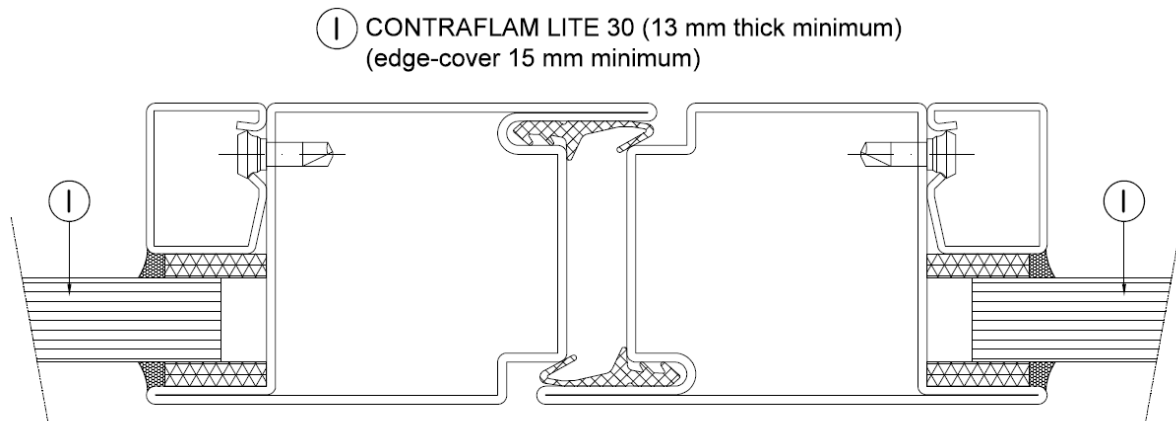

The doorset shall have test evidence or be CERTIFIRE approved for the inclusion of apertures of the proposed dimensions. This Certificate of Approval relates to the sizes of Contraflam Lite 30 glass shown in the table below, when used in conjunction with the above system:

Table 134 – Maximum Permitted Glass Dimensions		
Max. Width (mm)	Max. Height (mm)	Max. Area (m <sup>2</sup> )
1625 (at 2400 high)	3000 (at 1300 wide)	3.9
1280 (at 2448 high)	3060 (at 1024 wide)	3.13

## CERTIFICATE No CF811

### Vetrotech Saint-Gobain International AG

#### Contraflam Lite 30 Glass in timber doors for periods of 30 minutes integrity and 15 minutes insulation

The glass shall be glazed within a previously fire tested or CERTIFIRE approved timber based doorset (which is covered appropriately by test or assessment evidence). The glass shall be set on non-combustible setting blocks to determine the correct edge cover.

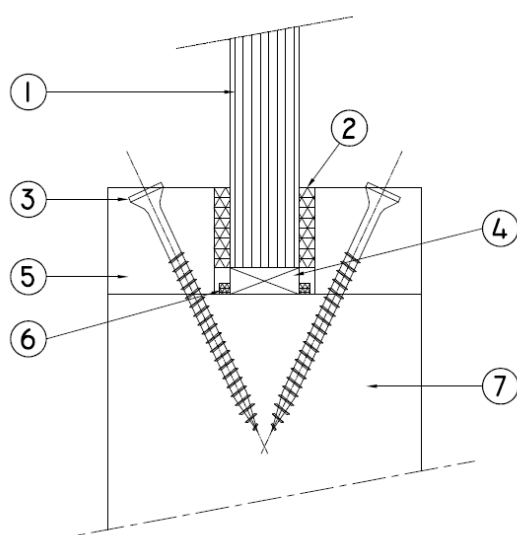

- ① CONTRAFLAM LITE 30 (13 mm thick minimum) (edge-cover 15 mm)
- ② Mann McGowan Pyrotape CF 15 x 3 mm & Neutral Silicone or Mann McGowan Pyroglaze 30 Tape 10 x 3 mm
- ③ 4.5 x 50 mm long steel screws at 150 mm centres (20° - 30° to glass)
- ④ Non-combustible / hardwood setting blocks glass thickness x 5 x 80 mm (w x h x d) (2 pieces per glass, on the bottom only)
- ⑤ 20.5 x 20 mm (h x w) hardwood glazing beads, minimum density 730 kg/m<sup>3</sup>
- ⑥ Glazing pocket liner, Mann McGowan Pyrostrip 300 SA, Section 15 x 2 mm
- ⑦ Nominally 44 mm thick FD30 door leaf

The doorset shall have test evidence or be CERTIFIRE approved for the inclusion of apertures of the proposed dimensions. This Certificate of Approval relates to the sizes of Contraflam Lite 30 glass shown in the table below, when used in conjunction with the above system:

Max. Width (mm)	Max. Height (mm)	Max. Area (m <sup>2</sup> )
1625 (at 2400 high)	3000 (at 1300 wide)	3.90

## CERTIFICATE No CF811

### Vetrotech Saint-Gobain International AG

#### Contraflam Lite 30 Glass in Schüco ADS 65 NI FR30 aluminium doors for periods of 30 minutes integrity

The glass shall be glazed within a Schüco ADS 65 NI FR30 aluminium based doorset (which is covered appropriately by test or assessment evidence) using screw-fixed or clip-on retaining beads. The glass shall be glazed into the doorset as described below and set on non-combustible setting blocks to determine the correct edge cover.

① CONTRAFLAM LITE 30 (13 mm thick minimum)  
(edge-cover 18 mm minimum)

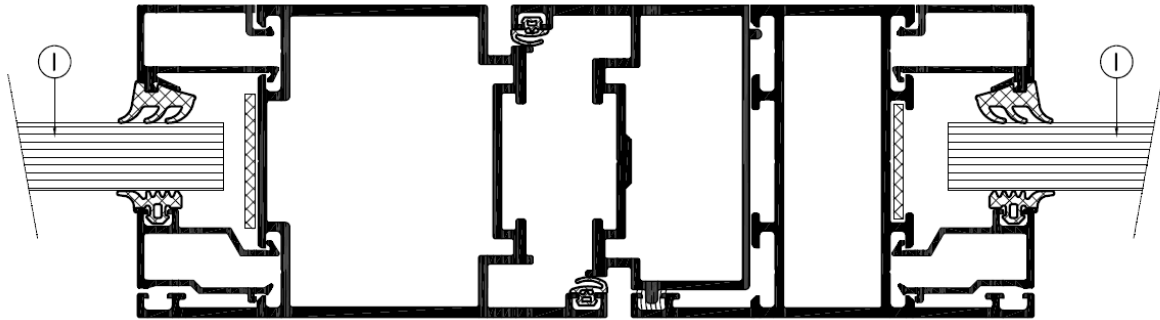

The doorset shall have test evidence or be CERTIFIRE approved for the inclusion of apertures of the proposed dimensions. This Certificate of Approval relates to the sizes of Contraflam Lite 30 glass shown in the table below, when used in conjunction with the above system:

Table 136 – Maximum Permitted Glass Dimensions		
Max. Width (mm)	Max. Height (mm)	Max. Area (m <sup>2</sup> )
1625 (at 2400 high)	3000 (at 1300 wide)	3.90

Page 166 of 194 Signed  
E014243-3, E014243-4

Issued: 2<sup>nd</sup> July 2025  
Valid to: 1<sup>st</sup> July 2030

EWC-QU-FT-733 (Issue 2)

## CERTIFICATE No CF811

### Vetrotech Saint-Gobain International AG

#### Contraflam Lite 30 Climaplus Glass in steel doors for periods of 30 minutes integrity and 15 minutes insulation

The IGU shall be glazed within a previously fire tested or CERTIFIRE approved steel based doorset (which is covered appropriately by test or assessment evidence) using screw-fixed or clip-on retaining beads. The IGU shall be glazed into the doorset as described below and set on non-combustible setting blocks to determine the correct edge cover.

① CONTRAFLAM LITE 30 CLIMAPLUS  
(edge-cover 15 mm minimum)

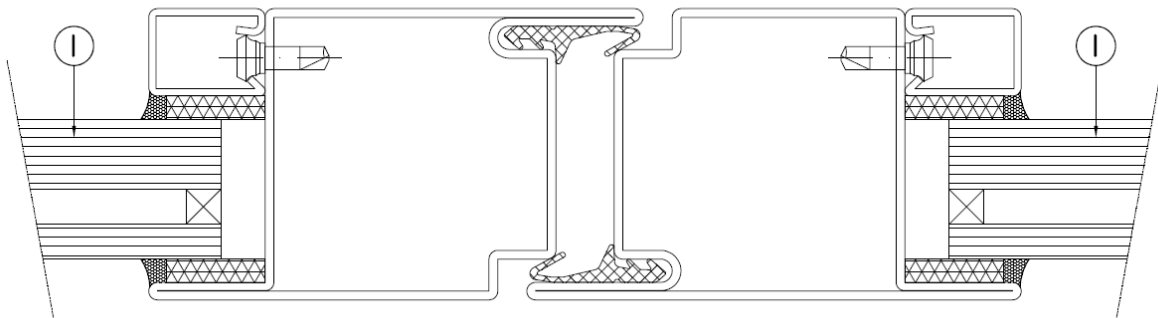

The doorset shall have test evidence or be CERTIFIRE approved for the inclusion of apertures of the proposed dimensions. This Certificate of Approval relates to the sizes of IGU's comprising at least one pane of Contraflam Lite 30 glass shown in the table below, when used in conjunction with the above system:

Table 137 – Maximum Permitted Glass Dimensions		
Max. Width (mm)	Max. Height (mm)	Max. Area (m <sup>2</sup> )
1375 (at 2477 high)	3096 (at 1100 wide)	3.40

## CERTIFICATE No CF811

### Vetrotech Saint-Gobain International AG

#### Contraflam Lite 30 Climaplus Glass in timber doors for periods of 30 minutes integrity and 15 minutes insulation

The IGU shall be glazed within a previously fire tested or CERTIFIRE approved timber based doorset (which is covered appropriately by test or assessment evidence). The IGU shall be glazed into the doorset as described below and set on non-combustible setting blocks to determine the correct edge cover.

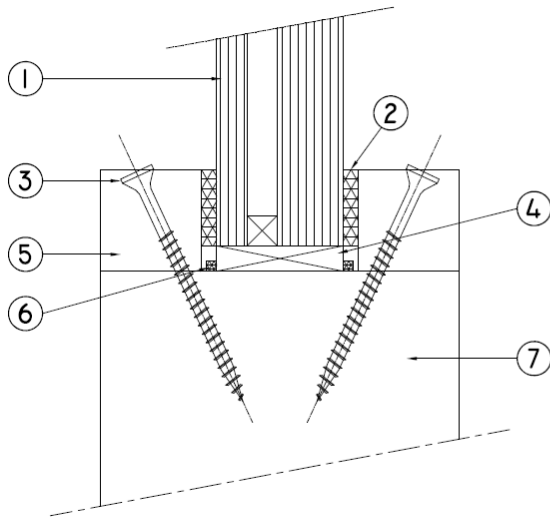

- ① CONTRAFLAM LITE 30 CLIMAPLUS (edge-cover 15 mm)
- ② Mann McGowan Pyrotape CF 15 x 3 mm & Neutral Silicone or Mann McGowan Pyroglaze 30 Tape 10 x 3 mm
- ③ 4.5 x 50 mm long steel screws at 150 mm centres (20° - 30° to glass)
- ④ Non-combustible / hardwood setting blocks glass thickness x 5 x 80 mm (w x h x d) (2 pieces per glass, on the bottom only)
- ⑤ 20.5 x 20 mm (h x w) hardwood glazing beads, minimum density 730 kg/m<sup>3</sup>
- ⑥ Glazing pocket liner, Mann McGowan Pyrostrip 300 SA, Section 15 x 2 mm
- ⑦ Nominally 44 mm thick FD30 door leaf

The doorset shall have test evidence or be CERTIFIRE approved for the inclusion of apertures of the proposed dimensions. This Certificate of Approval relates to the sizes of IGU's comprising at least one pane of Contraflam Lite 30 glass shown in the table below, when used in conjunction with the above system:

Table 138 – Maximum Permitted Glass Dimensions		
Max. Width (mm)	Max. Height (mm)	Max. Area (m <sup>2</sup> )
1108 (at 1443 high)	1775 (at 901 wide)	1.59

## CERTIFICATE No CF811

### Vetrotech Saint-Gobain International AG

#### Contraflam Lite 60 Glass in steel doors for periods of 60 minutes integrity

The glass shall be glazed within a previously fire tested or CERTIFIRE approved steel based doorset (which is covered appropriately by test or assessment evidence) using screw-fixed or clip-on retaining beads. The glass shall be glazed into the doorset as described below and set on non-combustible setting blocks to determine the correct edge cover.

① CONTRAFLAM LITE 60 (14 mm thick minimum)  
(edge-cover 15 mm minimum)

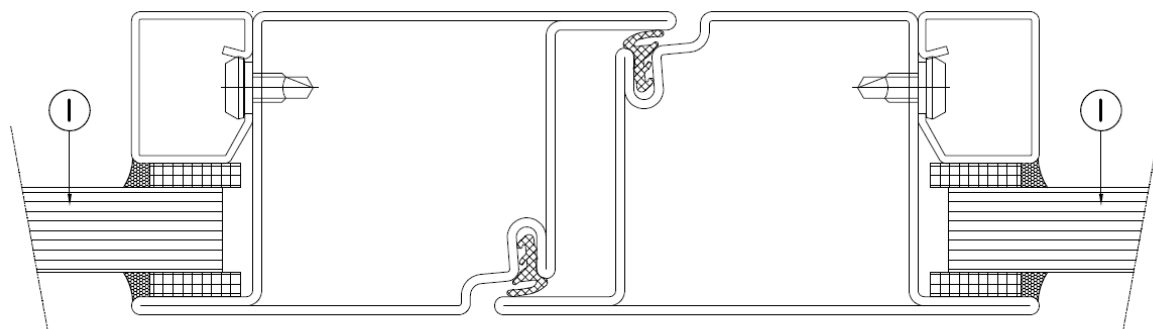

The doorset shall have test evidence or be CERTIFIRE approved for the inclusion of apertures of the proposed dimensions. This Certificate of Approval relates to the sizes of Contraflam Lite 60 glass shown in the table below, when used in conjunction with the above system:

Table 139 – Maximum Permitted Glass Dimensions		
Max. Width (mm)	Max. Height (mm)	Max. Area (m <sup>2</sup> )
1387 (at 2400 high)	3000 (at 1110 wide)	3.33
1562 (at 2338 high)	2922 (at 1250 wide)	3.65
1280 (at 2448 high)	3060 (at 1024 wide)	3.13

## CERTIFICATE No CF811

### Vetrotech Saint-Gobain International AG

#### Contraflam Lite 60 Glass in timber doors for periods of 60 minutes integrity

The glass shall be glazed within a previously fire tested or CERTIFIRE approved timber based doorset (which is covered appropriately by test or assessment evidence). The glass shall be set on non-combustible setting blocks to determine the correct edge cover.

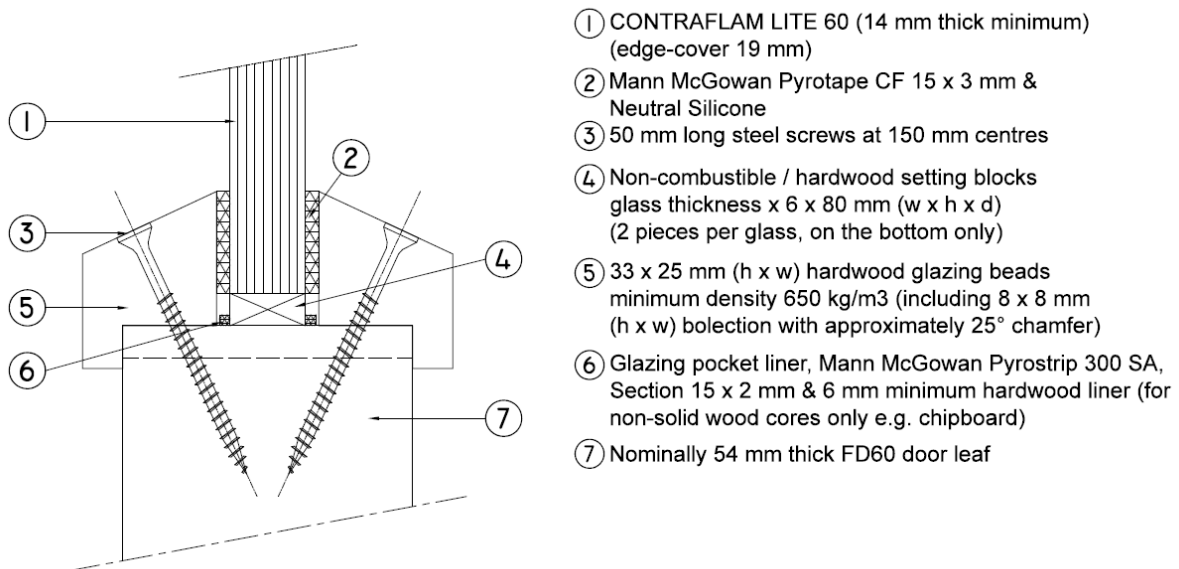

- ① CONTRAFLAM LITE 60 (14 mm thick minimum) (edge-cover 19 mm)
- ② Mann McGowan Pyrotape CF 15 x 3 mm & Neutral Silicone
- ③ 50 mm long steel screws at 150 mm centres
- ④ Non-combustible / hardwood setting blocks glass thickness x 6 x 80 mm (w x h x d) (2 pieces per glass, on the bottom only)
- ⑤ 33 x 25 mm (h x w) hardwood glazing beads minimum density 650 kg/m<sup>3</sup> (including 8 x 8 mm (h x w) bolection with approximately 25° chamfer)
- ⑥ Glazing pocket liner, Mann McGowan Pyrostrip 300 SA, Section 15 x 2 mm & 6 mm minimum hardwood liner (for non-solid wood cores only e.g. chipboard)
- ⑦ Nominally 54 mm thick FD60 door leaf

The doorset shall have test evidence or be CERTIFIRE approved for the inclusion of apertures of the proposed dimensions. This Certificate of Approval relates to the sizes of Contraflam Lite 60 glass shown in the table below, when used in conjunction with the above system:

Table 140 – Maximum Permitted Glass Dimensions		
Max. Width (mm)	Max. Height (mm)	Max. Area (m <sup>2</sup> )
529 (at 1586 high)	1776 (at 472 wide)	0.83

## CERTIFICATE No CF811

### Vetrotech Saint-Gobain International AG

#### Contraflam Lite 90 Glass in steel doors for periods of 90 minutes integrity

The glass shall be glazed within a previously fire tested or CERTIFIRE approved steel based doorset (which is covered appropriately by test or assessment evidence) using screw-fixed or clip-on retaining beads. The glass shall be glazed into the doorset as described below and set on non-combustible setting blocks to determine the correct edge cover.

① CONTRAFLAM LITE 90 (14 mm thick minimum)  
(edge-cover 15 mm minimum)

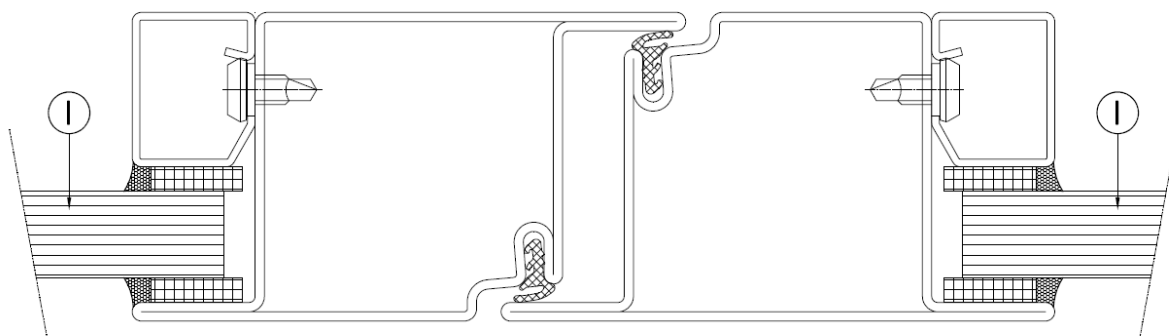

The doorset shall have test evidence or be CERTIFIRE approved for the inclusion of apertures of the proposed dimensions. This Certificate of Approval relates to the sizes of Contraflam Lite 90 glass shown in the table below, when used in conjunction with the above system:

Table 141 – Maximum Permitted Glass Dimensions		
Max. Width (mm)	Max. Height (mm)	Max. Area (m <sup>2</sup> )
1387 (at 2400 high)	3000 (at 1110 wide)	3.33
1562 (at 2338 high)	2922 (at 1250 wide)	3.65
1280 (at 2448 high)	3060 (at 1024 wide)	3.13

**Note: If applicable, a STADIP laminated glass used in the composition of the Contraflam unit is allowable, but on the fire side only.**

## CERTIFICATE No CF811

### Vetrotech Saint-Gobain International AG

#### Contraflam Lite 120 Glass in steel doors for periods of 120 minutes integrity

The glass shall be glazed within a previously fire tested or CERTIFIRE approved steel based doorset (which is covered appropriately by test or assessment evidence) using screw-fixed or clip-on retaining beads. The glass shall be glazed into the doorset as described below and set on non-combustible setting blocks to determine the correct edge cover.

① CONTRAFLAM LITE 120 (14 mm thick minimum)  
(edge-cover 15 mm minimum)

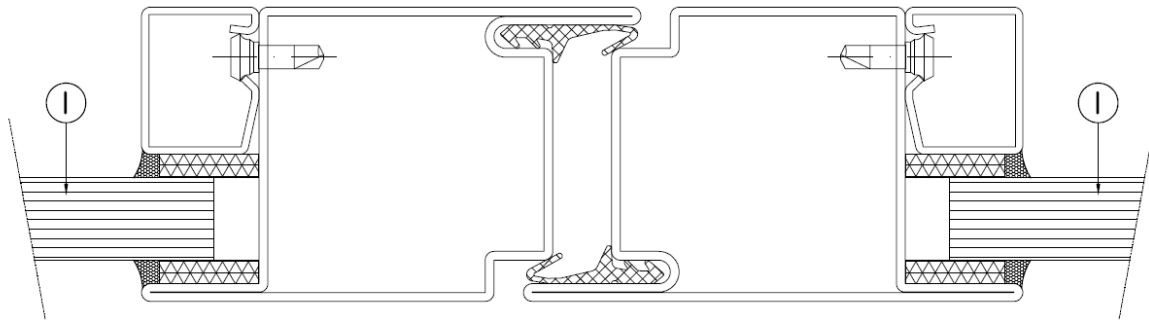

The doorset shall have test evidence or be CERTIFIRE approved for the inclusion of apertures of the proposed dimensions. This Certificate of Approval relates to the sizes of Contraflam Lite 120 glass shown in the table below, when used in conjunction with the above system:

Table 142 – Maximum Permitted Glass Dimensions		
Max. Width (mm)	Max. Height (mm)	Max. Area (m <sup>2</sup> )
1275 (at 2338 high)	2384 (at 1250 wide)	2.98
1126 (at 2448 high)	2693 (at 1024 wide)	2.75

**Note: If applicable, a STADIP laminated glass used in the composition of the Contraflam unit is allowable, but on the fire side only.**

## CERTIFICATE No CF811

### Vetrotech Saint-Gobain International AG

#### Contraflam 30 Glass in steel doors for periods of 30 minutes integrity and 30 minutes insulation

The glass shall be glazed within a previously fire tested or CERTIFIRE approved steel based doorset (which is covered appropriately by test or assessment evidence) using screw-fixed or clip-on retaining beads. The glass shall be glazed into the doorset as described below and set on non-combustible setting blocks to determine the correct edge cover.

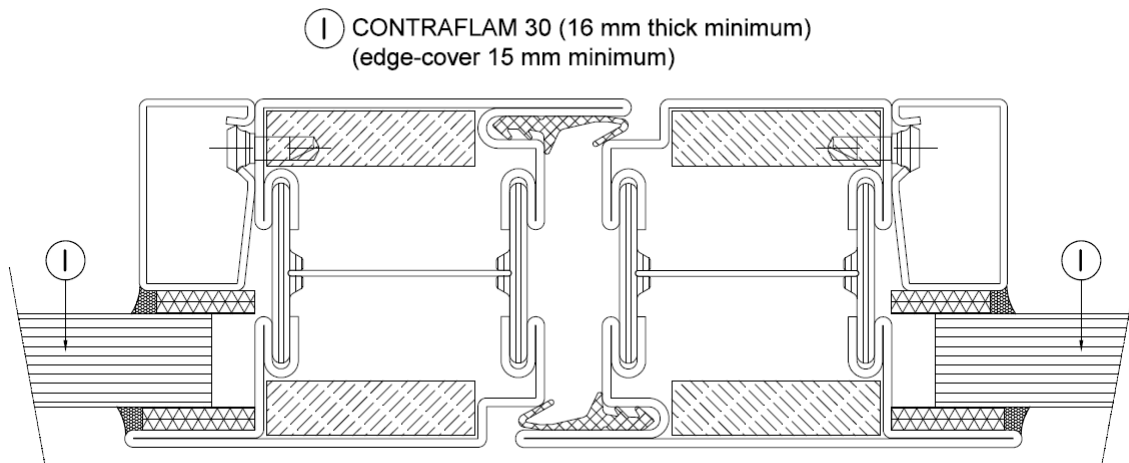

The doorset shall have test evidence or be CERTIFIRE approved for the inclusion of apertures of the proposed dimensions. This Certificate of Approval relates to the sizes of Contraflam 30 glass shown in the table below, when used in conjunction with the above system:

Table 143 – Maximum Permitted Glass Dimensions		
Max. Width (mm)	Max. Height (mm)	Max. Area (m <sup>2</sup> )
1620 (at 2573 high)	3216 (at 1296 wide)	4.16
1432 (at 2733 high)	3416 (at 1146 wide)	3.91

## CERTIFICATE No CF811

### Vetrotech Saint-Gobain International AG

#### Contraflam 30 Glass in steel doors for periods of 60 minutes integrity and 30 minutes insulation

The glass shall be glazed within a previously fire tested or CERTIFIRE approved steel based doorset (which is covered appropriately by test or assessment evidence) using screw-fixed or clip-on retaining beads. The glass shall be glazed into the doorset as described below and set on non-combustible setting blocks to determine the correct edge cover.

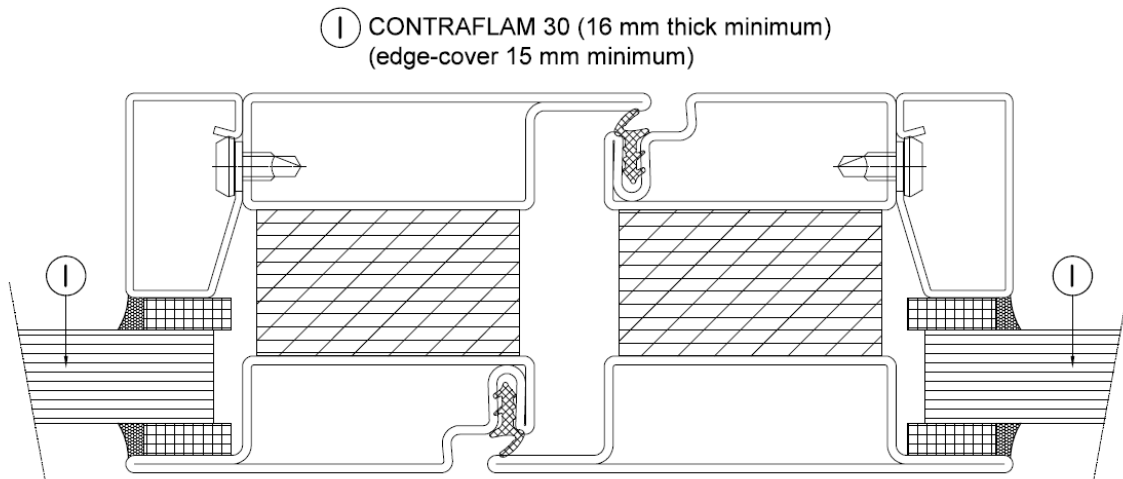

The doorset shall have test evidence or be CERTIFIRE approved for the inclusion of apertures of the proposed dimensions. This Certificate of Approval relates to the sizes of Contraflam 30 glass shown in the table below, when used in conjunction with the above system:

Table 144 – Maximum Permitted Glass Dimensions		
Max. Width (mm)	Max. Height (mm)	Max. Area (m2)
1471 (at 2387 high)	2697 (at 1302 wide)	3.51

## CERTIFICATE No CF811

### Vetrotech Saint-Gobain International AG

#### Contraflam 30 Glass in steel doors for periods of 90 minutes integrity and 30 minutes insulation

The glass shall be glazed within a previously fire tested or CERTIFIRE approved steel based doorset (which is covered appropriately by test or assessment evidence) using screw-fixed or clip-on retaining beads. The glass shall be glazed into the doorset as described below and set on non-combustible setting blocks to determine the correct edge cover.

① CONTRAFLAM 30 (16 mm thick minimum)  
(edge-cover 15 mm minimum)

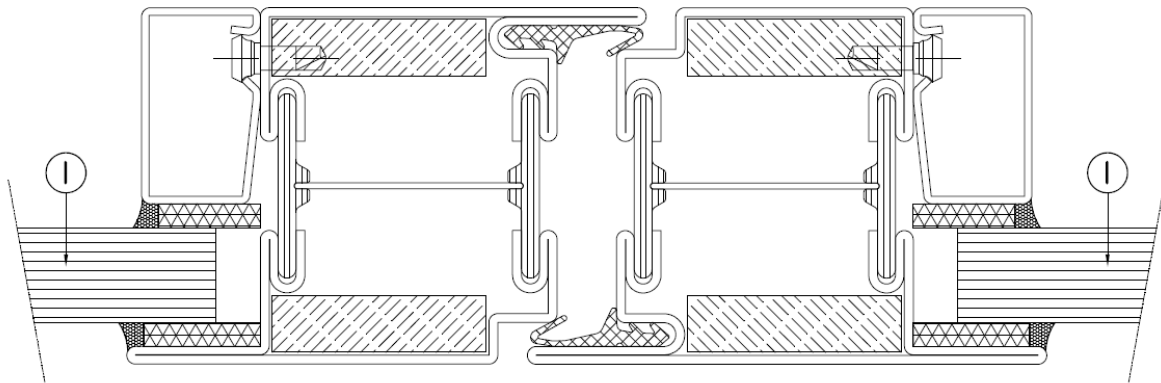

The doorset shall have test evidence or be CERTIFIRE approved for the inclusion of apertures of the proposed dimensions. This Certificate of Approval relates to the sizes of Contraflam 30 glass shown in the table below, when used in conjunction with the above system:

Table 145 – Maximum Permitted Glass Dimensions		
Max. Width (mm)	Max. Height (mm)	Max. Area (m <sup>2</sup> )
1137 (at 2135 high)	2626 (at 925 wide)	2.42

**Note:** If applicable, a STADIP laminated glass used in the composition of the Contraflam unit is allowable, but on the fire side only.

## CERTIFICATE No CF811

### Vetrotech Saint-Gobain International AG

#### Contraflam 30 Glass in steel doors for periods of 120 minutes integrity and 30 minutes insulation

The glass shall be glazed within a previously fire tested or CERTIFIRE approved steel based doorset (which is covered appropriately by test or assessment evidence) using screw-fixed or clip-on retaining beads. The glass shall be glazed into the doorset as described below and set on non-combustible setting blocks to determine the correct edge cover.

① CONTRAFLAM 30 (16 mm thick minimum)  
(edge-cover 15 mm minimum)

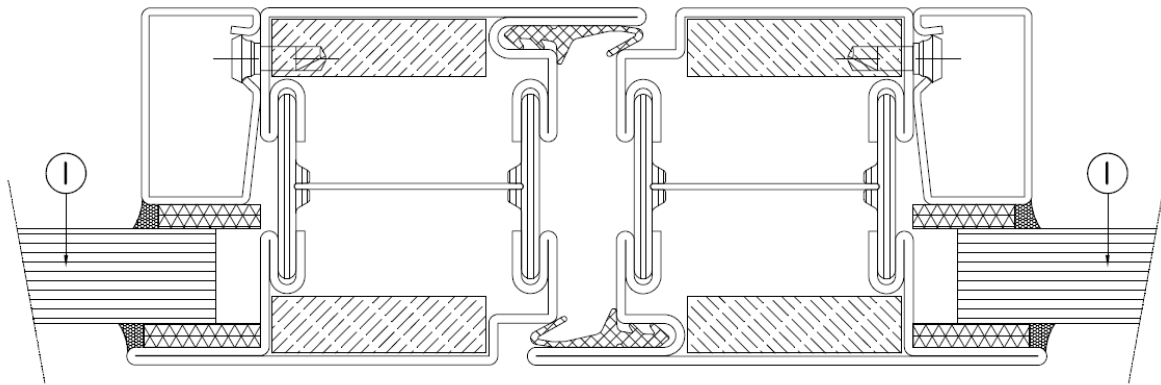

The doorset shall have test evidence or be CERTIFIRE approved for the inclusion of apertures of the proposed dimensions. This Certificate of Approval relates to the sizes of Contraflam 30 glass shown in the table below, when used in conjunction with the above system:

Table 146 – Maximum Permitted Glass Dimensions		
Max. Width (mm)	Max. Height (mm)	Max. Area (m <sup>2</sup> )
971 (at 2135 high)	2241 (at 925 wide)	2.07

**Note:** If applicable, a STADIP laminated glass used in the composition of the Contraflam unit is allowable, but on the fire side only.

## CERTIFICATE No CF811

### Vetrotech Saint-Gobain International AG

#### Contraflam 30 Glass in timber doors for periods of 30 minutes integrity and 30 minutes insulation

The glass shall be glazed within a previously fire tested or CERTIFIRE approved timber based doorset (which is covered appropriately by test or assessment evidence). The glass shall be set on non-combustible setting blocks to determine the correct edge cover.

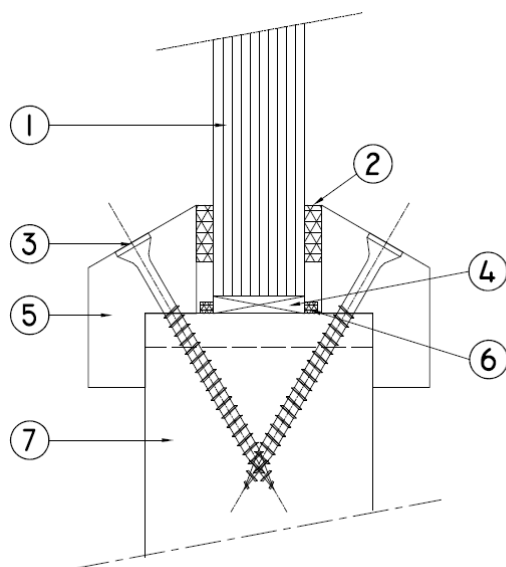

- ① CONTRAFLAM 30 (16 mm thick minimum) (edge-cover 16 mm)
- ② Mann McGowan Pyroglaze 30 Tape 10 x 3 mm
- ③ 50 mm long steel screws at 200 mm centres
- ④ Non-combustible / hardwood setting blocks glass thickness x 3 x 80 mm (w x h x d) (2 pieces per glass, on the bottom only)
- ⑤ 32 x 18.5 mm (h x w) hardwood glazing beads minimum density 650 kg/m<sup>3</sup> (including 13 x 10 mm (h x w) bolection with approximately 30° chamfer)
- ⑥ Glazing pocket liner, Mann McGowan Pyrostrip 300 SA, Section 15 x 2 mm & 6 mm minimum hardwood liner (for non-solid wood cores only e.g. chipboard)
- ⑦ Nominally 40 mm thick FD30 door leaf

The doorset shall have test evidence or be CERTIFIRE approved for the inclusion of apertures of the proposed dimensions. This Certificate of Approval relates to the sizes of Contraflam 30 glass shown in the table below, when used in conjunction with the above system:

Max. Width (mm)	Max. Height (mm)	Max. Area (m <sup>2</sup> )
1474 (at 2824 high)	3106 (at 1340 wide)	4.16

## CERTIFICATE No CF811

### Vetrotech Saint-Gobain International AG

#### Contraflam 30 Glass in Wicona Wicstyle 77FP aluminium doors for periods of 30 minutes integrity and 30 minutes insulation

The glass shall be glazed within a Wicona Wicstyle 77FP aluminium based doorset (which is covered appropriately by test or assessment evidence) using screw-fixed or clip-on retaining beads. The glass shall be glazed into the doorset as described below and set on non-combustible setting blocks to determine the correct edge cover.

① CONTRAFLAM 30 (16 mm thick minimum)  
(edge-cover 18 mm minimum)

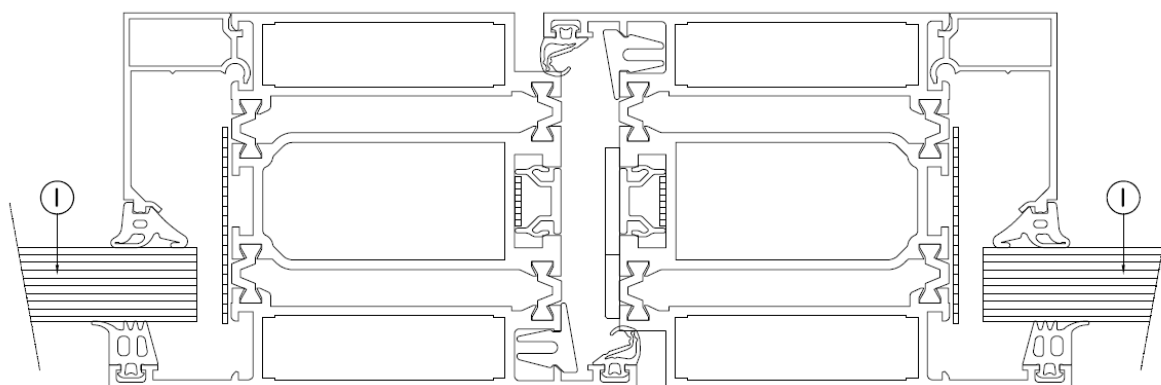

The doorset shall have test evidence or be CERTIFIRE approved for the inclusion of apertures of the proposed dimensions. This Certificate of Approval relates to the sizes of Contraflam 30 glass shown in the table below, when used in conjunction with the above system:

Table 148 – Maximum Permitted Glass Dimensions		
Max. Width (mm)	Max. Height (mm)	Max. Area (m <sup>2</sup> )
1474 (at 2824 high)	3106 (at 1340 wide)	4.16

## CERTIFICATE No CF811

### Vetrotech Saint-Gobain International AG

#### Contraflam 30 Glass in Alcoa Kawneer AA720 FR aluminium doors for periods of 30 minutes integrity and 30 minutes insulation

The glass shall be glazed within Alcoa Kawneer AA720 FR aluminium based doorset (which is covered appropriately by test or assessment evidence) using screw-fixed or clip-on retaining beads. The glass shall be glazed into the doorset as described below and set on non-combustible setting blocks to determine the correct edge cover.

① CONTRAFLAM 30 (16 mm thick minimum)  
(bead side edge-cover 17 mm minimum)

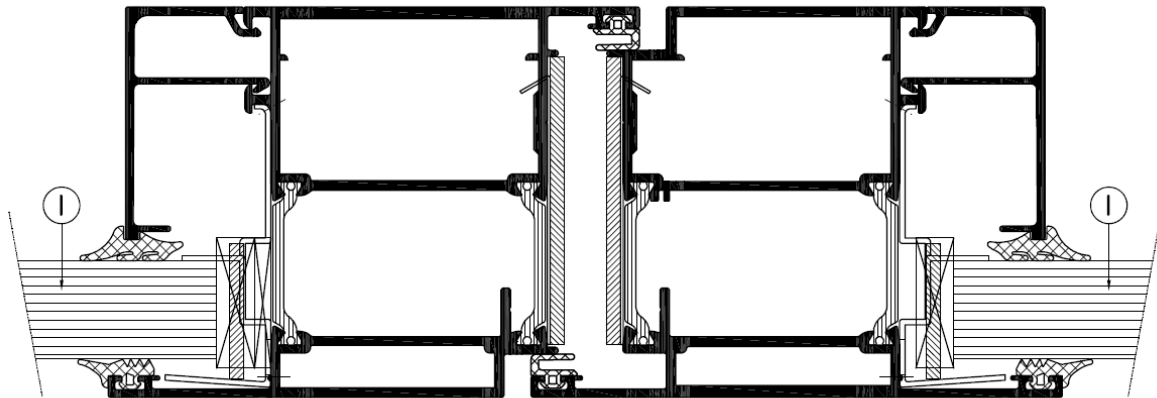

The doorset shall have test evidence or be CERTIFIRE approved for the inclusion of apertures of the proposed dimensions. This Certificate of Approval relates to the sizes of Contraflam 30 glass shown in the table below, when used in conjunction with the above system:

Max. Width (mm)	Max. Height (mm)	Max. Area (m2)
1492 (at 2444 high)	2932 (at 1244 wide)	3.64

## CERTIFICATE No CF811

### Vetrotech Saint-Gobain International AG

#### Contraflam 30 Glass in Schüco ADS 80 FR 30 aluminium doors for periods of 30 minutes integrity and 30 minutes insulation

The glass shall be glazed within Schüco ADS 80 FR 30 aluminium based doorset (which is covered appropriately by test or assessment evidence) using screw-fixed or clip-on retaining beads. The glass shall be glazed into the doorset as described below and set on non-combustible setting blocks to determine the correct edge cover.

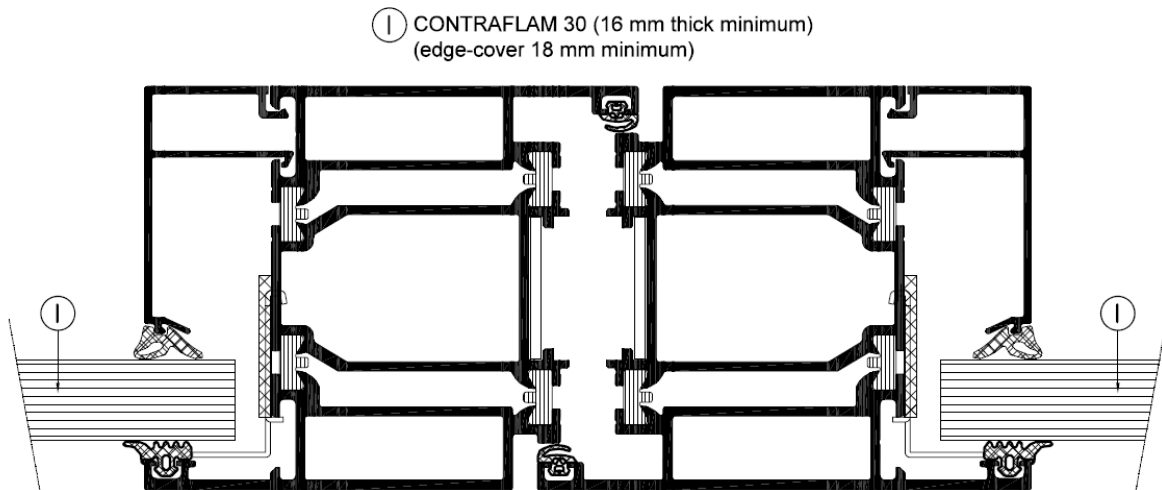

The doorset shall have test evidence or be CERTIFIRE approved for the inclusion of apertures of the proposed dimensions. This Certificate of Approval relates to the sizes of Contraflam 30 glass shown in the table below, when used in conjunction with the above system:

Table 150 – Maximum Permitted Glass Dimensions		
Max. Width (mm)	Max. Height (mm)	Max. Area (m <sup>2</sup> )
1446 (at 2875 high)	3248 (at 1280 wide)	4.15

## CERTIFICATE No CF811

### Vetrotech Saint-Gobain International AG

#### Contraflam 30 Climaplus Glass in steel doors for periods of 30 minutes integrity and 30 minutes insulation

The IGU shall be glazed within a previously fire tested or CERTIFIRE approved steel based doorset (which is covered appropriately by test or assessment evidence) using screw-fixed or clip-on retaining beads. The IGU shall be glazed into the doorset as described below and set on non-combustible setting blocks to determine the correct edge cover.

① CONTRAFLAM 30 CLIMAPLUS  
(edge-cover 15 mm minimum)

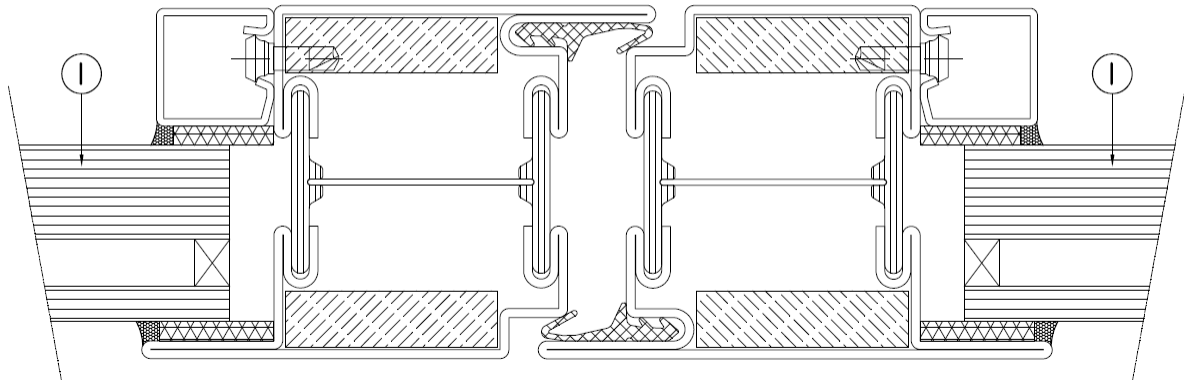

The doorset shall have test evidence or be CERTIFIRE approved for the inclusion of apertures of the proposed dimensions. This Certificate of Approval relates to the sizes of IGU's comprising at least one pane of Contraflam 30 glass shown in the table below, when used in conjunction with the above system:

Table 151 – Maximum Permitted Glass Dimensions		
Max. Width (mm)	Max. Height (mm)	Max. Area (m2)
1156 (at 2135 high)	2668 (at 925 wide)	2.46

## CERTIFICATE No CF811

### Vetrotech Saint-Gobain International AG

#### Contraflam 30 Climaplus Glass in steel doors for periods of 90 minutes integrity and 30 minutes insulation

The IGU shall be glazed within a previously fire tested or CERTIFIRE approved steel based doorset (which is covered appropriately by test or assessment evidence) using screw-fixed or clip-on retaining beads. The IGU shall be glazed into the doorset as described below and set on non-combustible setting blocks to determine the correct edge cover.

① CONTRAFLAM 30 CLIMAPLUS  
(edge-cover 15 mm minimum)

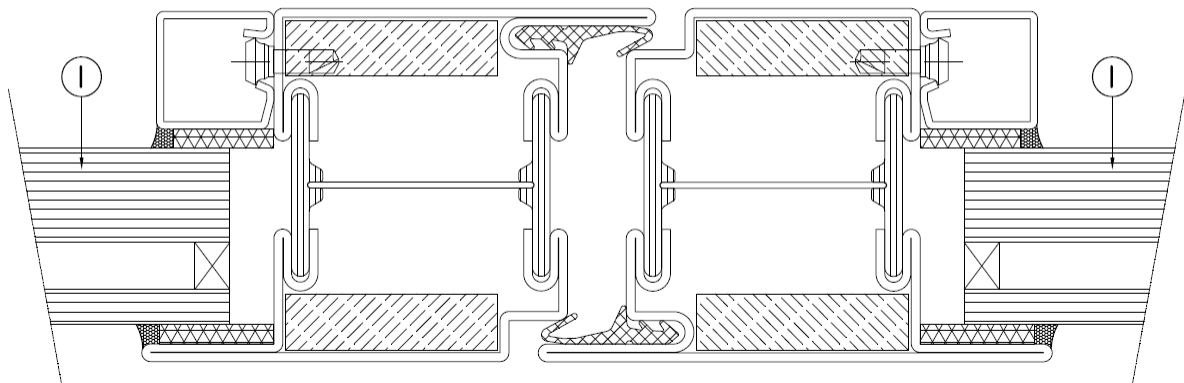

The doorset shall have test evidence or be CERTIFIRE approved for the inclusion of apertures of the proposed dimensions. This Certificate of Approval relates to the sizes of IGU's comprising at least one pane of Contraflam 30 glass shown in the table below, when used in conjunction with the above system:

Table 152 – Maximum Permitted Glass Dimensions		
Max. Width (mm)	Max. Height (mm)	Max. Area (m2)
1137 (at 2135 high)	2626 (at 925 wide)	2.42

**Note: If applicable, a STADIP laminated counterpane or STADIP laminated glass used in the composition of the Contraflam unit is allowable, but on the fire side only.**

## CERTIFICATE No CF811

### Vetrotech Saint-Gobain International AG

#### Contraflam 30 Climaplus Glass in steel doors for periods of 120 minutes integrity and 30 minutes insulation

The IGU shall be glazed within a previously fire tested or CERTIFIRE approved steel based doorset (which is covered appropriately by test or assessment evidence) using screw-fixed or clip-on retaining beads. The IGU shall be glazed into the doorset as described below and set on non-combustible setting blocks to determine the correct edge cover.

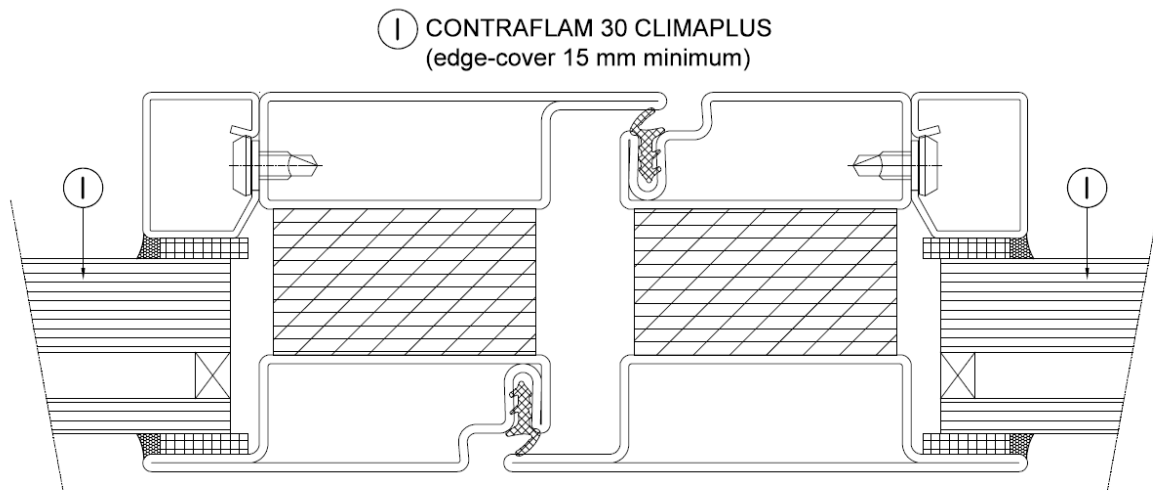

The doorset shall have test evidence or be CERTIFIRE approved for the inclusion of apertures of the proposed dimensions. This Certificate of Approval relates to the sizes of IGU's comprising at least one pane of Contraflam 30 glass shown in the table below, when used in conjunction with the above system:

Table 153 – Maximum Permitted Glass Dimensions		
Max. Width (mm)	Max. Height (mm)	Max. Area (m2)
971 (at 2135 high)	2241 (at 925 wide)	2.07

**Note:** If applicable, a STADIP laminated counterpane or STADIP laminated glass used in the composition of the Contraflam unit is allowable, but on the fire side only.

## CERTIFICATE No CF811

### Vetrotech Saint-Gobain International AG

#### Contraflam 30-2 Glass in steel doors for periods of 30 minutes integrity and 30 minutes insulation

The glass shall be glazed within a previously fire tested or CERTIFIRE approved steel based doorset (which is covered appropriately by test or assessment evidence) using screw-fixed or clip-on retaining beads. The glass shall be glazed into the doorset as described below and set on non-combustible setting blocks to determine the correct edge cover.

① CONTRAFLAM 30-2 (20 mm thick minimum)  
(edge-cover 15 mm minimum)

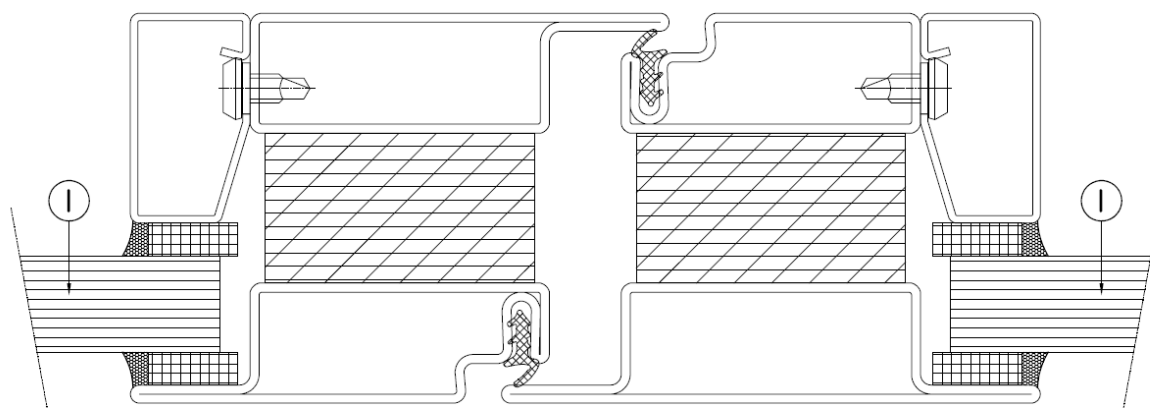

The doorset shall have test evidence or be CERTIFIRE approved for the inclusion of apertures of the proposed dimensions. This Certificate of Approval relates to the sizes of Contraflam 30-2 glass shown in the table below, when used in conjunction with the above system:

Table 154 – Maximum Permitted Glass Dimensions		
Max. Width (mm)	Max. Height (mm)	Max. Area (m <sup>2</sup> )
1600 (at 2840 high)	3550 (at 1280 wide)	4.54

## CERTIFICATE No CF811

### Vetrotech Saint-Gobain International AG

#### Contraflam 30-2 Glass in timber doors for periods of 30 minutes integrity and 30 minutes insulation

The glass shall be glazed within a previously fire tested or CERTIFIRE approved timber based doorset (which is covered appropriately by test or assessment evidence). The glass shall be set on non-combustible setting blocks to determine the correct edge cover.

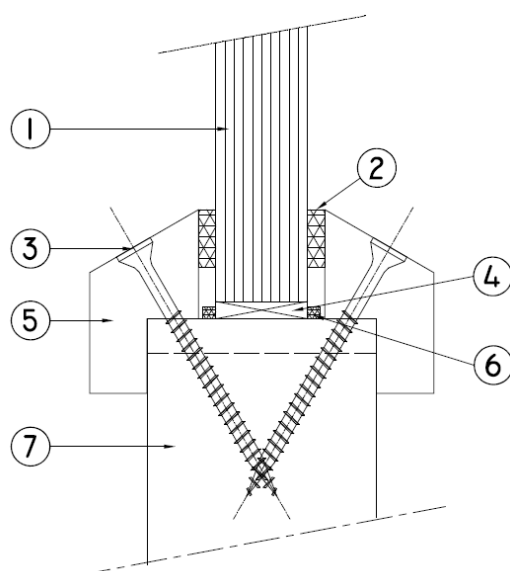

- ① CONTRAFLAM 30-2 (20 mm thick minimum) (edge-cover 16 mm)
- ② Mann McGowan Pyroglaze 30 Tape 10 x 3 mm
- ③ 50 mm long steel screws at 200 mm centres
- ④ Non-combustible / hardwood setting blocks glass thickness x 3 x 80 mm (w x h x d) (2 pieces per glass, on the bottom only)
- ⑤ 32 x 18.5 mm (h x w) hardwood glazing beads minimum density 650 kg/m<sup>3</sup> (including 13 x 10 mm (h x w) bolection with approximately 30° chamfer)
- ⑥ Glazing pocket liner, Mann McGowan Pyrostrip 300 SA, Section 15 x 2 mm & 6 mm minimum hardwood liner (for non-solid wood cores only e.g. chipboard)
- ⑦ Nominally 40 mm thick FD30 door leaf

The doorset shall have test evidence or be CERTIFIRE approved for the inclusion of apertures of the proposed dimensions. This Certificate of Approval relates to the sizes of Contraflam 30-2 glass shown in the table below, when used in conjunction with the above system:

Table 155 – Maximum Permitted Glass Dimensions		
Max. Width (mm)	Max. Height (mm)	Max. Area (m <sup>2</sup> )
1600 (at 2840 high)	3550 (at 1280 wide)	4.54

## CERTIFICATE No CF811

### Vetrotech Saint-Gobain International AG

#### Contraflam 30-2 Glass in Schüco ADS 80 FR 30 aluminium doors for periods of 30 minutes integrity and 30 minutes insulation

The glass shall be glazed within Schüco ADS 80 FR 30 aluminium based doorset (which is covered appropriately by test or assessment evidence) using screw-fixed or clip-on retaining beads. The glass shall be glazed into the doorset as described below and set on non-combustible setting blocks to determine the correct edge cover.

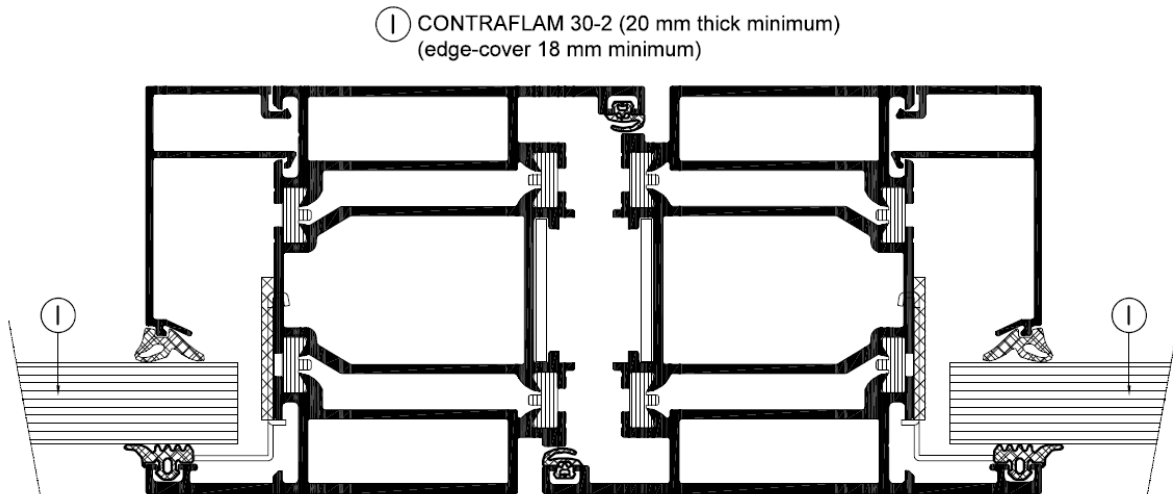

The doorset shall have test evidence or be CERTIFIRE approved for the inclusion of apertures of the proposed dimensions. This Certificate of Approval relates to the sizes of Contraflam 30-2 glass shown in the table below, when used in conjunction with the above system:

Table 156 – Maximum Permitted Glass Dimensions		
Max. Width (mm)	Max. Height (mm)	Max. Area (m <sup>2</sup> )
1600 (at 2840 high)	3550 (at 1280 wide)	4.54

## CERTIFICATE No CF811

### Vetrotech Saint-Gobain International AG

#### Contraflam 60-3 Glass in steel doors for periods of 60 minutes integrity and 60 minutes insulation

The glass shall be glazed within a previously fire tested or CERTIFIRE approved steel based doorset (which is covered appropriately by test or assessment evidence) using screw-fixed or clip-on retaining beads. The glass shall be glazed into the doorset as described below and set on non-combustible setting blocks to determine the correct edge cover.

① CONTRAFLAM 60-3 (27 mm thick minimum)  
(edge-cover 15 mm minimum)

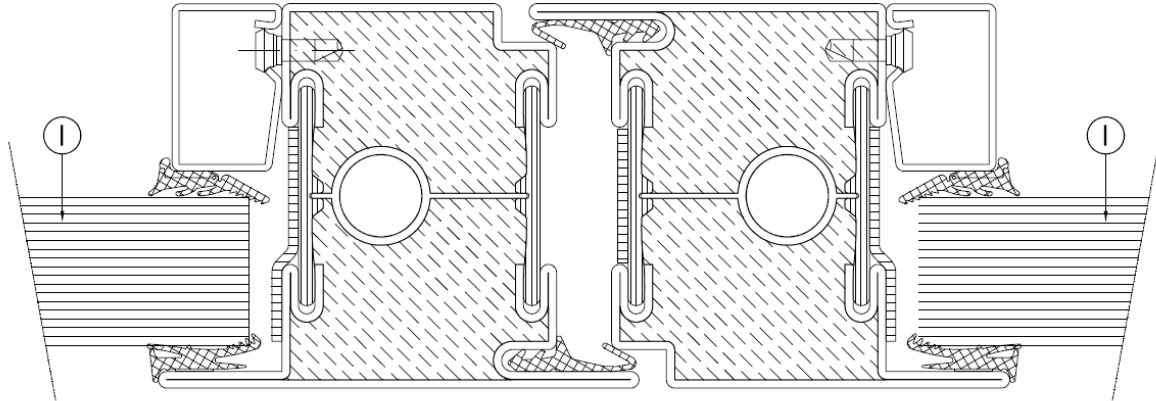

The doorset shall have test evidence or be CERTIFIRE approved for the inclusion of apertures of the proposed dimensions. This Certificate of Approval relates to the sizes of Contraflam 60-3 glass shown in the table below, when used in conjunction with the above system:

Table 157 – Maximum Permitted Glass Dimensions		
Max. Width (mm)	Max. Height (mm)	Max. Area (m2)
1382 (at 2875 high)	3105 (at 1280 wide)	3.97
1611 (at 2390 high)	2939 (at 1310 wide)	3.85

## CERTIFICATE No CF811

### Vetrotech Saint-Gobain International AG

#### Contraflam 60-3 Glass in timber doors for periods of 60 minutes integrity and 60 minutes insulation

The glass shall be glazed within a previously fire tested or CERTIFIRE approved timber based doorset (which is covered appropriately by test or assessment evidence). The glass shall be set on non-combustible setting blocks to determine the correct edge cover.

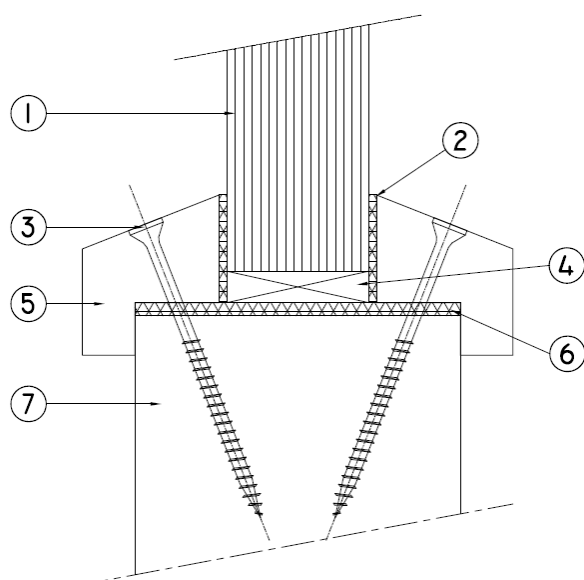

- ① CONTRAFLAM 60-3 (27 mm thick minimum) (edge-cover 15 mm)
- ② Sealmaster Fireglaze tape 20 x 2.5 mm
- ③ No 8 x 3" long steel screws at 150 mm centres (22° to glass)
- ④ Non-combustible / hardwood setting blocks glass thickness x 6 x 80 mm (w x h x d) (2 pieces per glass, on the bottom only)
- ⑤ 30.5 x 26.3 mm (h x w) hardwood glazing beads minimum density 665 kg/m<sup>3</sup> (including 10 x 10 mm (h x w) bolection with 20° chamfer)
- ⑥ Door liner, Sealmaster Fireglaze tape 62 x 2.5 mm
- ⑦ Nominally 62 mm thick FD60 door leaf

The doorset shall have test evidence or be CERTIFIRE approved for the inclusion of apertures of the proposed dimensions. This Certificate of Approval relates to the sizes of Contraflam 60-3 glass shown in the table below, when used in conjunction with the above system:

Table 158 – Maximum Permitted Glass Dimensions		
Max. Width (mm)	Max. Height (mm)	Max. Area (m <sup>2</sup> )
1382 (at 2875 high)	3105 (at 1280 wide)	3.97

## CERTIFICATE No CF811

### Vetrotech Saint-Gobain International AG

#### Contraflam 60-3 Glass in Schüco ADS 80 FR 60 aluminium doors for periods of 60 minutes integrity and 60 minutes insulation

The glass shall be glazed within Schüco ADS 80 FR 60 aluminium based doorset (which is covered appropriately by test or assessment evidence) using screw-fixed or clip-on retaining beads. The glass shall be glazed into the doorset as described below and set on non-combustible setting blocks to determine the correct edge cover.

① CONTRAFLAM 60-3 (27 mm thick minimum)  
(edge-cover 18 mm minimum)

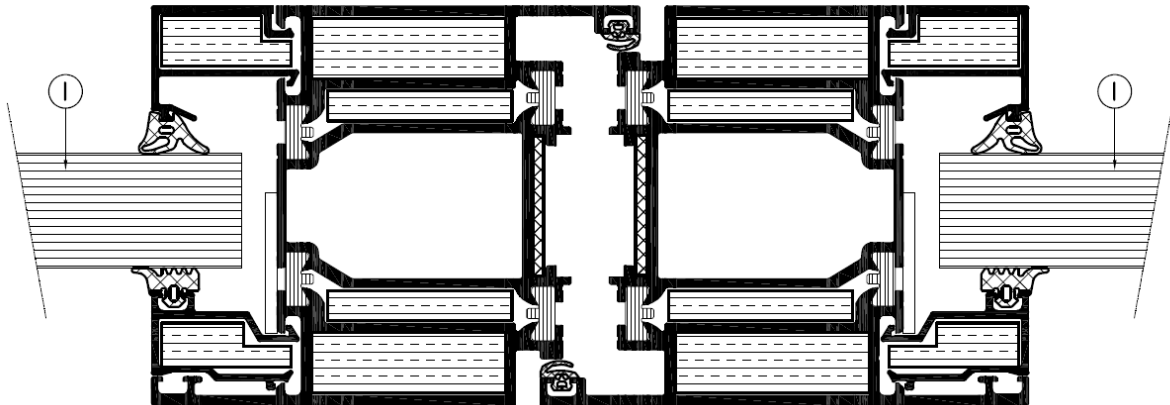

The doorset shall have test evidence or be CERTIFIRE approved for the inclusion of apertures of the proposed dimensions. This Certificate of Approval relates to the sizes of Contraflam 60-3 glass shown in the table below, when used in conjunction with the above system:

Table 159 – Maximum Permitted Glass Dimensions		
Max. Width (mm)	Max. Height (mm)	Max. Area (m <sup>2</sup> )
1382 (at 2875 high)	3105 (at 1280 wide)	3.97

## CERTIFICATE No CF811

### Vetrotech Saint-Gobain International AG

#### Contraflam 60-3 Climaplust Glass in steel doors for periods of 60 minutes integrity and 60 minutes insulation

The IGU shall be glazed within a previously fire tested or CERTIFIRE approved steel based doorset (which is covered appropriately by test or assessment evidence) using screw-fixed or clip-on retaining beads. The IGU shall be glazed into the doorset as described below and set on non-combustible setting blocks to determine the correct edge cover.

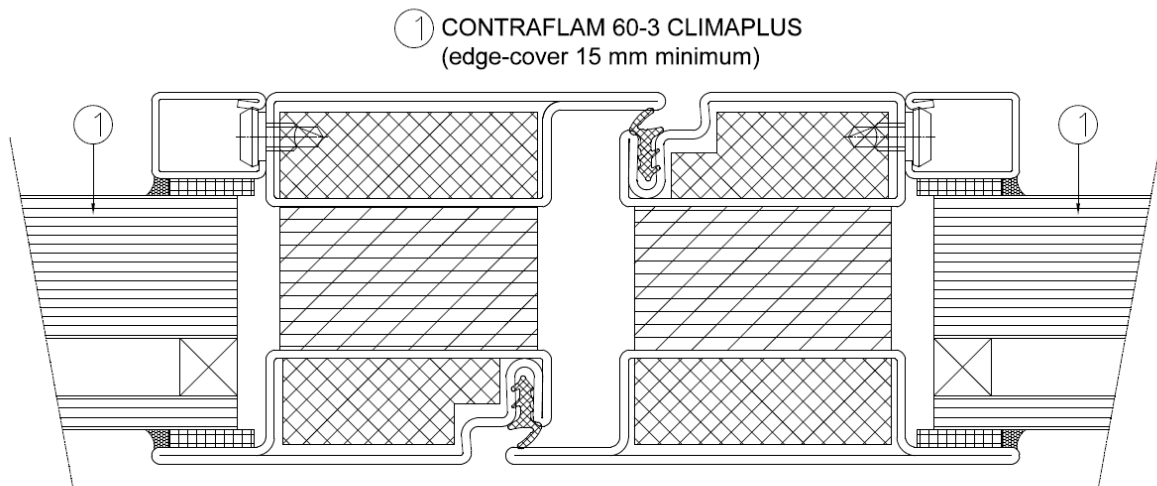

The doorset shall have test evidence or be CERTIFIRE approved for the inclusion of apertures of the proposed dimensions. This Certificate of Approval relates to the sizes of IGU's comprising at least one pane of Contraflam 60-3 glass shown in the table below, when used in conjunction with the above system:

Table 160 – Maximum Permitted Glass Dimensions		
Max. Width (mm)	Max. Height (mm)	Max. Area (m2)
1519 (at 2390 high)	2772 (at 1310 wide)	3.63

## CERTIFICATE No CF811

### Vetrotech Saint-Gobain International AG

#### Contraflam 90-4 Glass in steel doors for periods of 90 minutes integrity and 90 minutes insulation

The glass shall be glazed within a previously fire tested or CERTIFIRE approved steel based doorset (which is covered appropriately by test or assessment evidence) using screw-fixed or clip-on retaining beads. The glass shall be glazed into the doorset as described below and set on non-combustible setting blocks to determine the correct edge cover.

① CONTRAFLAM 90-4 (40 mm thick minimum)  
(edge-cover 15 mm minimum)

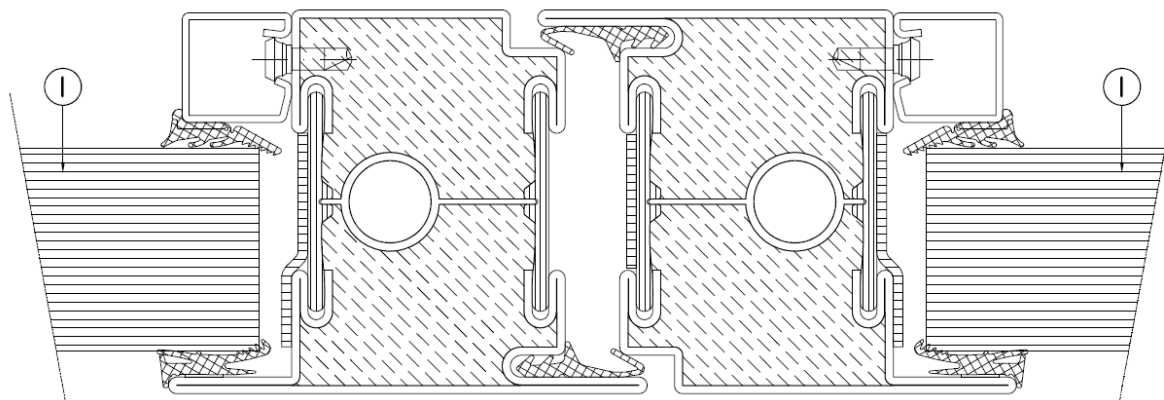

The doorset shall have test evidence or be CERTIFIRE approved for the inclusion of apertures of the proposed dimensions. This Certificate of Approval relates to the sizes of Contraflam 90-4 glass shown in the table below, when used in conjunction with the above system:

Table 161 – Maximum Permitted Glass Dimensions		
Max. Width (mm)	Max. Height (mm)	Max. Area (m2)
1364 (at 2500 high)	3100 (at 1100 wide)	3.41
1428 (at 2760 high)	2898 (at 1360 wide)	3.94
1536 (at 2360 high)	2666 (at 1360 wide)	3.62

## CERTIFICATE No CF811

### Vetrotech Saint-Gobain International AG

#### Contraflam 90-4 Glass in Schüco Firestop T90/F90 aluminium doors for periods of 90 minutes integrity and 90 minutes insulation

The glass shall be glazed within Schüco Firestop T90/F90 aluminium based doorset (which is covered appropriately by test or assessment evidence) using screw-fixed or clip-on retaining beads. The glass shall be glazed into the doorset as described below and set on non-combustible setting blocks to determine the correct edge cover.

① CONTRAFLAM 90-4 (40 mm thick minimum)  
(edge-cover 17 mm minimum)

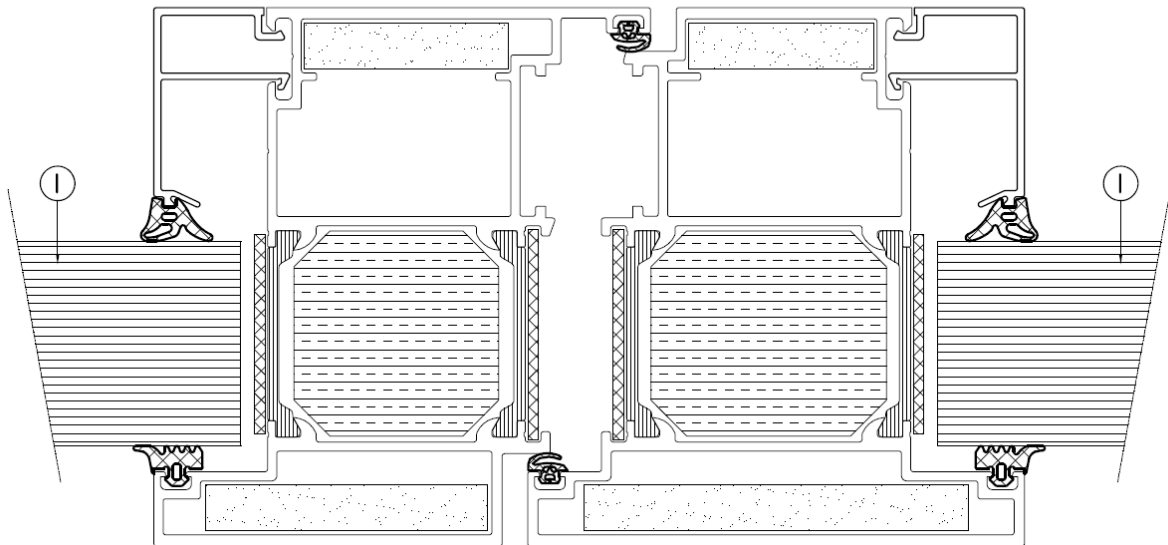

The doorset shall have test evidence or be CERTIFIRE approved for the inclusion of apertures of the proposed dimensions. This Certificate of Approval relates to the sizes of Contraflam 90-4 glass shown in the table below, when used in conjunction with the above system:

Max. Width (mm)	Max. Height (mm)	Max. Area (m <sup>2</sup> )
1224 (at 2304 high)	2350 (at 1200 wide)	2.82

## CERTIFICATE No CF811

### Vetrotech Saint-Gobain International AG

#### Contraflam 90-4 Glass in Aluprof MB-78EI aluminium doors for periods of 90 minutes integrity and 90 minutes insulation

The glass shall be glazed within Aluprof MB-78EI aluminium based doorset (which is covered appropriately by test or assessment evidence) using screw-fixed or clip-on retaining beads. The glass shall be glazed into the doorset as described below and set on non-combustible setting blocks to determine the correct edge cover.

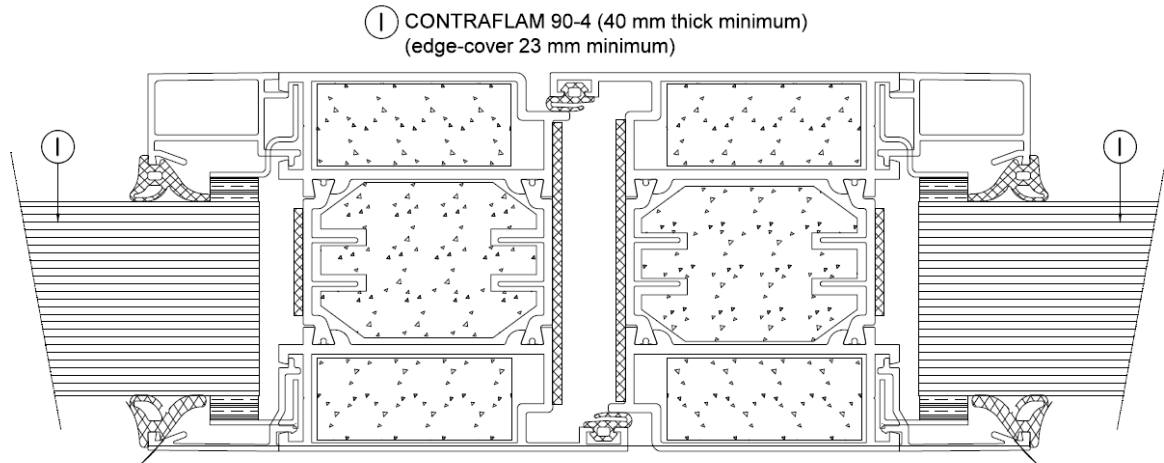

The doorset shall have test evidence or be CERTIFIRE approved for the inclusion of apertures of the proposed dimensions. This Certificate of Approval relates to the sizes of Contraflam 90-4 glass shown in the table below, when used in conjunction with the above system:

Table 163 – Maximum Permitted Glass Dimensions		
Max. Width (mm)	Max. Height (mm)	Max. Area (m2)
1348 (at 2360 high)	2525 (at 1260 wide)	3.18

## CERTIFICATE No CF811

### Vetrotech Saint-Gobain International AG

#### Contraflam 120-6 Glass in Renown Engineering steel doors for periods of 120 minutes integrity and 120 minutes insulation

The glass shall be glazed within a previously fire tested or CERTIFIRE approved steel based doorset (which is covered appropriately by test or assessment evidence) using screw-fixed or clip-on retaining beads. The glass shall be glazed into the doorset as described below and set on non-combustible setting blocks to determine the correct edge cover.

① CONTRAFLAM 120-6 (60 mm thick minimum)  
(edge-cover 14 mm minimum)

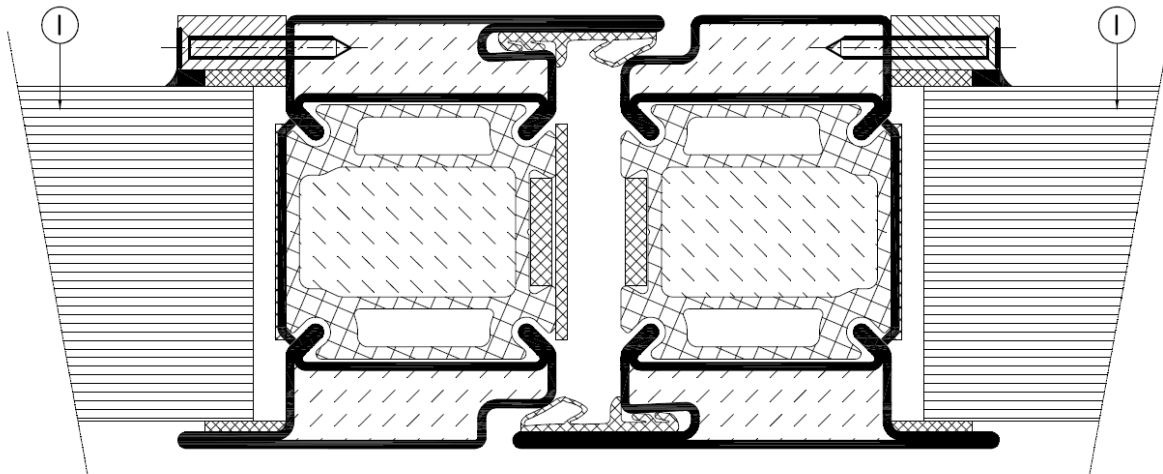

The doorset shall have test evidence or be CERTIFIRE approved for the inclusion of apertures of the proposed dimensions. This Certificate of Approval relates to the sizes of Contraflam 120-6 glass shown in the table below, when used in conjunction with the above system:

Table 164 – Maximum Permitted Glass Dimensions		
Max. Width (mm)	Max. Height (mm)	Max. Area (m2)
922	2307	2.12